









Informazioni  
**IMPORTANTI**  
Very important  
**INFORMATION**

Condizioni  
generali di vendita  
General sales  
conditions

## Sommario - Summary

 <p>MyWay Bluetooth Pag. 210</p>	 <p>DALI 2 PUSH Protocol DALI 2 EMER Pag. 215 - 217</p>	 <p>Syros R-C-S recessed, ceiling, suspended Pag. 218</p>	 <p>Patmos Lens R-C-S recessed, ceiling, suspended Pag. 225</p>
---	--	---	--

 <p>Egeo R-C-S recessed, ceiling, suspended Pag. 229</p>	 <p>Zante R-C-S recessed, ceiling, suspended Pag. 232</p>	 <p>Milo backlit R-C-S recessed, ceiling Pag. 236</p>	 <p>Itaca R-C-S recessed, ceiling, suspended Pag. 240</p>
---	--	---	--

 <p>Itaca doghe speciali recessed, ceiling Pag. 246</p>	 <p>Mercedes R-C-S recessed, ceiling, suspended Pag. 248</p>	 <p>Mercedes Floor up &amp; down floor Pag. 256</p>	 <p>Zante Floor up &amp; down floor Pag. 258</p>
---	--	--	--

 <p>LED Bronzo floor Up &amp; Down floor Pag. 260</p>	 <p>Giorgia floor Pag. 262</p>	 <p>Unica S-C ceiling, suspended Pag. 264</p>	 <p>Syros Slim S-C ceiling, suspended Pag. 266</p>
--	---	---	---

## Sommario - Summary



 <p>Sky system S-C ceiling, suspended Pag. 275</p>	 <p>Sky box W wall Pag. 286</p>	 <p>Infinity ceiling, suspended Pag. 288</p>	 <p>Aria Ultra-thin recessed Pag. 296</p>
---	--	---	--



 <p>Ferma recessed Pag. 298</p>	 <p>Cielo QR recessed Pag. 300</p>	 <p>Cielo RR - Cielo 3RR recessed Pag. 302 - 303</p>	 <p>Intrepido 3 CCT recessed Pag. 304</p>
--	---	---	--

 <p>Beautylight recessed Pag. 306</p>	 <p>Gloria RR recessed Pag. 308</p>	 <p>Gloria QR recessed Pag. 310</p>	 <p>Gessi incasso recessed Pag. 312</p>
---	---	---	---

 <p>Imperceptible recessed Pag. 316</p>	 <p>Aqua recessed Pag. 324</p>	 <p>Life 150 - Life recessed Pag. 329</p>	 <p>Marian recessed Pag. 335</p>
--	---	--	---

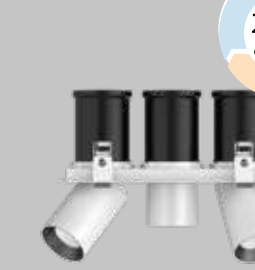
## Sommario - Summary

 <p>Equal Family recessed, ceiling, wall, Pag. 336</p>	 <p>Ardito recessed Pag. 342</p>	 <p>Bazar Serie recessed Pag. 344</p>	 <p>Regina recessed recessed Pag. 346</p>
---	---	--	--

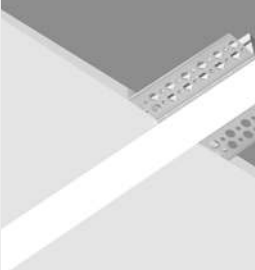
 <p>Otto recessed Pag. 348</p>	 <p>Nove recessed Pag. 350</p>	 <p>Trim R Opal recessed Pag. 353</p>	 <p>Trim 50 R Opal recessed Pag. 355</p>
---	---	--	---











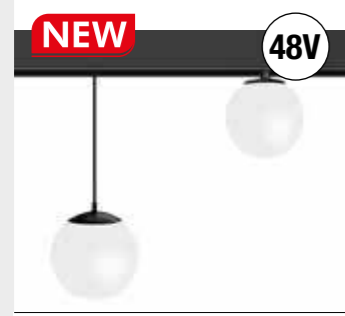



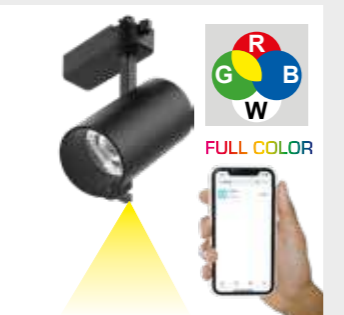

 <p>Syros Slim system R recessed Pag. 356</p>	 <p>Infinity R recessed Pag. 359</p>	 <p>Creta R 600-1200 recessed Pag. 360</p>	 <p>Rodi R-S recessed, suspended Pag. 363</p>
---	--	--	---

 <p>Picasso 48V Track light Pag. 364</p>	 <p>Mirò 48V Track light Pag. 366</p>	 <p>Fontana - Botero Track light Pag. 368-370</p>	 <p>Gilbert &amp; George - Rotella Track light Pag. 372</p>
---	--	--	--

















Informazioni  
**IMPORTANTI**  
Very important  
**INFORMATION**

Condizioni  
generali di vendita  
General sales  
conditions















**Sommario - Summary**

 <b>NEW</b> 48V Burri Track light, suspended Pag. 373	 48V Track light 48V ceiling, suspended, recessed Pag. 374 - 387	 48V LED Estensione - cable light suspended, ceiling, wall Pag. 388-393	 Quadro Trifase track light Pag. 394
 <b>NEW</b> Museum Track light Pag. 396	 Primadonna trifase Track light Pag. 399	 Primadonna trifase RGBW Track light Pag. 401	 3 CCT COLOUR CHANGING Regina 3 CCT trifase Track light Pag. 402
 Primavera trifase track light Pag. 404	 Shop windows Trifase track light Pag. 406	 <b>NEW</b> Infinity trifase Track light Pag. 408	 3S Sky system trifase Track light Pag. 412
 Control systems for three-phase track Pag. 416	 Sirio - Venere Track light Pag. 418	 3 circuit Track light ceiling, suspended, recessed Pag. 420	 <b>NEW</b> Shop Windows C-W ceiling, wall Pag. 424

**Sommario - Summary**

 Audace C-W-R ceiling, wall, recessed Pag. 426	 Primavera C-W-R ceiling, wall, recessed Pag. 428	 Primadonna C-W ceiling, wall Pag. 430	 IP 44 Camilla ceiling Pag. 432
 IP 54 Dolcetondo ceiling Pag. 433	 Pop W wall Pag. 436	 Lineasu W wall Pag. 440	 Gessi applique wall Pag. 442
 IP 20 2 in 1 2 CCT COLOUR CHANGING Huitre wall Pag. 444	 Rouget wall Pag. 445	 3 in 1 3 CCT COLOUR CHANGING Rhombe wall, ceiling, suspended Pag. 446	 IP 20 3 in 1 3 CCT COLOUR CHANGING Coquille wall Pag. 448
 3 in 1 3 CCT COLOUR CHANGING Sovraspecchio wall Pag. 450	 3 in 1 3 CCT COLOUR CHANGING Primadonna S suspended Pag. 452	 Imperceptible S suspended Pag. 454	 Zante Top up & down suspended Pag. 458

**Sommario - Summary**

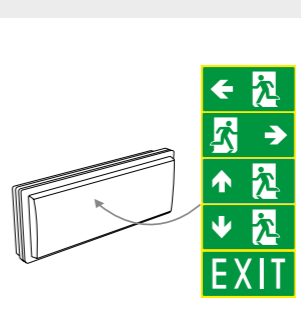
 IP 43 Luxxi suspended Pag. 460	 IP 67 Strisce Flex and aluminium heat sink Pag. 462	 IP 67 Neon Flex and aluminium heat sink Pag. 471	 IP 65 LED Agile Silicone ceiling, wall, floor, recessed Pag. 478
 Driver per Strisce Flex 12-24-48Vdc Pag. 480	 3 in 1 3 CCT COLOUR CHANGING LED Linee di Luce C-W ceiling, wall Pag. 490	 3 CCT COLOUR CHANGING LED Classica ceiling Pag. 492	 DALI 2 Control panel / Router Dali Emergency LED system Pag. 494
 DALI 2 AUTOTEST Osiride Emergenza Dali Emergency LED system Pag. 500	 DALI 2 AUTOTEST Osiride Segnalazione Dali Emergency LED system Pag. 502	 DALI 2 AUTOTEST LED SPOT EMER SE 3H Dali Emergency LED system Pag. 504	 AUTOTEST Raja W-C-R Emergency LED system Pag. 508
 BASIC series Orione Emergency LED Pag. 510	 BASIC series AUTOTEST Sirio Emergency LED system Pag. 514	 BASIC series AUTOTEST Venere Emergency LED system Pag. 516	 Sirio - Venere Accessories Pag. 518

**Sommario - Summary**

 AUTOTEST LED SPOT EMER SE 3H flush mounting Box503 Pag. 522	 IP 54 Cuculo 503 recessed, wall Pag. 524	 LED Keymer flush mounting Box503 Pag. 526
---	--	--

 Lampade medicali Pag. 528
---



# MyWay Bluetooth<sup>®</sup> 5.0 SIG MESH

## Guida al sistema di gestione della luce *Light management system guide*

- **non necessita di sistemisti e di costi aggiuntivi di programmazione**  
*it does not require system engineers and additional programming costs*
- **permette attraverso la gestione intelligente della luce un risparmio del 70%**  
*intelligent light management enables a saving of*
- **azzerata la manutenzione con comunicazione costante via mail dello stato dell'impianto**  
*eliminates maintenance with constant communication of the system status via email*

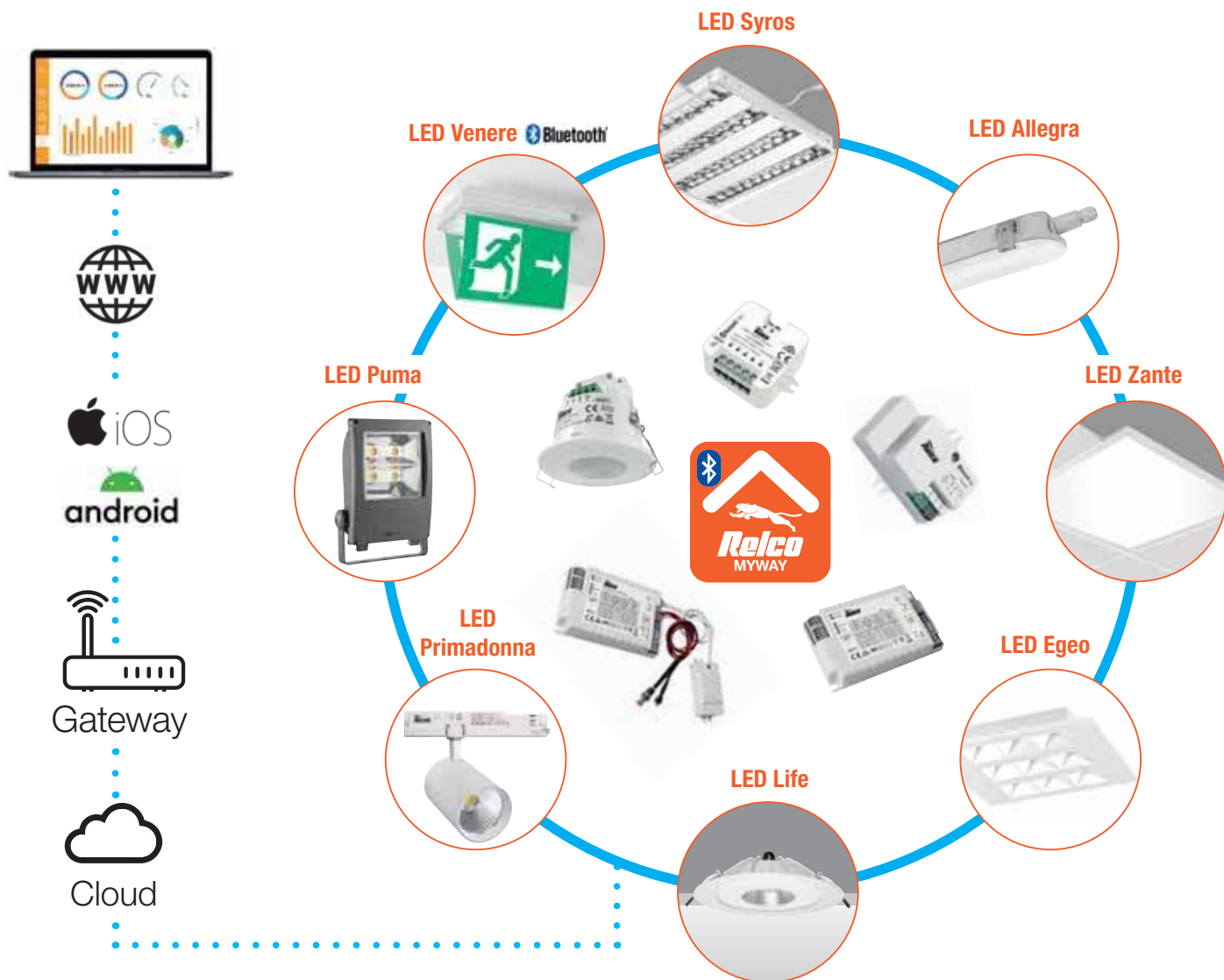

**Varialuce  
Dimmer**



**DIMBTDA**

**Sensore con Varialuce  
Sensor with dimmer**



**HBTDA**

**Rilevatore di movimento ON-OFF  
ON-OFF motion detector**



**BC360A-D02/BT**

**Alimentatore  
Driver**



**RN9168/BT**



## App proprietaria da scaricare gratuitamente:

- Configurazione rapida.
- Gestione della luce, degli scenari ON-OFF, dimmerazione, Timer astronomico, Ritmo circadiano.
- Programmazione dei singoli apparecchi Bluetooth 5.0 SIG MESH
- Password di sistema e diversi livelli di autorizzazione.
- Schedulazione di ogni programmazione con salvataggio in Cloud.
- Richiamo degli scenari e dimmerazione tramite qualsiasi pulsante normalmente aperto.

## Proprietary app to download for free:

- Quick configuration.
- Management of light, ON-OFF scenarios, dimming, astrological timer, circadian rhythm.
- Programming on individual devices Bluetooth 5.0 SIG MESH
- System password and different authorisation levels.
- Scheduling of each programming with Cloud storage.
- Recalling of the scenarios and dimming via any normally open button.



cod. HBTDA

## Sensore di movimento e crepuscolare con Varialuce integrato:

- è il **software**, è l'**hardware** del sistema integrato nell'apparecchio.
- Funzione MASTER e SLAVE.
- Dimmer (DALI) in Bluetooth 5.0 SIG MESH funzione ON-OFF, temporizzazione.
- Applicazione ad incasso o plafone.

## Motion and twilight sensor with integrated Dimmer:

- it is the **software**, the **hardware** of the system integrated into the device.
- MASTER and SLAVE function.
- Dimmer (DALI) in Bluetooth 5.0 SIG MESH function, timing.
- Recessed or ceiling-mounted application.



cod. HBTDAP  
Accessorio per montaggio a plafone  
Ceiling mount accessory

	Lenti incluse nella confezione <i>Lenses included in the package</i>	Rilevamento max (DxH) Max detection (DxH)	Asimmetrica <i>Asymmetric</i>	Per corridoi for corridors
Convessa <i>Convex</i>		10m x 3m		
Piatta <i>Flax</i>		9m x 3m		

Schema di collegamento - *Wiring diagram*

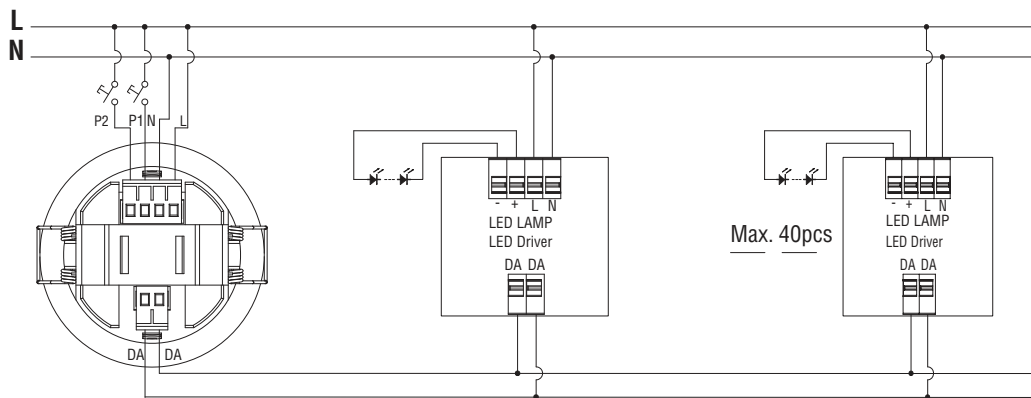

- Max 40 apparecchi  
Max 40 devices
- Max 35m





Code: **DIMBTDA** **DALI**

- Max 40 apparecchi (DALI)  
Max 40 devices (DALI)
- Max 35m

### Dimmer **DALI**:

- Dimmer 0-10V in **Bluetooth 5.0** SIG MESH funzione ON-OFF, dimmerazione e temporizzazione.
- Dimmer **DALI** in **Bluetooth 5.0** SIG MESH funzione ON-OFF, dimmerazione e temporizzazione.
- Funzione MASTER e SLAVE.
- Installazione in scatola 503, a bordo lampada e... ..dove ritenete necessario.

### Dimmer **DALI**:

- Dimmer 0-10V in **Bluetooth 5.0** SIG MESH ON-OFF function, dimming and timing.
- Dimmer **DALI** in **Bluetooth 5.0** SIG MESH function, dimming and timing.
- MASTER and SLAVE function.
- Application in recessed box 503, in the lamp or...where necessary.

Schema di collegamento - *Wiring diagram*

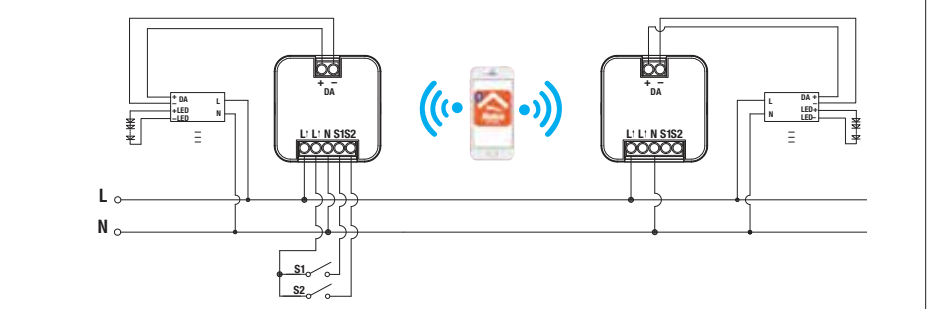

Code: **DIME27**

- Max 40 apparecchi  
Max 40 devices
- Max 35m

### Dimmer per E27 :

- Dimmer **Bluetooth 5.0** SIG MESH a taglio di fase, funzione ON-OFF, dimmerazione e temporizzazione.
- Dimmer per utilizzo con sorgenti luminose E27 dimmerabili con protocollo trailing edge.
- Installazione in scatola 503, a bordo lampada e... ..dove ritenete necessario.

### Dimmer for E27 :

- Dimmer **Bluetooth 5.0** SIG MESH phase cut, ON-OFF function, dimming and timing.
- Dimmer compatible with E27 light sources dimmable with trailing edge.
- Application in recessed box 503, in the lamp or...where necessary.

Schema di collegamento - *Wiring diagram*

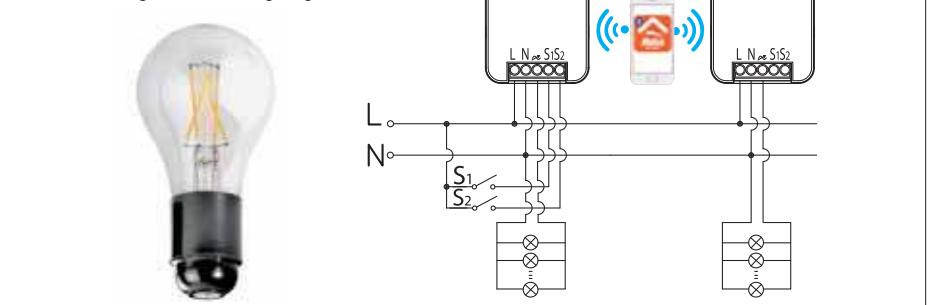

Code: **DIMBTDIM** **0-10V**

- Max. 10 Geräte (0-10V)  
Max. 10 appareils (0-10V)
- Max 35m

### Dimmer **0-10V**:

- Dimmer 0-10V in **Bluetooth 5.0** SIG MESH funzione ON-OFF, dimmerazione e temporizzazione.
- Portata contatto relè 0-10V. max 400W
- Funzione MASTER e SLAVE.
- Installazione in scatola 503, a bordo lampada e... ..dove ritenete necessario.

### Dimmer **0-10V**:

- Dimmer 0-10V in **Bluetooth 5.0** SIG MESH ON-OFF function, dimming and timing.
- Maximum capacity contact relay 0-10V. 400W.
- MASTER and SLAVE function.
- Application in recessed box 503, in the lamp or...where necessary.

Anschlussplan - *Diagramme de connexion*

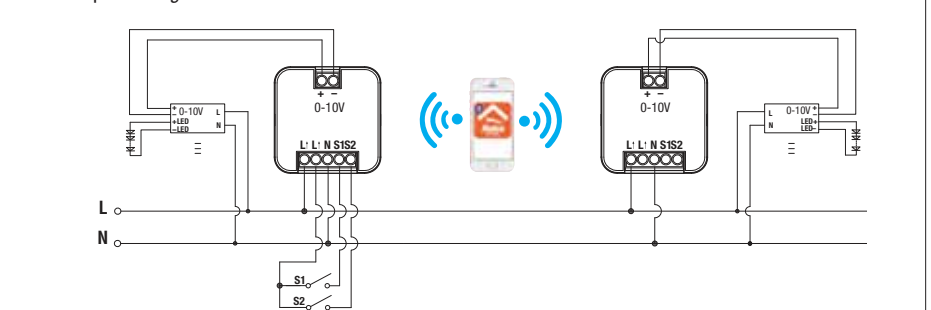



Code **BC360A-D02/BT**

## Rilevatore di MOVIMENTO ON-OFF a microonde con crepuscolare

**Bluetooth 5.0 SIG MESH** per impostazione soglia Lux ambiente di intervento, questa tecnologia consente di "nascondere" il rilevatore anche all'interno di corpi lampada infatti esso emette onde elettromagnetiche ad alta frequenza (5.8GHz) e riceve la loro propagazione, in questo modo è in grado di riconoscere una qualsiasi variazione data da un oggetto non rilevato nella precedente analisi e verrà dato il comando di ON.

- Trasmissione ad alta frequenza <10mW e risulta essere 100 volte inferiore alle emissioni di un comune telefono cellulare o di un forno a microonde che emettono mediamente 1000mW.

## ON-OFF microwave motion sensor with twilight sensor

**Bluetooth 5.0 SIG MESH** for setting the Lux level of the work environment, this technology enables to "hide" the detector even inside the fixture. In fact, it emits high frequency electromagnetic waves (5.8GHz) and receives their echo, thus being able to recognise any variation given by an object not detected in the previous analysis and the ON command will be issued.

- High frequency transmission <10mW and 100 times lower than the emissions of a common mobile phone or microwave oven which emit 1000mW on average.

Schema elettrico di rilevamento  
Detection diagram

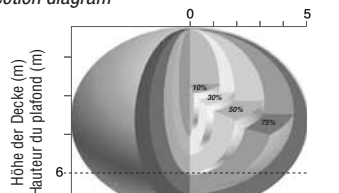

Erfassungsschema für die Deckenmontage (m)  
Schéma de détection plafond (m)

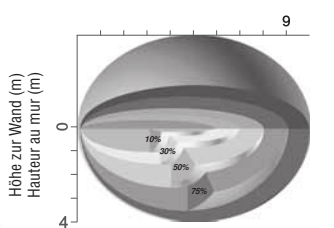

Erfassungsschema für die Wandmontage (m)  
Schéma de détection mural (m)

Schema di collegamento  
Wiring diagram

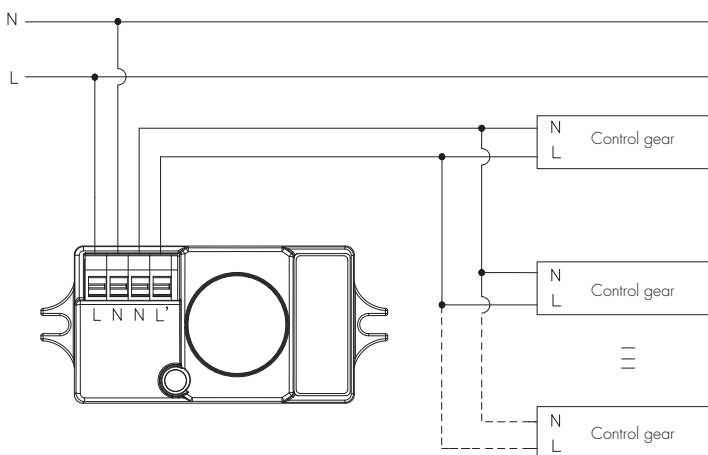

Accessorio - Accessory  
Cod. SAM22



Sensore di movimento e luminosità, cavo 650mm.  
Motion sensor and brightness, cable 650mm.

Code **RN9168/BT**

## Led Driver settabile:

- Alimentatore multipotenza **Bluetooth 5.0 SIG MESH** fornito di dip-switch per la selezione della corrente in uscita
- è il software, è l'hardware del sistema integrato nell'apparecchio.
- Funzione MASTER e SLAVE.
- Funzione on off -Dimmer e White Tunable.

## Settable LED Driver:

- Multi-power Driver **Bluetooth 5.0 SIG MESH** equipped with dip-switch to select the output current
- it is the software, the hardware of the system integrated into the device.
- MASTER and SLAVE function.
- On off -Dimmer and White Tunable function.

	mA	400	500	600	700	800	900	1000
	Vdc	45	45	45	45	45	45	45
	W	16	20	25	30	35 (30)	40 (30)	45 (30)
<b>N° LED typical VF 3,2V</b>	min-max	1÷14	1÷14	1÷14	1÷14	1÷14	1÷14	1÷14
<b>COB - Typical VF 37V</b>								

## Console di comando a pulsante ad induzione:

Sistema di comando **Bluetooth 5.0 SIG MESH** ad induzione.

Sono possibili diversi scenari di funzionamento es:

- ON-OFF
- Dimmerazione

## Induction pushbutton control console:

Induction control system **Bluetooth 5.0 SIG MESH**

Various operating scenarios are possible, e.g.:

- ON-OFF
- Dimming



Code **EWSDB**



Code **GATEWAY01**

## Gateway

Il gateway GATEWAY01, offre un rapido e semplice accesso remoto alla rete mesh Bluetooth. Facilita la trasmissione dei dati tra rete mesh ed Ethernet cablata o wireless.

L'uso di GATEWAY01 consente la raccolta di dati IoT, l'accesso / monitoraggio remoto, la sincronizzazione della rete in tempo reale e anche la possibilità di una facile risoluzione dei problemi nelle applicazioni reali.

Gateway GATEWAY01 offers a quick and easy way of remote access to Bluetooth mesh network. It facilitates the data transmission between mesh network and Ethernet wired or wirelessly. The use of GATEWAY01 enables IoT data gathering, remote access/monitoring, network real-time synchronization, and also the possibility of easy trouble-shooting in real applications.

Dimensioni prodotto Product dimensions	105x105x25mm
CPU	Allwinne H6.up to 1,5Ghz
GPU	Mali-T720
RAM	4G DDR III
ROM	32G
DC In	DC5V/2A
Lan	RJ45 Ethernet port (100M)

Dual Wifi	2,4G + 5G (AC 2x2)
BT	BT4
Indicatore potenza Power indicator	Power On: Blue
Bluetooth range	Max 10m
Norme di riferimento Safety and EMC	EN-60950-1; EN-301489-17; EN-301489-1; EN-30328
Temperatura di esercizio Operation temperature	Ta: -35...70°C
Grado IP IP rating	IP20

WORK  
in progress



Code **HBTDAIP65**

IP65



### Sensore di movimento e crepuscolare con Varialuce integrato:

- è il **software**, è l'**hardware** del sistema integrato nell'apparecchio.
- Funzione MASTER e SLAVE.
- Dimmer **(DALI)** in **Bluetooth 5.0 SIG MESH** funzione ON-OFF; temporizzazione.
- Applicazione ad incasso o plafone.

### Motion and twilight sensor with integrated Dimmer:

- it is the **software**, the **hardware** of the system integrated into the device.
- MASTER and SLAVE function.
- Dimmer **(DALI)** in **Bluetooth 5.0 SIG MESH** function, timing.
- Recessed or ceiling-mounted application.

WORK  
in progress



Code **HBIR29/UH**

IP65



### Sensore di movimento e crepuscolare Ultra High-Bay con Dimmer integrato:

- Lente convessa per rilevamento della singola persona fino a 20m di altezza
- Funzione MASTER e SLAVE.
- Dimmer **(DALI)** in **Bluetooth 5.0 SIG MESH** funzione ON-OFF; temporizzazione.
- Applicazione ad incasso o plafone.

### Motion and twilight Ultra High-Bay sensor with integrated Dimmer:

- Convex lens detection pattern for single person up to 20m height.
- MASTER and SLAVE function.
- Dimmer **(DALI)** in **Bluetooth 5.0 SIG MESH** ON-OFF function, scheduling.
- Recessed or ceiling-mounted application.

# Dimmer **DALI 2** PUSH

Potenziometro DALI per scatola tonda, montaggio a parete.

*DALI power potentiometer for round box, flush mounting.*



Articolo Article	DALI DALI Type	Consumo di energia Power consumption	Corrente in uscita Output current	ta	Peso Weight	Codice Code
		<b>W</b>	<b>mA</b>	<b>°C</b>	<b>Kg</b>	
SR-2400 RB	Type 6	max. 2,3	max. 100	0...+50	0,215	181205



**Tensione Nominale**  
*Rated Voltage*  
100 ÷ 240 V

**Frequenza**  
*Frequency*  
50-60 Hz

**Consumo di energia**  
*Power consumption*  
max. 2,3 W

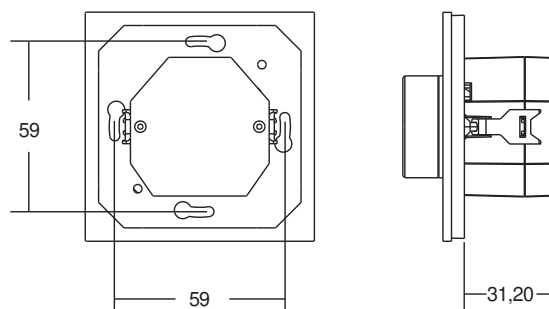

**Regolazione Dali, impianto tradizionale + due fili - Dali regulation, traditional system + two wires**

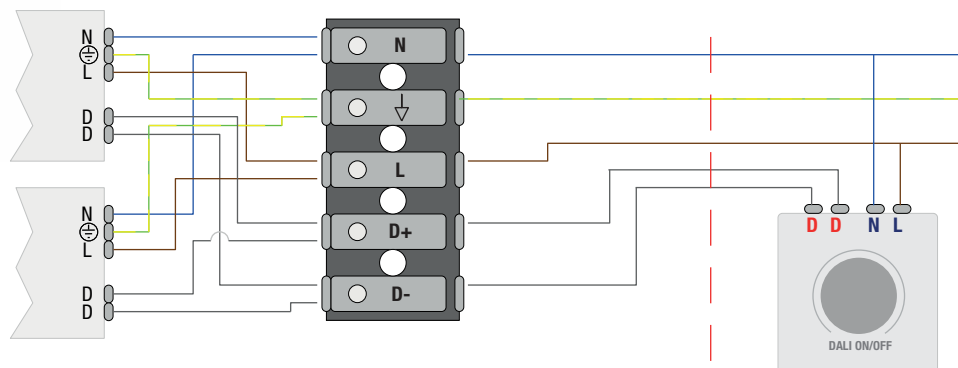

## Caratteristiche

- Progettato per funzionare con sistemi DALI-2.
- Unità di controllo DALI con alimentatore integrato.
- Consente un controllo della luminosità (trasmissione) sino ad un massimo di **50 drivers** senza alimentazione supplementare.
- Collegamento in parallelo di fino a **quattro potenziometri DALI** sino ad un massimo di **100 punti DALI**.
- Lunghezza del cavo di comunicazione DALI: max. 300 metri.
- L'utilizzo di ulteriore potenza potis DALI come estensione (senza il collegamento all'alimentazione integrata).
- Accensione e dimmerazione premendo e girando il pulsante di funzionamento.
- Memorizzazione della luminosità dimpostata e dell'ultima luminosità impostata.

## Features

- Designed to work with DALI-2 systems.
- DALI control unit with integrated power supply.
- Allows a common brightness control (broadcast) of up to **50 DALI drivers** without additional DALI power supply.
- Parallel switching of up to **four DALI power potis** extends the maximum number of **DALI stations to 100**.
- DALI communication cable length: max. 300 mt.
- Use of further DALI power potis as extension (without connection of the integrated power supply).
- Switching and dimming by pressing and turning the operation button.
- Storing of basic brightness and switch-on brightness.

# Systema centralizzato - Centralized system

Il sistema centralizzato con protocollo DALI attraverso una centrale controlla e/o alimenta tutti gli apparecchi di un impianto di illuminazione.

*The centralized system with DALI protocol through a control panel controls and/or supplies all the devices in lighting system.*

## ● COMFORT ED EFFICIENZA

DALI è un sistema standard condiviso dall'intero settore illuminotecnico. Il protocollo, incluso nella norma degli alimentatori elettronici EN60929, è definito nello specifico nella norma EN62386. Il protocollo DALI consente di far funzionare insieme i controlli dell'illuminazione, i sensori, gli apparecchi di comando, gli alimentatori elettronici e le lampade, comprese quelle d'emergenza, utilizzando una stessa interfaccia (MASTER DALI).

## ● I VANTAGGI DEI SISTEMI DALI

- Regolazione dell'intensità luminosa
- Individuazione rapida di malfunzionamenti
- Creazione di scenari diversi
- Nessun intervento manuale.

DALI consente di gestire l'intero impianto d'illuminazione associando un indirizzo ad ogni apparecchio luminoso. Inoltre è possibile raggruppare e memorizzare i prodotti luminosi oppure isolarne alcuni dal resto dell'impianto. Ad esempio, in questo modo è possibile regolare l'intensità luminosa di specifici gruppi o singoli prodotti illuminanti. Questa piattaforma intelligente gestisce anche le informazioni sullo stato delle lampade: accensione e spegnimento, status del funzionamento e la potenza del flusso luminoso. Inoltre, questo consente di rilevare in modo facile eventuali guasti nel sistema elettrico in quanto vengono raccolti ciclicamente messaggi sullo stato di ogni periferica. Tali impostazioni possono essere modificate senza intervenire fisicamente sull'impianto per riprogrammare la regolarità dei controlli.

## ● DALI ED EMERGENZA

Il più grande vantaggio reso disponibile dal DALI nel contesto dell'Emergenza è quello di avere un unico bus di campo per collegare l'illuminazione ordinaria e l'illuminazione di emergenza. Questo semplifica notevolmente il cablaggio dell'impianto (bus) e la programmazione di tutto il sistema di illuminazione. Collegando le lampade VENERE LED al bus DALI esse vengono indirizzate automaticamente.

## Lo Standard EN62386-202 permette:

- Il controllo dello stato della sorgente luminosa (Lampada LED).
- Il controllo della batteria.
- Fare o schedare test funzionali o di autonomia sul singolo apparecchio, per gruppi o sull'intero impianto.
- Controllare l'intensità luminosa sugli apparecchi (SE) solo emergenza.

## ● LEGENDA/LEGEND

- 

cod. 1957L12SAREL  
● Apparecchio di segnalazione LED Osiride DALI Autotest con segnali di sicurezza.  
*Osiride LED Signaling device DALI Self-test with safety signals.*
- 

cod. 1957L20SAREL (SA)  
cod. 1957L20SEREL (SE)  
● Lampada d'emergenza LED Osiride DALI Autotest con segnali di sicurezza.  
*Osiride LED Emergency device DALI Self-test with safety signals.*
- 

● Apparecchi di illuminazione ordinaria con Driver DALI.  
*Ordinary lighting fixtures with DALI driver.*
- 

Sensore  
Sensor
- 

cod. EDA4  
● Tastierino DALI (scene controller).  
*DALI Keypad (scene controller).*
- 

Master  
DALI BUS
- 

cod. DALI-P6-DIN  
● Master DALI BUS Power supply (max.6 scenari).  
*Master DALI BUS Power supply (max.6 scenarios).*
- 

cod. HIR23/D2/R  
● Sensore DALI  
*DALI sensor*
- 

cod. LT-424  
● Dalì scene controller per pulsante (max.6 scenari).  
*Dali scene controller for push-button (max.6 scenarios).*
- 

cod. DALI-PROGRAM  
● Modulo di interfaccia da USB a un sistema DALI  
*Interface module from USB to a DALI system*

## ● COMFORT AND EFFICIENCY

DALI is a standard system shared by the entire lighting sector. The protocol, included in the electronic power supply unit standard EN60929, is defined specifically in EN standard 62386. The DALI protocol allows lighting controls, sensors, control devices, electronic power supply units and lamps, including emergency lamps, to be operated simultaneously by using the same interface (MASTER DALI).

## ● ADVANTAGES OF DALI SYSTEMS

- Light intensity adjustment
- Quick malfunction identification
- Creation of different scenarios
- No manual operation.

DALI enables to manage the entire lighting system by associating an address to each lighting device. It is also possible to group and store the lighting products or to isolate some of them from the rest of the system. For example, this way it is possible to adjust the light intensity of specific units or individual lighting products.

This smart platform also manages information on the status of the lamps: switch-on and switch-off, operating status and the power of the luminous flux. Additionally, this enables to easily detect any faults in the electrical system as messages on the status of each peripheral device are cyclically stored. These settings can be changed without physically operating on the system to re-program the frequency of the checks.

## ● DALI AND EMERGENCY

The greatest advantage provided by DALI in the context of Emergency is that of having a single field bus to connect normal lighting and emergency lighting.

This significantly simplifies the wiring of the system (bus) and the programming of the entire lighting system.

By connecting the VENERE LED lamps to the DALI bus, they are addressed automatically. EN Standard 62386-202 enables:

- To control the status of the light source (LED lamp).
- To control the battery.
- Make or schedule functional or autonomy tests on the individual device, by units or on the entire system.
- Check the luminous intensity on the emergency only (EM).

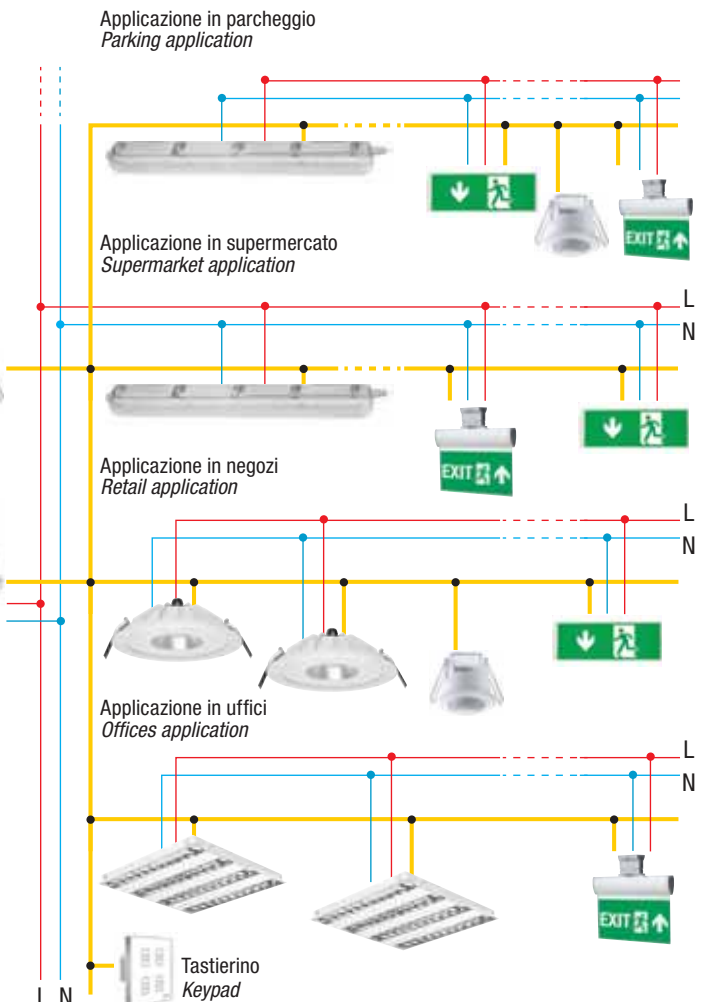

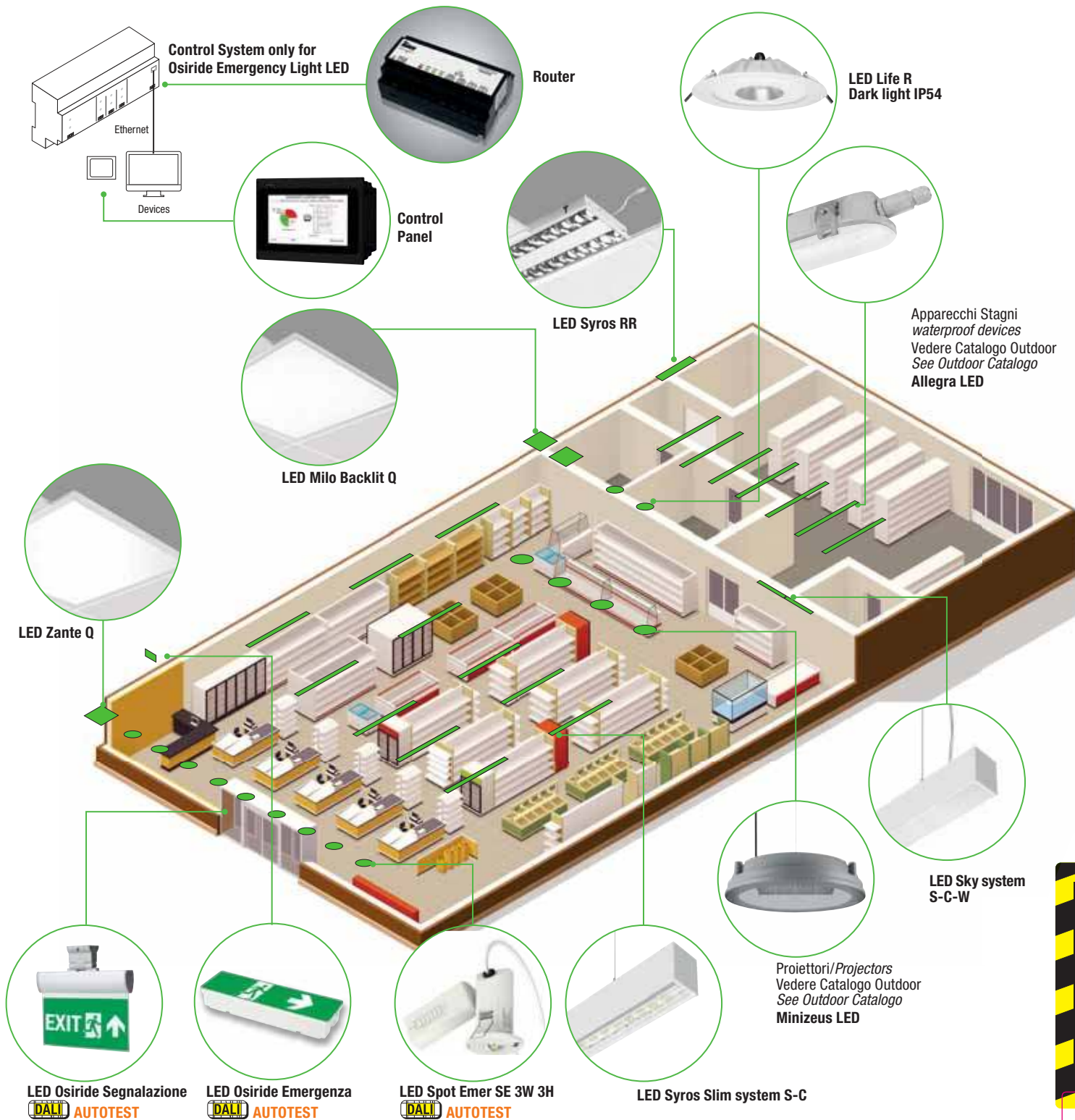

**LED Osiride Segnalazione**  
DALI AUTOTEST

**LED Osiride Emergenza**  
DALI AUTOTEST

**LED Spot Emer SE 3W 3H**  
DALI AUTOTEST

**LED Syros Slim system S-C**

Comando della luce indipendente per max. 192 apparecchi DALI su 3 linee DALI.  
Configurazione semplice con interfaccia WEB.  
Possibilità di comando trasversale della linea DALI.  
Pianificazione DALI del test di emergenza e sorveglianza (con sceneCOM XL EM e scene COM XL EM Bac, fino a 50 unità per luce di emergenza).  
A norma IEC 62034

**Caratteristiche armatura**

Tipo di protezione IP20  
Per montaggio su quadro elettrico ad armadio Interfacce.  
3 linee DALI.  
Interfaccia BACnet (sceneCOM XL EM Bac).

**Funzioni**

Assistente alla numerazione  
Comando basato sulle presenze  
Backup locale e scaricabile  
Libera programmazione dei giorni con funzione calendario  
Apparecchi per luce di emergenza a batteria singola  
Shows liberamente programmabili  
RGB e Tunable White  
Scene di luce e zone

*Independent light control for max. 192 DALI devices on 3 DALI lines.  
Simple configuration with WEB interface.  
Option of transversal control of the DALI line.  
DALI planning of the emergency test and surveillance (with sceneCOM XL EM and COM XL EM Bac scenes, up to 50 units per emergency light).  
Compliant with IEC standard 62034*

**Lighting characteristics**

*IP20 protection rating  
For assembly on Interface electrical cabinet.  
3 DALI lines.  
BACnet interface (sceneCOM XL EM Bac).*

**Functions**

*Numbering assistant  
Presence based command  
Local and downloadable backup  
Free programming of days with calendar function  
Single battery emergency lighting devices  
Freely programmable shows  
RGB and Tunable White  
Light scenes and zones*

# LED Syros R-C-S

A RICHIESTA  
ON DEMAND



Recessed-ceiling-suspended

Serie di apparecchi a LED per utilizzo a plafone, per aree comuni, corridoi, scale, laboratori, strutture sanitarie, sale riunioni, negozi, ecc. Adatte per controsoffitti a vista, disponibili con grado IP20 oppure in IP65.

**Installazione:** ad incasso in appoggio sulla struttura a "T" del controsoffitto, ad incasso (R) in controsoffitti di cartongesso (con accessori di montaggio), a plafone (C), a sospensione (S) (con accessori di montaggio).

**Corpo:** lamiera d'acciaio galvanizzato e verniciato a forno con resina di poliestere bianco RAL 9003.

**Optica:** parabola dark light in alluminio 99,85, speculare, antiriflesso e antiridescente a bassissima luminanza, schermo Policarbonato sagomato opalino a copertura dei vari circuiti LED. Per la versione IP65 schermo di protezione in vetro temperato trasparente.

**Conforme alla norma:** EN60598-1, RG0 nessun rischio fotobiologico ai fini della norma EN62471.

**LED: SAMSUNG** mantenimento del flusso luminoso minimo al 80%: L80B20>50.000h.

**Driver multipotenza:** Incluso > 50.000 h Fattore di potenza ≥0,95.

**Prodotto conforme alle direttive:**

*Range of LED ceiling fixtures for communal areas, corridors, staircases, laboratories, meeting rooms, shops, etc. Suitable for exposed false ceilings, available with IP20 or IP65 protection degree.*

**Installation:** recessed in support on the "T" structure of the false ceiling, recessed (R) in plasterboard false ceilings (with mounting accessories), surface-mounted (C), suspension (S) (with mounting accessories).

**Body:** steel sheeting galvanised and oven-painted with RAL 9003 white polyester resin.

**Optics:** dark light parabola in aluminium 99.85, specular, antireflective and anti-iridescent at very low luminance, screen of shaped opaline polycarbonate to cover the different LED circuits. For the IP65 version, clear tempered glass protection screen.

**According to standard:** EN60598-1, RG0 exempt from photo-biological risks in compliance with standard EN62471.

**LED: SAMSUNG** maintenance of minimum luminous flux to 80%: L80B20>50.000h.

**Driver: multipower** > 50.000 h Power factor ≥0,95.

**Product compliant with directives:**

## Dati fotometrici - Photometric data

LED Syros QR - QC - 60x60

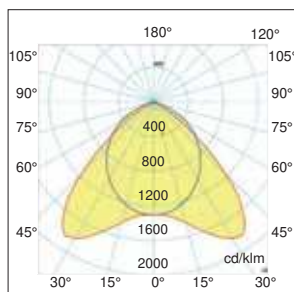

LED Syros RR - RC - 30x120

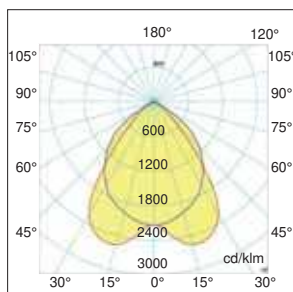



**Ottica Dark Light contro l'abbagliamento - Anti-glare dark light optics**

Gli apparecchi Dark Light limitano il pericolo di abbagliamento diretto e riflesso riducendo la luminanza nella direzione di osservazione, in riferimento a degli angoli limite. Indicati per postazioni di lavoro con videotermini.

*Dark Light devices limiting the danger of direct glare and reflection by reduction of the luminance in the direction of the relative point of observation, regarding the limit angles. Suitable for workstations with video terminals.*

Limite della luminanza media per angoli di elevazione di 65° ed oltre. UNI-EN12464-1			
Limite della luminanza media per angoli di elevazione di 65° ed oltre. UNI-EN12464-1			
Classe dello schermo secondo la ISO 9241-7 Screen class according to ISO 9241-7	I	II	III
Qualità dello schermo Screen quality	Buona Good	Media Average	Bassa Low
Luminanza media degli apparecchi che sono riflessi nello schermo Medium luminance of devices reflected in the screen	≤ 1.000 cd x m <sup>-2</sup>		≤ 200 cd x m <sup>-2</sup>
Parametri LED Syros - LED Syros parameter			

**Collegamento rapido  
Quick connection**



Per una più rapida installazione tutti i modelli di incasso sono dotati di cavo con morsetto per collegamento rapido.

*For faster installation, all the flush mounting models are equipped with a cable with a terminal for quick connection.*

**Pellicola di protezione  
Protective film**



Dotata di pellicola di protezione di serie per non sporcare il corpo lampada e le ottiche, in fase di trasporto e di installazione.

*Standard equipped with protective film so as not to dirty the bulb body and the optics during transport and installation, for maximum equipment performance.*

**LED performance  
LED performance**



Fattore di potenza ≥0,95 - mantenimento del flusso luminoso minimo al 80%: L80B20>50.000h. - Temperatura colore 4000K, a richiesta 3000K, 6000K.

*≥0.95 power factor - maintenance of minimum luminous flux to 80%: L80B20>50.000h. - Colour temperature 4000K, 3000K, 6000K on request.*

**UGR Indice di abbagliamento - Unified Glare Rating**

UGR	Classificazione valori UGR in funzione delle applicazioni. UGR value classification based on application.
≤ 16	<b>Applicazioni molto impegnative</b> (disegni tecnici, lavoro a videoterminale). <i>Highly demanding applications</i> (technical drawings, working with video display terminals).
≤ 19	<b>Uffici e scuole</b> (lettura, scrittura, riunioni). <i>Offices and schools</i> (reading, writing, meetings).
≤ 22	Applicazioni industriali, artigianato. <i>Industrial, artisanal applications.</i>
>28	Abbagliamento elevato. <i>High glare.</i>

**Fattore di abbagliamento UGR<19**

Valore contemplato secondo la norma (coefficiente di riflessione: soffitto 0,7 - pareti 0,5).

**Factor glare UGR<19**

Value calculated according to the standard (reflection coefficient: ceiling 0.7 - walls 0.5)

L'UGR è l'indicatore dell'abbagliamento diretto derivante dall'impianto di illuminazione. La norma Europea per l'illuminazione dei posti di lavoro in interni **UNI-EN12464-1** richiede un valore UGR specifico per ogni applicazione, compreso tra 10 e 30. Più è basso il valore, minore è l'abbagliamento.

Il valore esatto di tale indice è da calcolare su progetto in quanto dipende dalla disposizione degli apparecchi illuminanti, dalle caratteristiche dell'ambiente (dimensioni, riflessioni) e dal punto di osservazione.

*UGR is the indicator to assess the direct glare coming from a lighting system.*

*The UNI-EN12464-1 European standard for lighting indoor workplaces requires a specific UGR value for every application, ranging between 10 and 30. The lower the value, the lower the glare.*

*The exact value of this rating must be calculated in the design, as it depends on how the lighting fixtures are arranged, the features of the space (dimensions, reflections), and the viewpoint.*

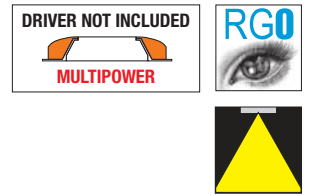
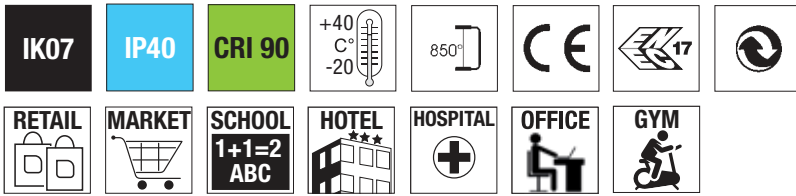

### LED Syros QR Recessed

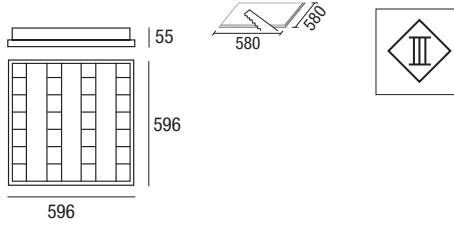

on demand 617mm

colour	W max	lm output max	K	pcs/pallets	Kg	S+L
B	44	4840	3000	60	3.00	25933/B/3K
B	44	4840	4000	60	3.00	25933/B

A richiesta versione 3000K e 6000K: (consegna 30gg.) **On demand 3000K and 6000K versions: (delivery 30 days)**

### LED Syros RR Recessed

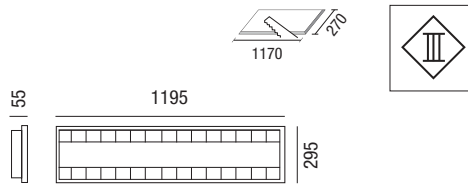
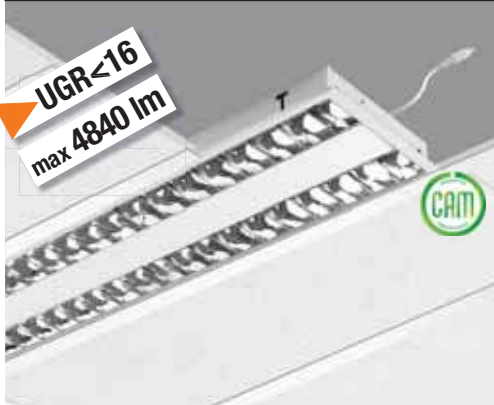

colour	W max	lm output max	K	pcs/pallets	Kg	S+L
B	44	4840	4000	60	3.750	25936/B

A richiesta versione 3000K e 6000K: (consegna 30gg.) **On demand 3000K and 6000K versions: (delivery 30 days)**



## Tabella di scelta potenza driver LED - LED Power supply table choice

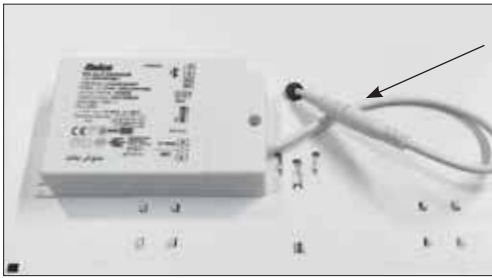

Driver con connessione rapida  
Driver with fast connection.

LED driver multipower

**RN9164/FAST (ON-OFF)**

**RN9168/FAST (1-10V.)**

**RN9168/DAFAST (DALI, PUSH,0-10V.)**

**RN8166DAPUFAS PUSH**

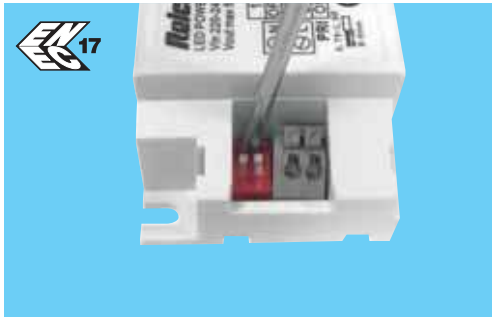

Fornito di dip switch per la selezione della corrente in uscita. Il driver incluso nella confezione è normalmente settato a 38W (vedi tabella). Se necessario è possibile diminuire o aumentare la potenza e di conseguenza i lumen output.

**Equipped with dip switch for selecting the current output.** The driver included inside the package is usually set to 38W (see table). If necessary it is possible to decrease or increase the power and consequently the lumen output.

Taratura Dip-switch	Potenza Power	Lm Output
mA	Watt	Lm
800	33	3630
900	38	4180
950	40	4400
1050	44	4840

Taratura standard di fabbrica  
Driver Standard factory setting

## Accessori non inclusi - Accessories not included

Cod. 65151LED80CP3



Cod. RP0714CP3

**AUTOTEST**



Cod. 65151LED80CP3

**L240x P59x H40**

Kit emergenza 3W - 3h/12% 180÷250 Vac  
180÷250 Vac - 3h/12% - 3W emergency kit

Cod. RP0714CP3 - **AUTOTEST**

**L195x P55x H42**

Kit emergenza 3W - 3h/12% 180÷250 Vac  
180÷250 Vac - 3h/12% - 3W emergency kit

### Apparecchi di illuminazione cablati in emergenza

Relco nella politica di offrire un servizio migliore alla clientela, ha deciso di utilizzare nei suoi apparecchi di illuminazione dotati di emergenza, solo INVERTER PER EMERGENZA CON AUTOTEST.

Relco in its policy of offering a better service to customers, has decided to use only EMERGENCY INVERTER WITH SELF-TEST in its luminaires equipped with emergency.

Le norme europee EN 1838, EN 60598-2-22, relative ai sistemi di illuminazione di emergenza, impongono che periodicamente, siano effettuati dei test per verificare sia il funzionamento sia l'efficienza (durata in emergenza) degli apparecchi di illuminazione che svolgono anche la funzione di illuminazione di emergenza. Questo costringe i manutentori dell'impianto ad interrompere la linea di alimentazione ed effettuare test con cadenza settimanale (test funzionale), e con cadenza trimestrale o annuale (test di autonomia).

Con i nostri kit di emergenza con autotest (conformi alla normativa europea EN 62034) queste prove vengono svolte automaticamente con cadenza programmabile in fase di installazione. Inoltre il nostro inverter analizza i tempi di normale accensione e spegnimento dell'apparecchio ed effettua (qualora possibile) i test nelle ore di assenza delle persone.

Eventuali anomalie sono segnalate tramite un indicatore (led) rosso verde.

A partire dal colore della segnalazione è possibile stabilire in maniera univoca gli eventuali problemi di funzionamento come evidenziato nella tabella seguente.

The European standards EN 1838, EN 60598-2-22, relating to emergency lighting systems, require that tests be periodically carried out to verify both the functioning and the efficiency (duration in emergency) of the lighting fixtures which also the emergency lighting function. This forces the system maintainers to interrupt the power supply line and carry out tests on a weekly basis (functional test), and on a quarterly or annual basis (autonomy test).

With our emergency kits with self-test (complying with European standard EN 62034) these tests are carried out automatically with a programmable cadence during installation.

Furthermore, our inverter analyzes the normal switching on and off times of the appliance and carries out (where possible) the tests in the hours when people are absent.

Any anomalies are signaled by a red-green indicator (led). Starting from the color of the signal, it is possible to unequivocally establish any functioning problems as shown in the following table.

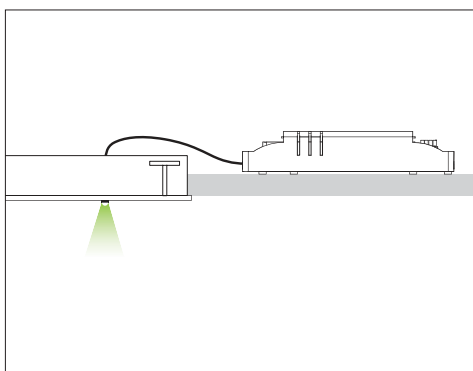

Colore LED - LED indication	Stato - Status
Verde fisso - Permanent Green	Batteria carica o in carica - Battery charge or charging
Verde lampeggiante - Flashing Green	Funzione TEST avviata - TEST in progress
Verde lampeggiante lento (1s ON - 1s OFF) Slow flashing green (1s ON - 1s OFF)	TEST di autonomia avviato Autonomy TEST in progress
Rosso fisso - Permanent Red	Lampada guasta - Lamp failure
Rosso lampeggio veloce (0,1s ON - 0,1s OFF) Fast flashing Red (0,1s ON - 0,1s OFF)	Guasto circuito di ricarica - Charging failure
Lampeggio Rosso lento (1s ON - 1s OFF) Slow flashing Red (1s ON - 1s OFF)	Batteria guasta - Battery failure
Verde e Rosso OFF - Green and Red OFF	Emergenza ON - Emergency ON



### LED Syros QC - plafone - ceiling

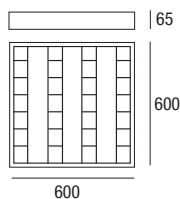
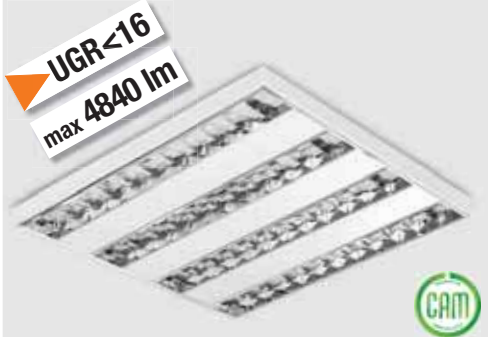

220 240V	50/60 Hz	
-------------	-------------	--

	colour	W max	lm output max	K	pcs/pallets	Kg	CELL
	B	44	4840	4000	60	3.30	25933/102
	B	44	4840	4000	60	3.30	25933/102DALI

**IP65 ON DEMAND** versione standard  
standard version

LED Driver multipotenza incluso nella confezione - LED driver multipower included inside the package  
**A richiesta:** versione 3000K e 6000K (consegna 30gg.) **On demand:** 3000K and 6000K versions (delivery 30 days)

### LED Syros RC - plafone - ceiling

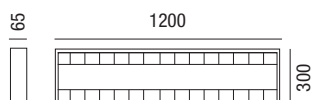
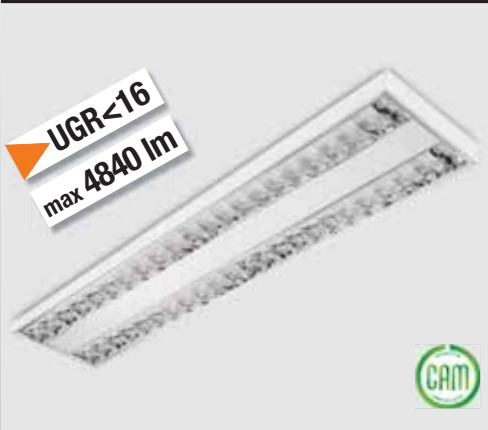

220 240V	50/60 Hz	
-------------	-------------	--

	colour	W max	lm output max	K		pcs/pallets	Kg	CELL
	B	44	4840	4000	1230	60	4.10	25936/104
	B	44	4840	4000	1230	60	4.10	25936/104DALI
	B	60	6600	4000	1230	60	4.10	25936/10460W
	B	60	6600	4000	1230	60	4.10	25936/10460WD

### Accessori non inclusi - Not included accessories

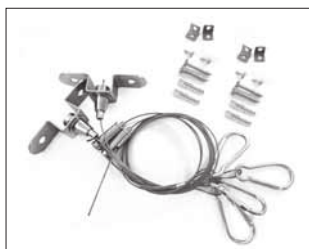

**Cod. 31300**  
Kit sospensione con cavo 2 m che consente di installare LED Syros Q e LED Syros R. Si consiglia l'installazione mantenendo una distanza di almeno 50/60 cm tra soffitto e plafoniera.  
Suspension kit with 2 m cable allows the suspended mounting of the LED Syros Q e LED Syros R. We recommend leaving at least 50/60cm between the ceiling and the lamp when installing it.

**Cod. 31300/ECO**  
Kit sospensione che consente di installare LED Syros Q e LED Syros R. Si consiglia l'installazione mantenendo una distanza di almeno 50/60cm tra soffitto e plafoniera.  
Suspension kit allows the suspended mounting of the LED Syros Q and LED Syros R. We recommend leaving at least 50/60cm between the ceiling and the lamp when installing it.

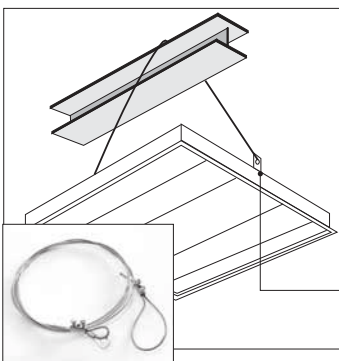
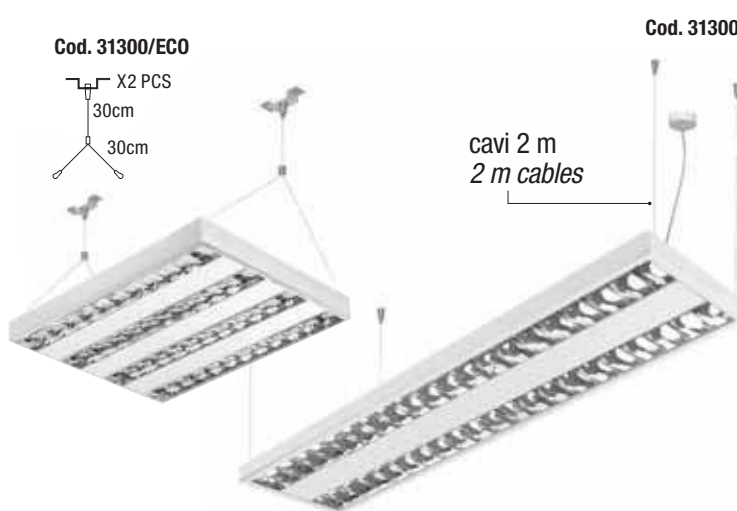

**Cod. 000/210**  
Kit sicurezza 1500mm, Ø1,5mm. Cavetto acciaio anticaduta per Led Syros da incasso.  
Safety Kit 1500mm, Ø 1,5mm. Steel fall arrest cable for flush mounting LED Syros

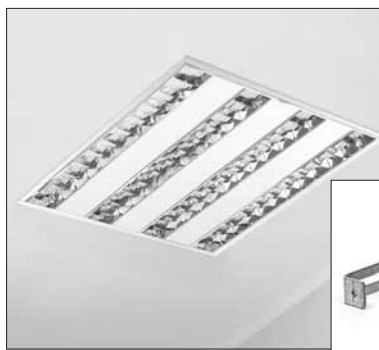

**Cod. 000120**  
"Kit staffe da incasso" per installazione in controsoffitti in cartongesso continuo.  
"Recessed bracket kit" for installation in cardboard false ceiling.



# RILEVATORI DI PRESENZA INFRAROSSI - INFRARED PRESENCE DETECTOR

	Code	W	VA	n°	V	Hz	ta °C
<b>0-10V</b>	<b>HIR22</b>	500 *	250 *	max 15	220-240	50/60	-20...50

	Code	V <sub>dc</sub>	n°	Hz	ta °C
<b>DALI 2</b>	<b>HIR23</b>	9,5÷22,5	max 64	8 mA	-20...50

**Rilevatore di PRESENZA ad infrarossi passivi con uscita DALI o 0-10V per la gestione di LED Driver dimmerabili; con crepuscolare per impostazione soglia Lux ambiente di intervento.**  
 Il sensore "percepisce" le variazioni di temperatura provocate dal movimento di persone o animali di grossa taglia entro la zona di copertura, accendendo e regolando automaticamente la luce in base al livello dei LUX impostato. Lo spegnimento si avrà, dopo l'arresto del movimento, in base al tempo precedentemente impostato. Grazie alle sue particolari lenti, il rilevatore, è in grado di **percepire non solo il movimento ma anche la PRESENZA** di uno o più individui all'interno dell'ambiente controllato.

**Passive infrared PRESENCE detector with DALI or 0-10V output for dimmable LED Drivers; with twilight function for Lux threshold setting within the range of intervention.**  
 The sensor "perceives" variations in temperature caused by the movement of people or big animals within the covered area, which automatically turns on the light, which is also based on the previously set level of environmental LUX. Shutdown will take place shortly after the motion within the range of detection stops, according to the previously set time.  
 Thanks to its particular lenses, the detector is able to perceive not only the movement but also the PRESENCE of one or more individuals within the controlled environment.

## Installazione ad incasso - Recessed installation

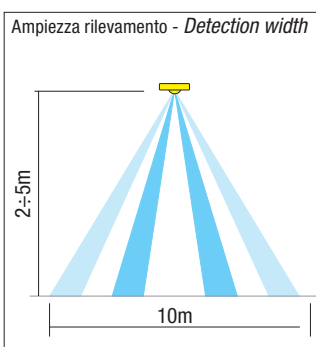
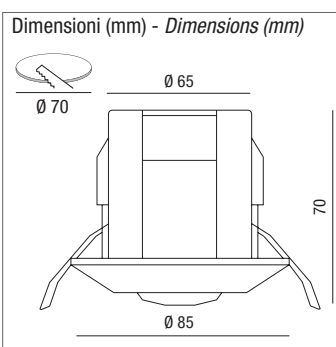

- Angolo di rivelamento: 360°
- Altezza di montaggio: 2÷5 metri
- Ampiezza rilevamento: Ø 10m
- Assorbimento stand by: < 0,5W
- Detection angle: 360°
- Assembly height: 2÷5 metres
- Detection Width: Ø 10m
- Stand-by absorption: < 0,5W



	Code	V <sub>dc</sub>	n°	ta °C
	<b>ES-GL01</b>	1-10	1...6	-20...50



Sistema di controllo dell'efficienza energetica, facile da usare, sicuro e pratico. Il sensore adotta la tecnologia di regolazione 1-10Vdc. in grado di sfruttare al massimo la luce naturale per aumentare l'efficienza energetica e ridurre i consumi.

Safe and practical energy efficiency control system. The sensor uses 1-10Vdc regulation technology capable of fully exploiting natural light to increase energy efficiency and to reduce consumption.

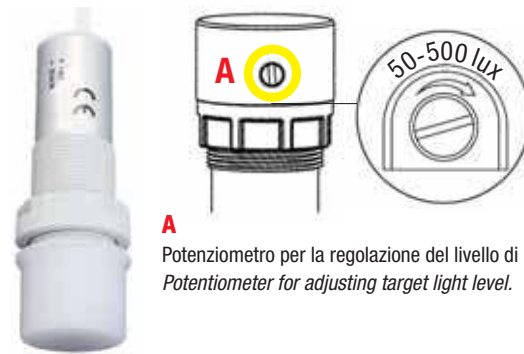

**A** Potenziometro per la regolazione del livello di luce. Potentiometer for adjusting target light level.

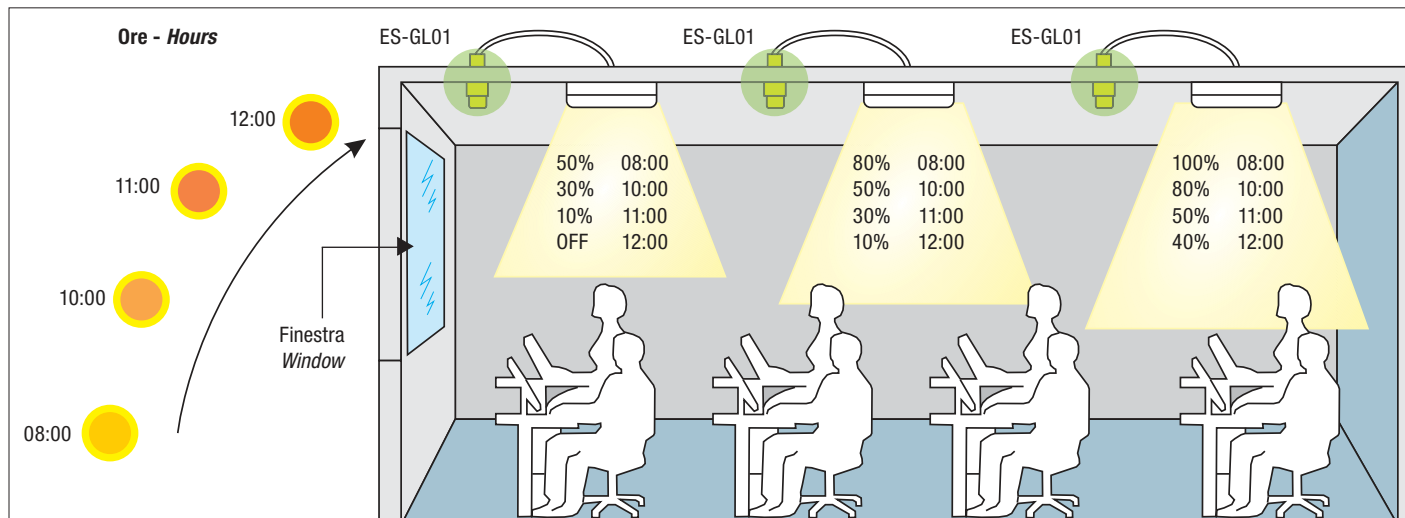

## LED Patmos lens R-C-S

A RICHIESTA  
ON DEMAND



Apparecchio a LED da incasso versione Backlite, di forma innovativa che garantisce una distribuzione ottimale della luce, adatto per controsoffitti a vista. Ideale per spazi di lavoro in cui è necessaria una luce diffusa perfettamente omogenea e un maggiore controllo dell'abbagliamento, conforme agli standard di comfort visivo ( $UGR \leq 16$ ).

**Installazione:** ad incasso in appoggio sulla struttura a "T" del controsoffitto, ad incasso in controsoffitti di cartongesso (con accessori di montaggio), a plafone (con accessori di montaggio), a sospensione (con accessori di montaggio).

**Corpo e telaio:** struttura in lamiera di acciaio elettrozincata, cornice in alluminio estruso EN AW 6060, verniciati con polvere termoindurente poliestere.

**Verniciatura:** di tipo poliestere eseguita a polvere. Colore bianco RAL 9003.

**Ottica:** diffondente con lenti secondarie in PMMA ad alta trasparenza e anti-ingiallimento.

**Diffusore:** PMMA di spessore 2mm.

**UGR:** Conforme alla norma EN 12464-1 -  $\leq 16$ .

**Temperatura colore:** di serie 3000K 4000K.

**Conforme alla norma:** EN60598-1, RG0 nessun rischio fotobiologico ai fini della norma EN62471.

**Led:** mantenimento del flusso luminoso minimo al 80%: L80B20>50.000h.

**Driver:** multipotenza . Fattore di potenza  $\geq 0,95$ .

**Prodotto conforme alle direttive:**

*Backlite version recessed LED luminaire, with an innovative shape that guarantees optimal light distribution, suitable for exposed false ceilings. Ideal for work spaces where perfectly homogeneous diffused light and greater glare control are required, compliant with visual comfort standards ( $UGR \leq 16$ ).*

**Installation:** lay-in installation on T-beams of false ceiling, recessed use in plasterboard false ceilings (with mounting accessories), ceiling use (with mounting accessories), suspended use (with mounting accessories).

**Body and frame:** structure made by galvanized steel sheet, frame made by EN AW 6060 extruded aluminum, coated with polyester thermoset powder.

**Coating:** coated with powdered polyester. RAL 9003 white color.

**Optic:** diffused with secondary lenses in high transparency and anti-yellowing PMMA.

**Diffuser:** PMMA with 2mm thickness.

**UGR:** According to Standard EN 12464-1 -  $\leq 16$

**Color temperature:** standard 4000K, 3000K.

**According to standard:** EN60598-1, RG0 exempt from photo-biological risks in compliance with standard EN62471.

**Led:** maintenance of minimum luminous flux to 80%: L80B20>50.000h.

**Driver:** multipower. Power factor  $\geq 0,95$ .

**Product compliant with directives:**



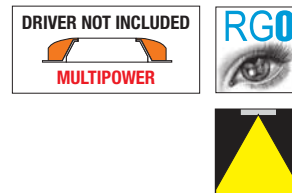
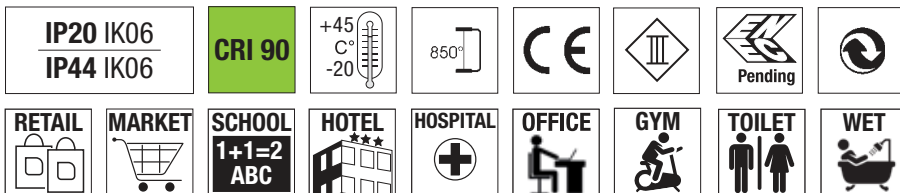

### LED Patmos QR lens

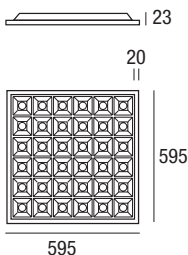
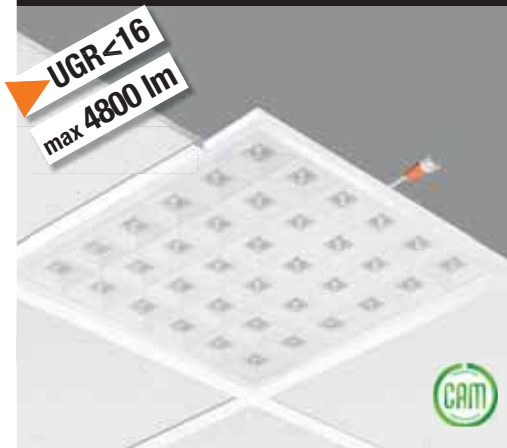

colour	W max	lm output max	K	pcs/pallets	Kg	S+L
B	40	4800	4000	60	3.00	24933/B4K

### Dati fotometrici Photometric data

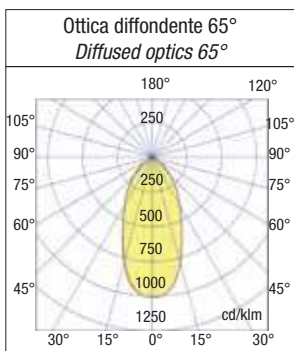

### Connessione rapida Rapid connection



Per una più rapida installazione tutti i modelli da incasso sono dotati di cavo con morsetto per collegamento rapido.  
*For quicker installation, all the recessed models are equipped of dedicated cable with fast connection terminal.*

### Facilità di installazione Easy installation

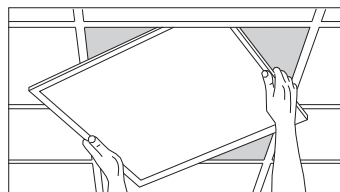

Facilità di installazione: connessione rapida senza necessità di apertura dell'apparecchio, facilmente inseribile nel plafone. Dopo l'installazione il prodotto non richiede manutenzione.  
*Easy installation: quick connection without having to open the device, easily installed in the ceiling. The device requires no maintenance after installation.*

### Flicker free

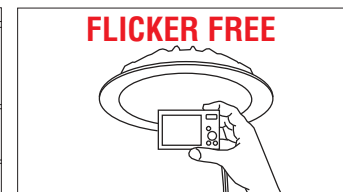



Luce uniforme per garantire un'ottimale protezione agli occhi.  
*flicker for greater eye protection.*

### Accessori non inclusi - Not included accessories



### Driver con connessione rapida Driver with fast connection



LED driver multipower   
**RN9164/FAST (ON-OFF)**  
**RN9168/FAST (1-10V.)**  
**RN9168/DAFAST (DALI, PUSH, 0-10V.)**  
**RN8166DAPUFAS  2 PUSH**



**Cod. 65151LED80CP3**  
Kit emergenza 3W - 3h/12% 180÷250 Vac  
180÷250 Vac - 3h/12% - 3W emergency kit

**Cod. RP0714CP3 - AUTOTEST**  
Kit emergenza 3W - 3h/12% 180÷250 Vac  
180÷250 Vac - 3h/12% - 3W emergency kit

### Tabella di scelta potenza driver LED - LED Power supply table choice



Fornito di dip switch per la selezione della corrente in uscita. Il driver incluso nella confezione è normalmente settato a 34W (vedi tabella). Se necessario è possibile diminuire o aumentare la potenza e di conseguenza i lumen output.

**Equipped with dip switch for selecting the current output.** The driver included inside the package is usually set to 34W (see table). If necessary it is possible to decrease or increase the power and consequently the lumen output.

Taratura Dip-switch	Potenza Power	Lm Output
mA	Watt	Lm
800	29	3480
900	34	4080
950	36	4320
1050	40	4800

Taratura standard di fabbrica  
Driver Standard factory setting



Cod. 31300 + 000102-M



Cod. 31300/ECO + 000102-M



Cod. 000102-M



**Accessori non inclusi - Not included accessories**

**Kit sospensione  
Suspension Kit**



**Cod. 31300**

Kit sospensione con cavo 2 m che consente di installare LED Syros Q e LED Syros R. Si consiglia l'installazione mantenendo una distanza di almeno 50/60 cm tra soffitto e plafoniera.

*Suspension kit with 2 m cable allows the suspended mounting of the LED Syros Q e LED Syros R.*

*We recommend leaving at least 50/60cm between the ceiling and the*



**Cod. 31300/ECO**

Kit sospensione che consente di installare LED Syros Q e LED Syros R. Si consiglia l'installazione mantenendo una distanza di almeno 50/60cm tra soffitto e plafoniera.

*Suspension kit allows the suspended mounting of the LED Syros Q and LED Syros R.*

*We recommend leaving at least 50/60cm between the ceiling and the lamp when installing it.*

**Kit sicurezza; cavo di sicurezza in acciaio  
Security Kit; safety steel wire**

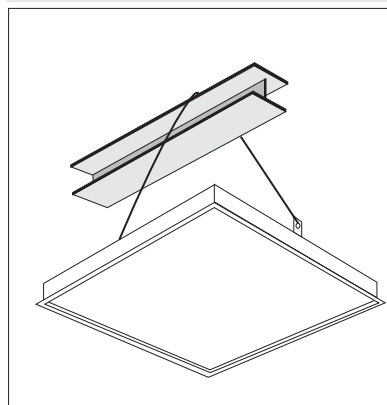

**Cod. 000/210**

Kit sicurezza: Lunghezza 1500mm, Ø 1,5mm. Cavo in acciaio anticaduta per Led Zante da incasso.

*Security kit. Length 1500mm, Ø1,5mm. Anti-fall steel cable for recessed Led Zante*



**Cod. 000/211**

Ganci per Kit sicurezza  
*Hooks for security kit*

**Montaggio per cartongesso - *Mounting for plasterboard***

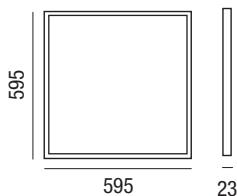

**Cod. 25930/CLIPS**

4 molle di fissaggio per installazione ad incasso in controsoffitti di cartongesso + 8 viti  
*4 fixing springs for recessed installation on plasterboard false ceiling + 8 screws*

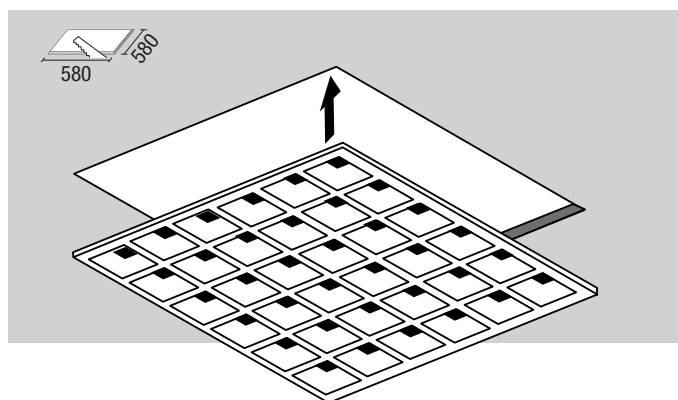

**Montaggio a plafone - *Ceiling mounting***

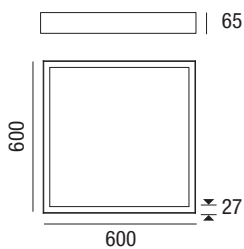

**Cod. 000102-M**

Cassaforma per installazione a **plafone**. Questo accessorio consente di montare LED Patmos direttamente a soffitto. La cassaforma è composta da un telaio componibile in lamiera verniciata bianca, costituito da quattro elementi ad incastro e viti a corredo.

*Coffer for ceiling installation. This accessory makes it possible to install the LED Patmos directly on a ceiling. The framework is composed of a modular frame in white painted sheet, consisting of four interlocking elements and screws supplied.*

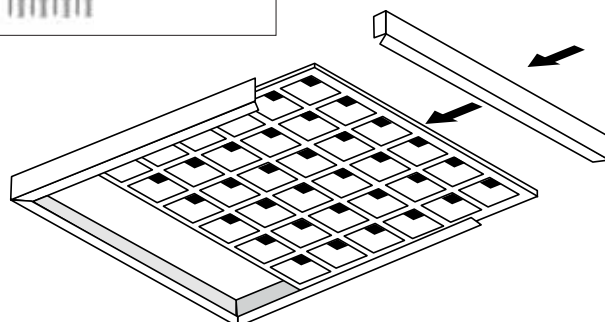

## LED Egeo R-C-S

A RICHIESTA  
ON DEMAND

0-10V



Serie di apparecchi a LED per aree comuni, corridoi, scale, laboratori, strutture sanitarie, sale riunioni, negozi, adatte per controsoffitti a vista. Per ambienti dove sia necessaria una luce diffusa perfettamente omogenea. Ideale per spazi di lavoro in cui è necessario un maggiore controllo dell'abbagliamento, grazie allo schermo microprismatizzato che fornisce un'illuminazione ottimale e rispettosa delle normative sul comfort visivo ( $UGR \leq 16$ ).

**Installazione:** ad incasso in appoggio sulla struttura a "T" del controsoffitto, a plafone (con accessori di montaggio), a sospensione (con accessori di montaggio).

**Corpo e telaio:** struttura in lamiera di acciaio elettrozincata, cornice in alluminio estruso EN AW 6060.

**Verniciatura:** di tipo poliestere eseguita a polvere. Colore bianco RAL 9010.

**Ottica:** lastra in policarbonato diffondente.

**Schermo:** microprismatizzato di spessore 2mm.

**UGR:** Conforme alla norma EN 12464-1 -  $\leq 16$ .

**Temperatura colore:** 4000K.

**Conforme alla norma:** EN60598-1, RG0 nessun rischio fotobiologico ai fini della norma EN62471.

**Led:** mantenimento del flusso luminoso minimo al 80%:  $L80B20 > 50.000h$ .

**Driver multipotenza:** non incluso, fattore di potenza  $\geq 0,95$  conforme alle norme.

**Prodotto conforme alle direttive:**

*Luminaire for recessed, ceiling or suspended installation designed to light up spaces requiring perfectly homogeneous diffused light.*

*It is suitable for modular false ceilings with exposed structure (lay-in installation) where it's necessary a higher glare control, the models with micro-prismatic shield supply an ideal lighting complying standards about visual comfort ( $UGR \leq 16$ ).*

**Installation:** lay-in installation on T-beams of false ceiling, ceiling use (with mounting accessories), suspended use (with mounting accessories).

**Body and frame:** structure made by galvanized steel sheet, frame made by EN AW 6060 extruded aluminum.

**Coating:** coated with powdered polyester. RAL 9010 white color.

**Optic:** polycarbonate sheet diffusing.

**Shield:** opal or micro-prismatic engineering plastic sheet with 2mm thickness.

**UGR:** According to Standard EN 12464-1 -  $\leq 16$

**Color temperature:** 4000K.

**According to standard:** EN60598-1, RG0 exempt from photo-biological risks in compliance with standard EN62471.

**Led:** maintenance of minimum luminous flux to 80%:  $L80B20 > 50.000h$ .

**Driver multipower:** not included. Power factor  $\geq 0,95$ , compliant with standards.

**Product compliant with directives:**



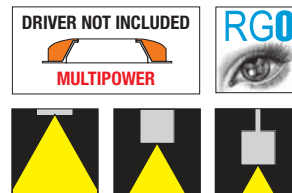
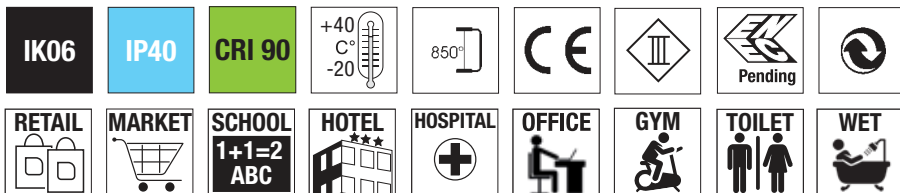

## LED Egeo Q

**UGR < 16**

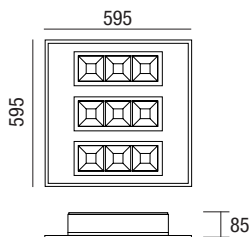

colour	W max	Lm output	K	pcs	Kg	S+L
B	35	4350	4000	001	3,50	27390-B

### Connessione rapida Rapid connection



Per una più rapida installazione tutti i modelli da incasso sono dotati di cavo con morsetto per collegamento rapido.  
*For quicker installation, all the recessed models are equipped of dedicated cable with fast connection terminal.*

### Facilità di installazione Easy installation

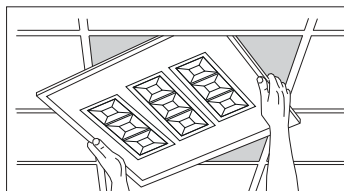

Facilità di installazione: connessione rapida senza necessità di apertura dell'apparecchio, facilmente inseribile nel plafone. Dopo l'installazione il prodotto non richiede manutenzione.  
*Easy installation: quick connection without having to open the device, easily installed in the ceiling. The device requires no maintenance after installation.*

### Flimmerfrei Sans scintillement



Luce uniforme per garantire un'ottimale protezione agli occhi.  
*Uniform light with no flicker for greater eye protection.*

### Dati fotometrici Photometric data

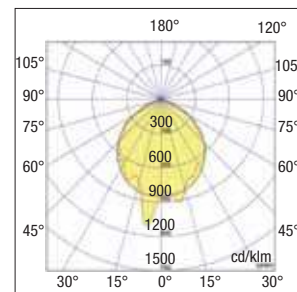

**Accessori non inclusi - Not included accessories**

**Kit sospensione  
Suspension Kit**



**Cod. 31300**

Kit sospensione con cavo 2 m che consente di installare LED Egeo Q. Si consiglia l'installazione mantenendo una distanza di almeno 50/60 cm tra soffitto e plafoniera.

*Suspension kit with 2 m cable allows the suspended mounting of the LED Egeo Q.*

*We recommend leaving at least 50/60cm between the ceiling and the lamp when installing it.*



**Cod. 31300/ECO**

Kit sospensione che consente di installare LED Egeo Q. Si consiglia l'installazione mantenendo una distanza di almeno 50/60cm tra soffitto e plafoniera.

*Suspension kit allows the suspended mounting of the LED Egeo Q.*

*We recommend leaving at least 50/60cm between the ceiling and the lamp when installing it.*

**LED DRIVER Multipower**

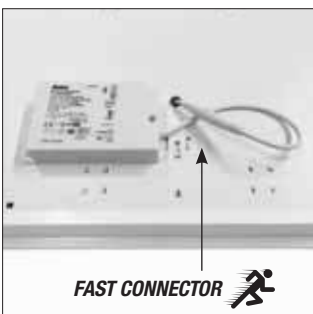

Driver con connessione rapida  
*Driver with fast connection.*

LED driver multipower

**RN9164/FAST (ON-OFF)**

**RN9168/FAST (1-10V)**

**RN9168/DAFAST (DALI, PUSH, 0-10V)**

**RN8166DAPUFAS**

**Kit emergenza - Emergency kit**



**Cod. 65151LED80CP3**

Kit emergenza 3W - 3h/12% 180÷250 Vac  
180÷250 Vac - 3h/12% - 3W emergency kit

**Cod. RP0714CP3 - AUTOTEST**

Kit emergenza 3W - 3h/12% 180÷250 Vac  
180÷250 Vac - 3h/12% - 3W emergency kit

**Tabella di scelta potenza driver LED - LED Power supply table choice**

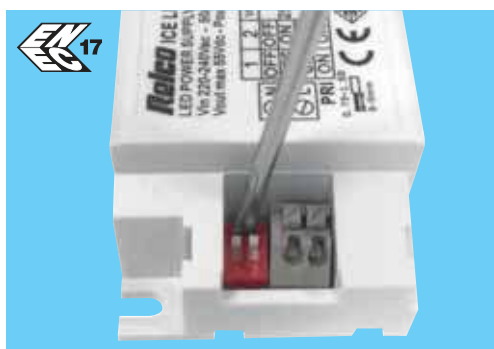

Fornito di dip switch per la selezione della corrente in uscita. Il driver incluso nella confezione è normalmente settato a 35W (vedi tabella). Se necessario è possibile diminuire la potenza e di conseguenza i lumen output.

**Equipped with dip switch for selecting the current output.** The driver included inside the package is usually set to 35W (see table). If necessary it is possible to decrease the power and consequently the lumen output.

Taratura Dip-switch	Potenza Power	Lm Output
mA	Watt	Lm
800	29	3600
900	33	4000
950	35	4350
Taratura standard di fabbrica Driver Standard factory setting		



**Cassaforma per installazione a plafone (non incassata).**

Questo accessorio consente di montare LED Egeo Q e LED Egeo R direttamente a soffitto. La cassaforma è composta da un telaio componibile in lamiera verniciata bianca, costituito da quattro elementi ad incastro e 4 viti a corredo.

**Coffer for ceiling installation (not recessed).**

*This accessory makes it possible to install the LED Egeo Q and LED Egeo R directly on a ceiling. The framework is composed of a modular frame in white painted sheet, consisting of four interlocking elements and 4 screws supplied.*

**Cod. 27390/CF  
LED Egeo Q 600x600mm**

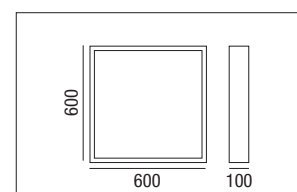

## LED Zante R-C-S

A RICHIESTA  
ON DEMAND



Serie di apparecchi a LED per aree comuni, corridoi, scale, laboratori, strutture sanitarie, sale riunioni, negozi, adatte per controsoffitti a vista. Per ambienti dove sia necessaria una luce diffusa perfettamente omogenea. Ideale per spazi di lavoro in cui è necessario un maggiore controllo dell'abbagliamento, grazie allo schermo micro-prismatizzato che fornisce un'illuminazione ottimale e rispettosa delle normative sul comfort visivo ( $UGR \leq 19$ ).

Per applicazioni in uffici ove ci siano attività lavorative svolte al videoterminale si consiglia l'utilizzo della serie SYROS o EGEO che hanno un maggior confort visivo grazie al  $UGR < 16$ .

**Installazione:** ad incasso in appoggio sulla struttura a "T" del controsoffitto, ad incasso in controsoffitti di cartongesso (con accessori di montaggio), a plafone (con accessori di montaggio), a sospensione (con accessori di montaggio).

**Corpo e telaio:** struttura in lamiera di acciaio elettrozincata, cornice in alluminio estruso EN AW 6060, verniciati con polvere termoindurente poliestere.

**Verniciatura:** di tipo poliestere eseguita a polvere. Colore bianco RAL 9003.

**Optica:** diffondente. Composta da lastra in tecnopolimero (MS).

**Schermo:** in materiale PMMA microprismatizzato, spessore 2mm.

**UGR:** Conforme alla norma EN 12464-1 -  $\leq 19$ .

**Temperatura colore:** 3000K, 4000K e 3CCT (3000K-4000K-6000K).

**Conforme alla norma:** EN60598-1, RGO nessun rischio fotobiologico ai fini della norma EN62471.

**Led:** mantenimento del flusso luminoso minimo al 80%:  $L80B20 > 50.000h$ .

**Driver:** multipotenza . Fattore di potenza  $\geq 0,95$ .

**Prodotto conforme alle direttive:**

*Luminaire for recessed, ceiling or suspended installation designed to light up spaces requiring perfectly homogeneous diffused light. It is suitable for modular false ceilings with exposed structure (lay-in installation) where it's necessary a higher glare control, the models with micro-prismatic shield supply an ideal lighting complying standards about visual comfort ( $UGR \leq 19$ ).*

*For applications in offices where there are work activities carried out at the video terminal, the use of the SYROS or EGEO series is recommended, which have a greater visual comfort thanks to the  $UGR < 16$ .*

**Installation:** lay-in installation on T-beams of false ceiling, recessed use in plasterboard false ceilings (with mounting accessories), ceiling use (with mounting accessories), suspended use (with mounting accessories).

**Body and frame:** structure made by galvanized steel sheet, frame made by EN AW 6060 extruded aluminum, coated with polyester thermoset powder.

**Coating:** coated with powdered polyester. RAL 9003 white color.

**Optic:** diffused. Engineering plastic sheet (MS).

**Shield:** PMMA micro-prismatic engineering plastic sheet with 2mm thickness.

**UGR:** According to Standard EN 12464-1 -  $\leq 19$

**Color temperature:** 3000K, 4000K e 3CCT (3000K-4000K-6000K).

**According to standard:** EN60598-1, RGO exempt from photo-biological risks in compliance with standard EN62471.

**Led:** maintenance of minimum luminous flux to 80%:  $L80B20 > 50.000h$ .

**Driver:** multipower. Power factor  $\geq 0,95$ .

**Product compliant with directives:**



Diffusore microprismatizzato in PMMA 0,75mm  
PMMA microprismatic diffuser 0,75mm

$UGR < 19$



Recessed-ceiling-suspended

**3CCT  
SWITCHABLE**

WW	NW	CW
▲ 3000K	▲ 4000K	▲ 6000K

Con cambio tonalità mediante selettore integrato posizionato sul corpo lampada è possibile scegliere la temperatura di colore preferita.

*With the integrated selector switch on the lamp body, you can choose your preferred color temperature.*

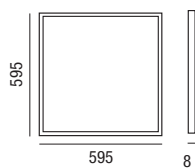
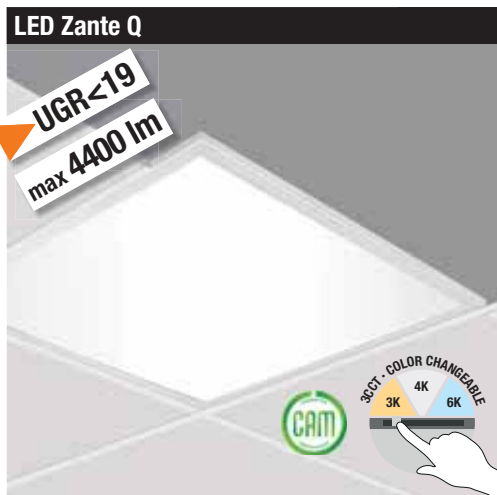
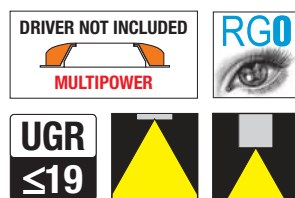
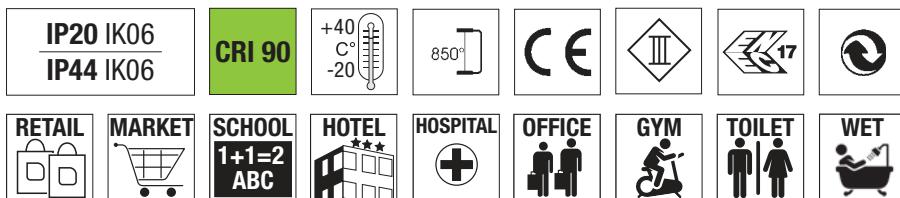

**NEW packaging**  
- In confezione da 10pcs.  
- 10 pcs packs.

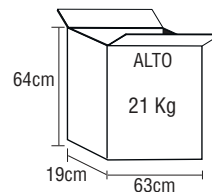

colour	W max	Lm output	K	pcs	Kg	S+L		
B	44	max 4400	4000	010	2,00	25930/B		
B	44	max 4400	3000	4000	6000	010	2,00	25932/B-

**3CCT SWITCHABLE**

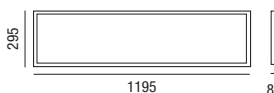
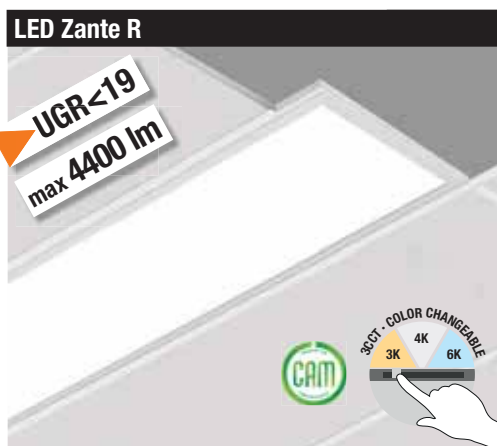

**NEW packaging**  
- In confezione da 10pcs.  
- 10 pcs packs.



colour	W max	Lm output	K	pcs	Kg	S+L		
B	44	max 4400	4000	010	3,20	26013/B		
B	44	max 4400	3000	4000	6000	010	3,20	26014/B-

**3CCT SWITCHABLE**

### Accessori non inclusi - Not included accessories

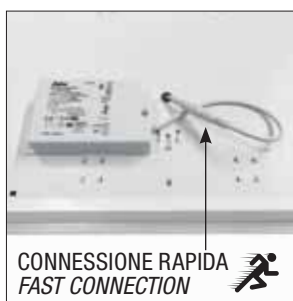

**Driver con connessione rapida**  
**Driver with fast connection**

LED driver multipower

**RN9164/FAST (ON-OFF)**

**RN9168/FAST (1-10V.)**

**RN9168/DAFAST (DALI, PUSH,0-10V.)**

**RN8166DAPUFAS 2 PUSH**



**Cod. 65151LED80CP3**

Kit emergenza 3W - 3h/12% 180÷250 Vac  
180÷250 Vac - 3h/12% - 3W emergency kit

**Cod. RP0714CP3 - AUTOTEST**

Kit emergenza 3W - 3h/12% 180÷250 Vac  
180÷250 Vac - 3h/12% - 3W emergency kit

### Tabella di scelta potenza driver LED - LED Power supply table choice

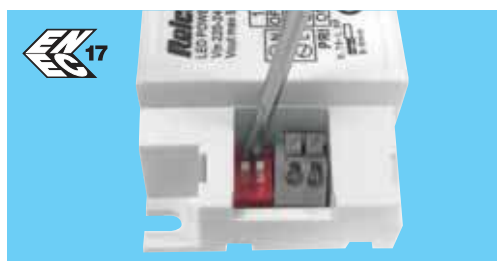

Fornito di dip switch per la selezione della corrente in uscita. Il driver incluso nella confezione è normalmente settato a 38W (vedi tabella). Se necessario è possibile diminuire o aumentare la potenza e di conseguenza i lumen output.

**Equipped with dip switch for selecting the current output.** The driver included inside the package is usually set to 38W (see table). If necessary it is possible to decrease or increase the power and consequently the lumen output.

Taratura Dip-switch	Potenza Power	Lm Output
mA	Watt	Lm
800	33	3300
900	38	3800
950	40	4000
1050	44	4400

Taratura standard di fabbrica  
Driver Standard factory setting

## Dati fotometrici Photometric data

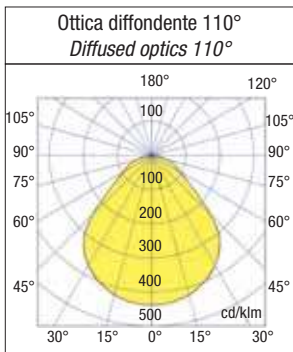

## Connessione rapida Rapid connection



Per una più rapida installazione tutti i modelli da incasso sono dotati di cavo con morsetto per collegamento rapido.  
For quicker installation, all the recessed models are equipped of dedicated cable with fast connection terminal.

## Facilità di installazione Easy installation

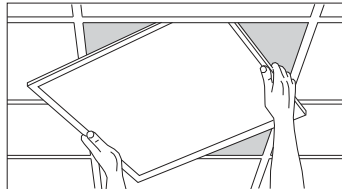

Facilità di installazione: connessione rapida senza necessità di apertura dell'apparecchio, facilmente inseribile nel plafone. Dopo l'installazione il prodotto non richiede manutenzione.  
Easy installation: quick connection without having to open the device, easily installed in the ceiling. The device requires no maintenance after installation.

## Flicker free



Luce uniforme per garantire un'ottimale protezione agli occhi.  
flicker for greater eye protection.

## Composizione lampada - Lamp composition

### Le qualità dello schermo microprismatizzato

LED Zante è dotato di schermo microprismatizzato per un elevato controllo dell'abbagliamento, creato da una lastra in **PMMA** (Polimetilmetacrilato) un polimero che non ingiallisce e mantiene inalterate le sue caratteristiche nel tempo. La qualità dei materiali utilizzati da Relco garantiscono un mantenimento del flusso luminoso minimo al 80%: **L80B20>50.000h** un'alta resa del colore (**CRI≤90**), assenza di abbagliamento (**UGR≤19**) e basso livello di Flickering.

### The qualities of the microprismatic screen

LED Zante is equipped with a micro-prismatic screen for high glare control, created from a **PMMA** (Polymethylmethacrylate) plate, a polymer that does not yellow and maintains its characteristics over time. The quality of the materials used by Relco guarantee a minimum luminous flux maintenance at 80%: **L80B20>50.000h** a high color rendering (**CRI≤90**), absence of glare (**UGR≤19**) and low level of Flickering.

Film E.V.A. (Ethilene vinil acetato) Spessore 2mm  
E.V.A. film - Thickness 2mm

Fondo di chiusura in acciaio verniciato Bianco  
Closure bottom made of steel; White Painted

Film riflettente - Spessore 0,25mm  
Reflective film - Thickness 0,25mm

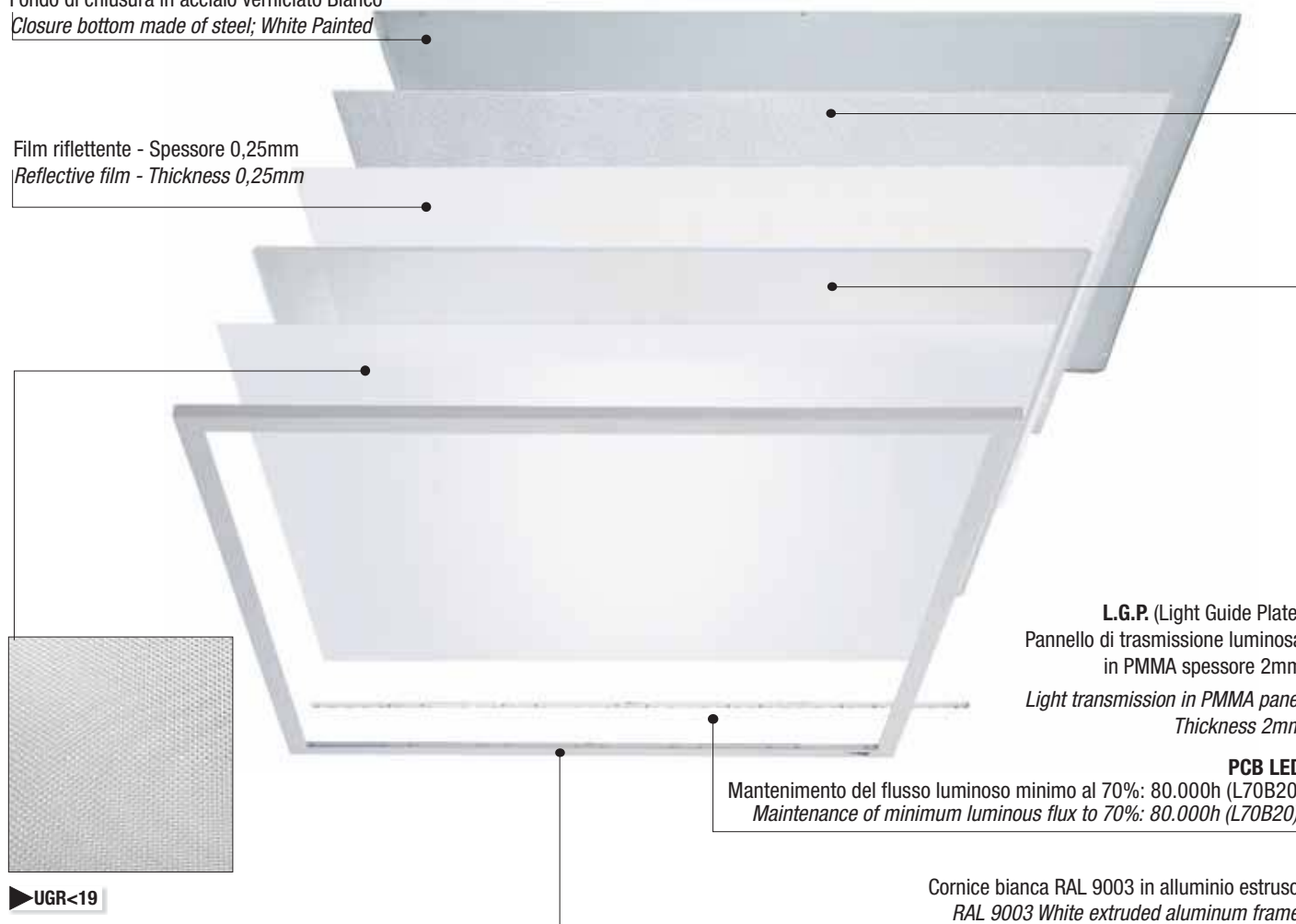

**L.G.P.** (Light Guide Plate)  
Pannello di trasmissione luminosa  
in PMMA spessore 2mm  
Light transmission in PMMA panel  
Thickness 2mm

**PCB LED**  
Mantenimento del flusso luminoso minimo al 70%: 80.000h (L70B20)  
Maintenance of minimum luminous flux to 70%: 80.000h (L70B20).

Cornice bianca RAL 9003 in alluminio estruso  
RAL 9003 White extruded aluminum frame

► **UGR<19**

Diffusore microprismatizzato 0,75mm  
Microprismatic diffuser 0,75mm

**Installazione con accessori per plafone cartongesso - *Plasterboard accessories ceiling installation***



**Cod. 25930/CLIPS**  
 4 molle di fissaggio per installazione ad incasso in controsoffitti di cartongesso + 8 viti  
 4 fixing springs for recessed installation on plasterboard false ceiling + 8 screws



**Cod. 000102 (000102-M)**  
**Cod. 000103 - LED Zante R 300x1200mm**  
**Cod. 000102 - LED Zante Q 600x600mm**  
 Cassaforma per installazione a plafone (non incassata). Questo accessorio consente di montare LED Zante Q e R direttamente a soffitto. La cassaforma è composta da un telaio componibile in lamiera verniciata bianca, costituito da quattro elementi ad incastro e viti a corredo.  
 Coffers for ceiling installation (not recessed). This accessory makes it possible to install the LED Zante Q or R directly on a ceiling. The framework is composed of a modular frame in white painted sheet, consisting of four interlocking elements and screws supplied.

**Installazione con accessorio a SOSPENSIONE - *Installation with SUSPENSION accessory***



**Cod. 31300**  
 Kit sospensione con cavo 2m che consente di installare LED Zante Q e LED Zante R (aggiungere anche accessorio 000103 cassaforma 300X1200). Si consiglia l'installazione mantenendo una distanza di almeno 50/60cm tra soffitto e plafoniera.  
 Suspension kit with 2 m cable allows the suspended mounting of the LED Zante Q and LED Zante R (also add accessory 000103 formwork 300X1200). We recommend leaving at least 50/60cm between the ceiling and the lamp when installing it.

**Cod. 31300/ECO**  
 Kit sospensione che consente di installare LED Zante Q e LED Zante R (aggiungere anche accessorio 000103 cassaforma 300X1200). Si consiglia l'installazione mantenendo una distanza di almeno 50/60cm tra soffitto e plafoniera.  
 Suspension kit with 2 m cable allows the suspended mounting of the LED Zante Q and LED Zante R (also add accessory 000103 formwork 300X1200). We recommend leaving at least 50/60cm between the ceiling and the lamp when installing it.

## LED Milo Backlit R-C-S

A RICHIESTA  
ON DEMAND

0-10V

DALI 2



Bluetooth



Apparecchio a LED per aree comuni, corridoi, scale, laboratori, strutture sanitarie, sale riunioni, negozi, adatte per controsoffitti a vista. Per ambienti dove sia necessaria una luce diffusa perfettamente omogenea. Ideale per spazi di lavoro in cui è necessario un maggiore controllo dell'abbagliamento, grazie allo schermo microprismatizzato che fornisce un'illuminazione ottimale e rispettosa delle normative sul comfort visivo (UGR≤19).

Per applicazioni in uffici ove ci siano attività lavorative svolte al videoterminale si consiglia l'utilizzo della serie SYROS, EGEO o ITACA che hanno un maggior confort visivo grazie al UGR<16.

**Installazione:** ad incasso in appoggio sulla struttura a "T" del controsoffitto.

**Corpo e telaio:** struttura in lamiera di acciaio elettrozincata, cornice in alluminio estruso EN AW 6060, verniciati con polvere termoindurente poliestere.

**Verniciatura:** di tipo poliestere eseguita a polvere. Colore bianco RAL 9003.

**Ottica:** diffondente. Composta da lastra in tecnopolimero (MS).

**Schermo:** Milo Basic - Milo HE diffusore opale.

Milo Plus diffusore prismatizzato.

**Conforme alla norma:** EN60598-1, RGO nessun rischio fotobiologico ai fini della norma EN62471.

**Led:** mantenimento del flusso luminoso minimo al 80%: L90B10>100.000h.

**Driver:** multipotenza . Fattore di potenza ≥0,95 **da ordinare a parte**.

**Prodotto conforme alle direttive:**

*LED appliance for common areas, halls, stairs, laboratories, healthcare facilities, meeting rooms, shops, suitable for visible false ceilings. For environments requiring perfectly evenly diffused light. Ideal for workspaces which need greater glare control, thanks to the microprismatic screen which provides optimal lighting and complies with standards on visual comfort (UGR≤19).*

*For applications in offices where work is carried out at video terminals, we recommend using the SYROS or EGEO or ITACA series which provide greater visual comfort thanks to UGR<16.*

**Installation:** recessed set on the T-shaped false ceiling structure.

**Body and frame:** electro-galvanised steel sheet structure, EN AW 6060 extruded aluminium frame, coated with thermosetting polyester powder.

**Painting:** powder polyester coating. White RAL 9003.

**Optics:** diffusing. Consisting of techno-polymer sheet (MS).

**Screen:** Milo Basic - Milo HE opal diffuser.

Milo Plus prismatic diffuser.

**Compliant with standard:** EN60598-1, RGO no photobiological risk for the purposes mentioned in standard EN62471.

**LED:** maintenance of 80% minimum luminous flux: L90B10>100.000h.

**Driver:** multi-power factor ≥0.95 **to be ordered separately**.

**Product compliant with directives:**



3CCT  
COLOUR  
CHANGING

3CCT  
SWITCHABLE

WW	NW	CW
▲	▲	▲
3000K	4000K	6000K

Con cambio tonalità mediante selettore integrato posizionato sul corpo lampada è possibile scegliere la temperatura di colore preferita.

*With the integrated selector switch on the lamp body, you can choose your preferred color temperature.*

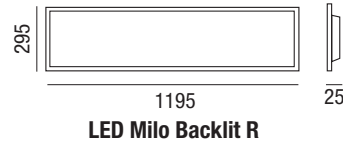
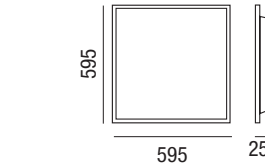
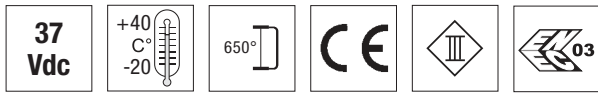

		colour	Wmax	Lm output	lm/W	K	pcs	Kg	S+L		
<b>BASIC series</b>	LED Milo Backlit Q 60X60	B	40	max 4400	110	4000	10	1,30	25938/B	UGR ≤ 19*	IP20 IK06 IP44 IK06
		B	40	max 4400	110	4000	10	1,30	25938/65/B	UGR ≤ 19*	IP20 IK06 IP65 IK06
<b>BASIC series</b>	LED Milo Backlit R 30X120	B	40	max 4400	110	3000K	10	1,30	25938B301203K	UGR ≤ 19*	IP20 IK06 IP44 IK06
		B	40	max 4400	110	4000	10	1,30	25938/B30120	UGR ≤ 19*	IP20 IK06 IP44 IK06
		B	40	max 4400	110	4000	10	1,30	2593865B30120	UGR ≤ 19*	IP20 IK06 IP65 IK06

		colour	Wmax	Lm output	lm/W	K	pcs	Kg	S+L				
<b>PLUS series</b>	LED Milo Backlit Q 60X60	B	40	max 4640	116	3000K	10	1,30	25938/BPLUS3K	UGR-19	IP20 IK06 IP44 IK06		
		B	40	max 4640	116	4000	10	1,30	25938/BPLUS				
		B	40	max 4610	116	3000	4000	6000	10	1,30	25938/BPLUS3K-	UGR-19	IP20 IK06 IP44 IK06
	LED Milo Backlit R 30X120	B	40	max 4400	110	3000	4000	6000	10	1,30	25938BPL30120-	UGR-19	IP20 IK06 IP44 IK06

**Milo HE** grande vantaggio economico, consumo ridotto e alta efficienza luminosa.  
**Milo HE** great economic advantage, low consumption and high luminous efficiency.

		colour	Wmax	Lm output	lm/W	K	pcs	Kg	S+L		
<b>HE series</b>	LED Milo Backlit Q 60X60	B	40	max 5600	147	4000	10	1,60	25938/BHE	UGR-19	IP20 IK06 IP44 IK06
	LED Milo Backlit Q 30X120	B	40	max 5600	147	4000	10	1,60	25938B30120HE	UGR-19	IP20 IK06 IP44 IK06

**Tabella di scelta potenza driver (non incluso) - LED Power supply table choice (not included)**

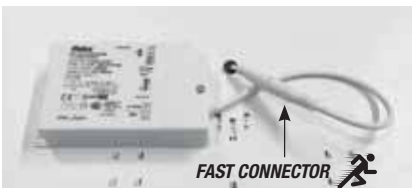

Driver con connessione rapida  
 Driver with fast connection.

**STANDARD 900mA**

- LED driver multipower **RN9164/FAST**
- RN9168/FAST** (1-10V.)
- RN9168/DAFAST** (DALI, PUSH, 0-10V.)
- RN8166DAPUFAS**



SCEGLI LA GIUSTA CORRENTE PER OTTIMIZZARE IL FLUSSO LUMINOSO NECESSARIO  
 CHOOSE THE RIGHT CURRENT TO OPTIMIZE THE NECESSARY LUMINOUS FLUX

Taratura Dip-switch	Potenza Power
mA	Watt
800	32
900	36
950	38
1050	40
	Taratura standard di fabbrica Driver Standard factory setting

Possibilità di scegliere la corrente di pilotaggio del LED **max 1050mA**, tenendo presente che la scelta di una corrente più bassa aumenterà l'efficienza e quindi migliorerà il risparmio energetico. In questo modo potrai scegliere il flusso luminoso ideale per ogni progetto illuminotecnico.

Possibility to choose the driving current of the LED **max 1050mA**, bearing in mind that choosing a lower current will increase efficiency and therefore improve energy savings. In this way you can choose the ideal luminous flux for each lighting project.

LED Milo Circle template

**NEW**



Circle template in metallo da utilizzare in abbinamento a Milo LED in appoggio alla struttura esistente.

**Verniciatura:** di tipo poliestere eseguita a polvere. Colore bianco RAL 9003, Arancio RAL 050 60 80, Cyan primario, giallo primario.

Circle template in metal to be used in combination with Milo LED in support of the existing structure.

**Painting:** polyester powder paint. Color white RAL 9003, orange RAL 050 60 80, primary cyan, primary yellow.

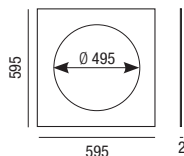

**Cod. 000104-OR**  
Circle template Arancio  
Circle template Orange



**Cod. 000104-WH**  
Circle template Bianco  
Circle template White



**Cod. 000104-YE**  
Circle template Giallo primario  
Circle template Yellow



**Cod. 000104-CY**  
Circle template Cyan  
Circle template Cyan

è possibile customizzare Circle template in altri colori, a richiesta per quantità con tempi di consegna 60giorni.

it is possible to customize Circle template in other colors, on request for quantities with delivery times of 60 days.



Accessori non inclusi - cassaforma da assemblare per installazione a plafone e molle di fissaggio per cartongesso  
Accessories not included - formwork to be assembled for ceiling installation and fixing springs for plasterboard

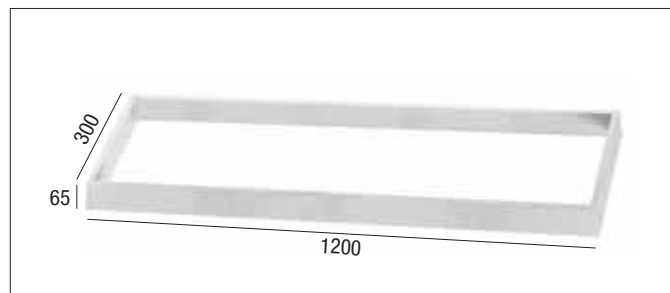
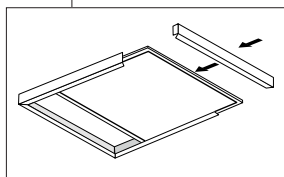
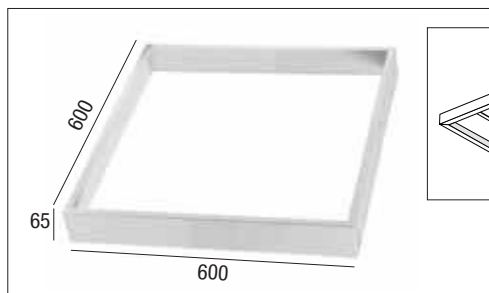

**Cod. 000102-M (versione quadrata)**

Cassaforma da assemblare per installazione a plafone. Questo accessorio consente di montare LED Milo Q direttamente a soffitto in modo veloce. La cassaforma è composta da un telaio componibile in lamiera verniciata bianca RAL 9003, costituito da quattro elementi ad incastro.

**Cod. 000103-M (rectangular version)**

Frame to be assembled for ceiling installation. This accessory makes it possible to install the LED Milo Q directly on a ceiling quickly. The framework is composed of a modular frame in RAL 9003 white painted sheet, consisting of four interlocking elements.

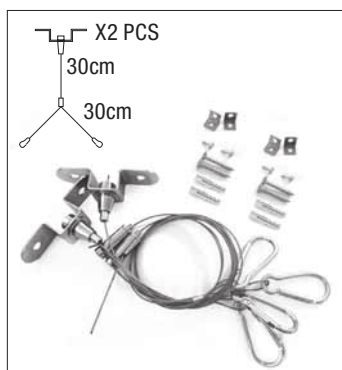

**Cod. 31300/ECO**

Kit sospensione che consente di installare LED Milo da aggiungere all'accessorio 000102-M (cassaforma 600X600) o 000103-M (cassaforma 300X1200). Si consiglia l'installazione mantenendo una distanza di almeno 50/60cm tra soffitto e plafoniera.

Suspension kit that allows you to install LED Milo to be added to the accessory 000102-M (600X600 formwork) or 000103-M (300X1200 formwork). We recommend leaving at least 50/60cm between the ceiling and the lamp when installing it.

**Cod. 25930/CLIPS**

4 molle di fissaggio per installazione ad incasso in controsoffitti di cartongesso + 8 viti.

4 fixing springs for recessed installation on plasterboard false ceiling + 8 screws.



**Dati fotometrici**  
**Photometric data**

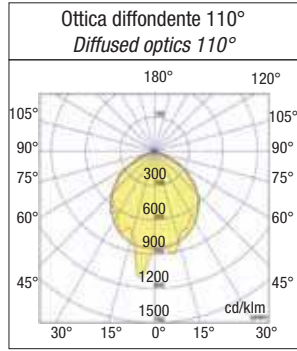

**NEW Milo packaging**

- LED Milo Baklit Q, LED Milo Baklit R, in confezione da 10pcs.  
- 10 pcs packs LED Milo Baklit Q, LED Milo Baklit R.

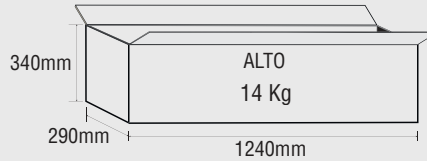
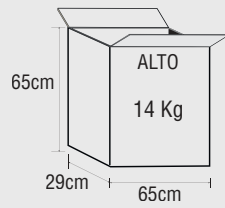

**UGR ≤ 19\***

\* Valori raggiunti per maggior parte di applicazioni per interni. Verificare con vostro lighting designer in fase di progetto la migliore soluzione illuminotecnica per il vostro ufficio.

\* Values achieved for most interior applications. Check with your lighting designer during the design phase for the best lighting solution for your office.

**Accessori non inclusi - Not included accessories**

Cod. 65151LED80CP3



Cod. RP0714CP3

**AUTOTEST**



Cod. 65151LED80CP3  
L240x P59x H40

Kit emergenza 3W - 3h/12% 180÷250 Vac  
180÷250 Vac - 3h/12% - 3W emergency kit

Cod. RP0714CP3 - **AUTOTEST**

L195x P55x H42

Kit emergenza 3W - 3h/12% 180÷250 Vac  
180÷250 Vac - 3h/12% - 3W emergency kit

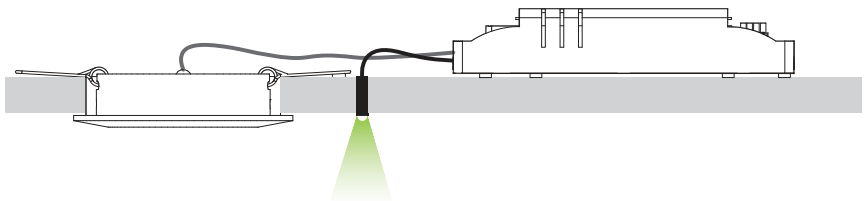

**VANTAGGI EMERGENZA CON AUTOTEST**  
**ADVANTAGES OF EMERGENCY WITH SELF-TEST**

Il modello Autotest segnala eventuali anomalie (attraverso il Led bicolore Rosso-Verde) che possono presentarsi durante il normale funzionamento della batteria e/o circuito di pilotaggio della lampada a cui è collegato l'inverter.

The Autotest model signals any anomalies (through the two-colour Red-Green LED) that may occur during normal operation of the battery and/or piloting circuit of the lamp to which the inverter is connected

Colore LED - LED indication	Stato - Status
Verde fisso - Permanent Green	Batteria carica o in carica - Battery charge or charging
Verde lampeggiante - Flashing Green	Funzione TEST avviata - TEST in progress
Verde lampeggiante lento (1s ON - 1s OFF) Slow flashing green (1s ON - 1s OFF)	TEST di autonomia avviato - Autonomy TEST in progress
Rosso fisso - Permanent Red	Lampada guasta - Lamp failure
Rosso lampeggio veloce (0,1s ON - 0,1s OFF) Fast flashing Red (0,1s ON - 0,1s OFF)	Guasto circuito di ricarica - Charging failure
Lampeggio Rosso lento (1s ON - 1s OFF) Slow flashing Red (1s ON - 1s OFF)	Batteria guasta - Battery failure
Verde e Rosso OFF - Green and Red OFF	Emergenza ON - Emergency ON

**Possibilità di gestione del punto luce centralizzata o con sensori di presenza / luminosità.**  
**Possibility of managing the centralized light point or with presence / brightness sensors.**



cod. **HBTDA** **DALI 2** PUSH



Informazioni prodotto  
Product information

**Sensore di movimento e crepuscolare con Varialuce integrato:**

- è il **software**, è il **hardware** del sistema integrato nell'apparecchio.
- Funzione MASTER e SLAVE.
- Dimmer **DALI** in **Bluetooth 5.0 SIG MESH** funzione ON-OFF, temporizzazione.
- Applicazione ad incasso o plafone.

**Motion and twilight sensor with integrated Dimmer:**

- it is the **software**, the **hardware** of the system integrated into the device.
- MASTER and SLAVE function.
- Dimmer **DALI** in **Bluetooth 5.0 SIG MESH** function, timing.
- Recessed or ceiling-mounted application.



Accessorio per montaggio a plafone  
Ceiling mount accessory

	Lenti incluse nella confezione Lenses included in the package	Rilevamento max (DxH) Max detection (DxH)	Asimmetrica Asymmetric	Per corridoi for corridors
Convessa Convex		10m x 3m		
Piatta Flax		9m x 3m		

## LED Itaca R-C-S

A RICHIESTA  
ON DEMAND

0-10V

DALI 2



Famiglia di apparecchi a LED ad elevato confort visivo con un bassissimo indice di abbagliamento, pensata per aree comuni, corridoi, scale, laboratori, strutture sanitarie, sale riunioni, negozi. Ideale dove è richiesta un'illuminazione con livelli di abbagliamento minimi. Il bassissimo consumo energetico e le contenute temperature garantiscono una lunga durata al prodotto. L'utilizzo della tecnologia LED garantisce una resa luminosa elevata in relazione al consumo di energia, annullando completamente i costi di manutenzione.

**Installazione:** ad incasso in appoggio alla struttura del controsoffitto.

A plafone e a sospensione (con accessori di montaggio **Cod. 31300**).

**Corpo:** in alluminio verniciato (bianco RAL 9003 versione R-C) (grigio RAL9006 versione S).

**Ottica:** dark-light per una riduzione massima dell'abbagliamento.

**Temperatura di colore:** 3000K - 4000K.

**Driver multipotenza** : da ordinare a parte, per modelli ad incasso.

**Driver multipotenza** : incluso: nei modelli a plafone.

Con possibilità di diminuzione della potenza (Lm) tramite DIP. Fattore di potenza  $\geq 0,95$ .

**Conforme alla norma:** EN60598-1, RG0 nessun rischio fotobiologico ai fini della norma EN62471.

**Led:** SMD Mantenimento del flusso luminoso minimo al 80%: L80B20>50.000h.

Prodotto conforme alle direttive:

*Range of high visual comfort LED appliances with a very low glare index, designed for public areas, halls, stairs, laboratories, healthcare facilities, meeting rooms, shops. Ideal where light is required with minimal glare levels. Very low energy consumption and low temperatures guarantee a long product life.*

*LED technology guarantees high light output in relation to energy consumption, completely eliminating maintenance costs.*

**Installation:** recessed set on false ceiling structure.

Ceiling and suspension (with assembly accessories **Code 31300**).

**Body:** in painted aluminum (white RAL 9003 R-C version) (grey RAL9006 S version).

**Optic:** dark-light for maximum glare reduction.

**Color temperature:** 3000K - 4000K.

**Multipower driver** : to be ordered separately for recessed models

**Multipower driver** : included for ceiling models.

With possibility of decreasing power (Lm) by means of DIP switch. Power factor  $\geq 0.95$ .

**According to standard:** EN60598-1, RG0 no photobiological risk for the purposes mentioned in standard EN62471.

**Led:** SMD Maintenance of 80% minimum luminous flux: L80B20>50.000h.

Product compliant with directives:

### LED Itaca R - incasso/recessed

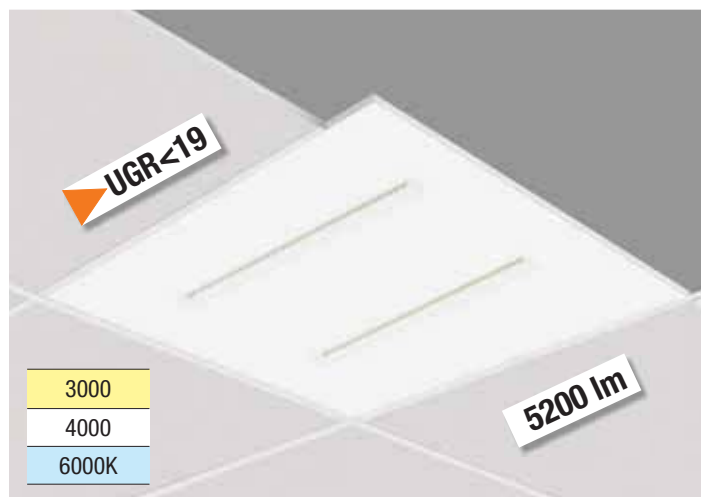

### LED Itaca C - plafone/ceiling

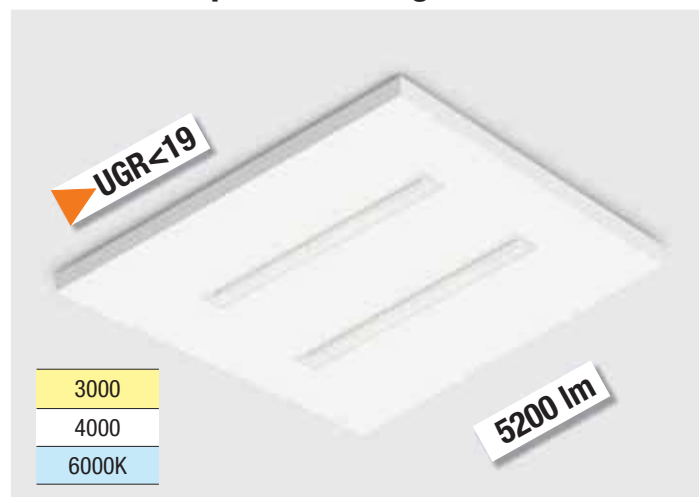



**Accessori non inclusi - Not included accessories**



**Kit emergenza  
Emergency kit**

**Cod. 65151LED80CP3**   
Kit emergenza 3W - 3h/12% 180÷250 Vac  
180÷250 Vac - 3h/12% - 3W emergency kit

**Cod. RP0714CP3 - AUTOTEST**  
Kit emergenza 3W - 3h/12% 180÷250 Vac  
180÷250 Vac - 3h/12% - 3W emergency kit

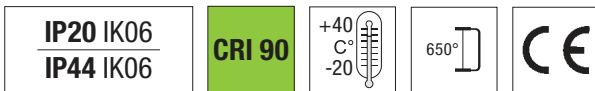

### LED Itaca RR 30X60

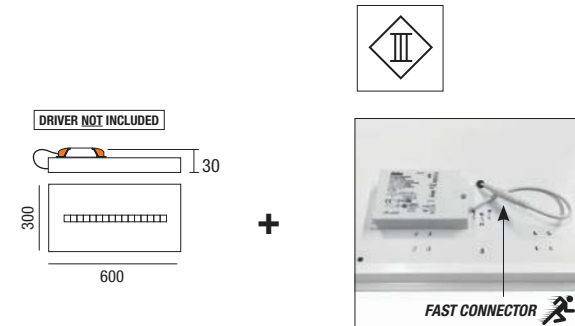

**Driver con connessione rapida**  
*Driver with fast connection.*  
**LED driver multipower**  
**RN9160FAST500**  
**RN9160DAFA500** **DALI 2**

colour	W max	lm output	lm/W	K	Kg	S+L
B	18	max 2600	145	3000	3,20	25888/30603K
B	18	max 2600	145	4000	3,20	25888/3060

### LED Itaca RR 30X120

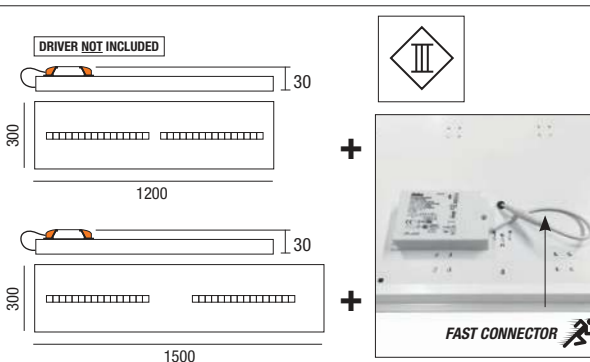
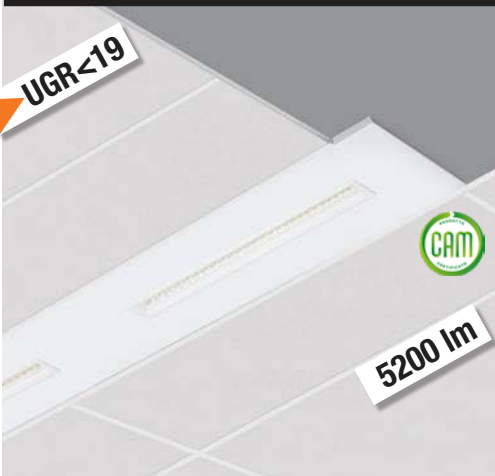

**Driver con connessione rapida**  
*Driver with fast connection.*  
**LED driver multipower**  
**RN9164/FAST**  
**RN8166DAPUFAS** **DALI 2 - PUSH**

colour	W max	lm output	lm/W	K	LxPxH cm	Kg	S+L
B	36	max 5200	145	3000	30x120x5	3,20	25888/301203K
B	36	max 5200	145	4000	30x120x5	3,20	25888/30120
B	36	max 5200	145	4000	30x150x5	3,20	25888/30150

A richiesta: aumentando il numero dei moduli si può arrivare alla potenza di 60W  
*On demand: by increasing the number of modules, the power of 60W can be reached*

### LED Itaca QR 60X60

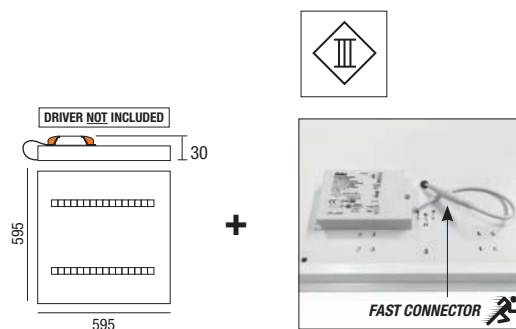
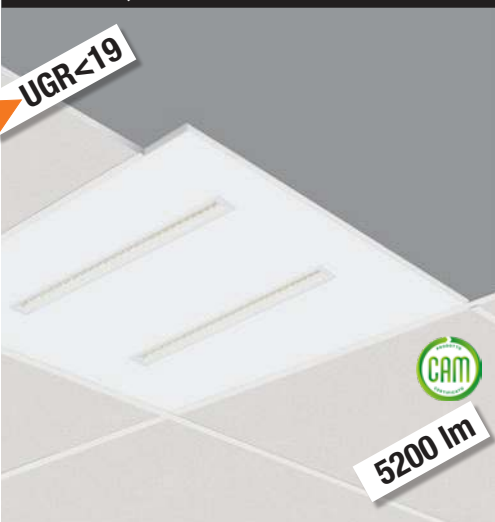

**Driver con connessione rapida**  
*Driver with fast connection.*  
**LED driver multipower**  
**RN9164/FAST**  
**RN8166DAPUFAS** **DALI 2 - PUSH**

colour	W max	lm output	lm/W	K	Kg	S+L
B	36	max 5200	145	3000	3,20	258883K
B	36	max 5200	145	4000	3,20	25888

A richiesta: aumentando il numero dei moduli si può arrivare alla potenza di 60W  
*On demand: by increasing the number of modules, the power of 60W can be reached*

Recessed-ceiling-suspended

LED Itaca RR 60X120

UGR < 19

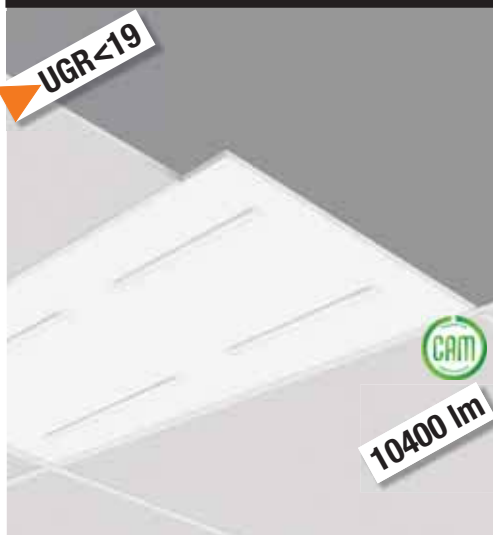

10400 lm

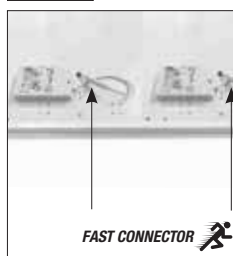
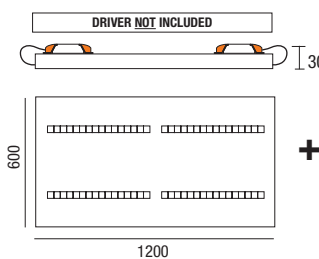

Driver con connessione rapida  
Driver with fast connection.

LED driver multipower  
2x RN9164/FAST  
2x RN8166DAPUFAS DALI 2 - PUSH

colour	W max	lm output	lm/W	K	Kg	S+L
B	72	max 10400	145	3000	6,40	25888/601203K
B	72	max 10400	145	4000	6,40	25888/60120

Connessione rapida  
Rapid connection



Per una più rapida installazione tutti i modelli da incasso sono dotati di cavo con morsetto per collegamento rapido.  
For quicker installation, all the recessed models are equipped of dedicated cable with fast connection terminal.

Dati fotometrici  
Photometric data

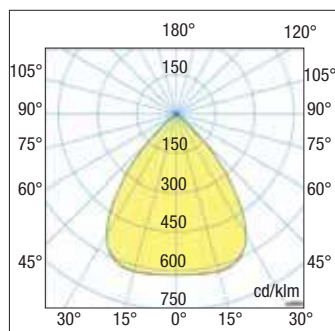

SCEGLI LA GIUSTA CORRENTE PER OTTIMIZZARE IL FLUSSO LUMINOSO NECESSARIO  
CHOOSE THE RIGHT CURRENT TO OPTIMIZE THE NECESSARY LUMINOUS FLUX

Moduli LED LED Modules	Taratura Dip-switch	Potenza Power	Lm Output
	mA	Watt	Lm
	300	11	1544
	400	14	2069
	500	18	2574
	500	18	2574
	700	25	3603
	1000	36	5148
	2x500	36	5148
	2x700	50	7206
	2x1000	72	10296
Taratura standard di fabbrica Driver Standard factory setting			

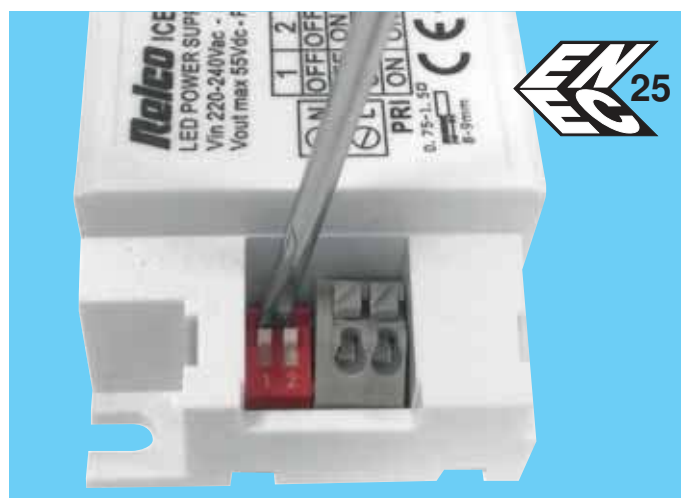

Fornito di dip switch per la selezione della corrente in uscita. Il driver incluso nel prodotto ha una taratura di fabbrica (vedere tabella). Se necessario è possibile diminuire la potenza e di conseguenza i lumen output.

Equipped with dip switch for selecting the current output. The driver included inside the product have a driver standard factory setting (see table). If necessary, it is possible to decrease the power and consequently the lumen output.

## LED Itaca C Plafone - Surface

A RICHIESTA  
ON DEMAND



### LED Itaca C 15W 30X60 H.4cm

UGR<19

2600 lm

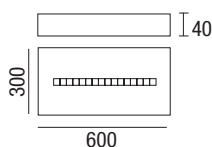

220  
240V

50/60  
Hz



DRIVER INCLUDED  
MULTIPOWER

	colour	W max	lm output	lm/W	K	LxPxH cm	Kg	CELL
	B	18	max 2600	145	3000	30x60x4	3,20	25888/3060C3K
	B	18	max 2600	145	4000	30x60x4	3,20	25888/3060C
<b>DALI 2</b> PUSH	B	18	max 2600	145	4000	30x60x4	3,20	25888/3060CDA

### LED Itaca C 30W 30X120 H.4cm

UGR<19

5200 lm

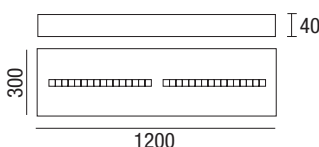

220  
240V

50/60  
Hz



DRIVER INCLUDED  
MULTIPOWER

	colour	W max	lm output	lm/W	K	LxPxH cm	Kg	CELL
	B	36	max 5200	145	3000	30x120x4	3,20	2588830120C3K
	B	36	max 5200	145	4000	30x120x4	3,20	25888/30120C
<b>DALI 2</b> PUSH	B	36	max 5200	145	4000	30x120x4	3,20	25888/30120CD

A richiesta: aumentando il numero dei moduli si può arrivare alla potenza di 60W  
On demand: by increasing the number of modules, the power of 60W can be reached

### LED Itaca C 30W 30X150 H.4cm

UGR<19

5200 lm

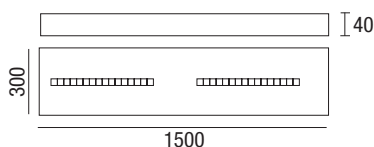

220  
240V

50/60  
Hz



DRIVER INCLUDED  
MULTIPOWER

	colour	W max	lm output	lm/W	K	LxPxH cm	Kg	CELL
	B	36	max 5200	145	3000	30x150x4	3,20	2588830150C3K
	B	36	max 5200	145	4000	30x150x4	3,20	25888/30150C
<b>DALI 2</b> PUSH	B	36	max 5200	145	4000	30x150x4	3,20	25888/30150CD

A richiesta: aumentando il numero dei moduli si può arrivare alla potenza di 60W  
On demand: by increasing the number of modules, the power of 60W can be reached

### LED Itaca C 30W 60X60 H.4cm

UGR<19

5200 lm

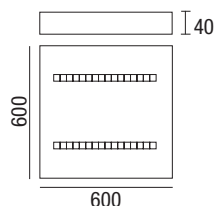

220  
240V

50/60  
Hz



DRIVER INCLUDED  
MULTIPOWER

	colour	W max	lm output	lm/W	K	LxPxH cm	Kg	CELL
	B	36	max 5200	145	3000	60x60x4	3,20	25888C3K
	B	36	max 5200	145	4000	60x60x4	3,20	25888C
<b>DALI 2</b> PUSH	B	36	max 5200	145	4000	60x60x4	3,20	25888CDA

A richiesta: aumentando il numero dei moduli si può arrivare alla potenza di 60W  
On demand: by increasing the number of modules, the power of 60W can be reached

## LED Itaca 60W C 60X120 H.4cm

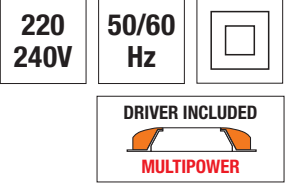
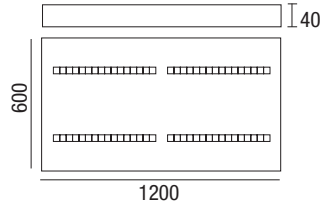
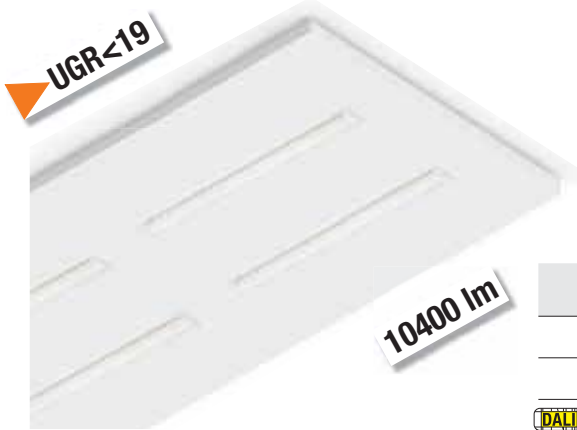

	colour	W max	lm output	lm/W	K	LxPxH cm	Kg	CELL
	B	72	max 10400	130	3000	60x120x4	6,40	2588860120C3K
	B	72	max 10400	130	4000	60x120x4	6,40	25888/60120C
DALI 2 PUSH	B	72	max 10400	130	4000	60x120x4	6,40	25888/60120CD

## LED Itaca S - Suspension

### LED Itaca S 30W 30X120 - 30x150 H.6cm

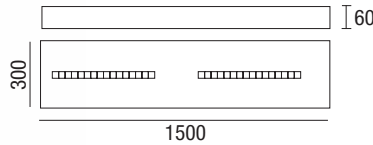

**Installazione:** a sospensione, con accessori di montaggio Cod. 31300.

**Corpo:** in alluminio verniciato grigio RAL9006 (a richiesta bianco RAL 9003).

**Optica:** dark-light per una riduzione massima dell'abbagliamento.

**Temperatura di colore:** 3000K - 4000K.

**Driver multipotenza** : incluso.

**Installation:** rsuspension with assembly accessories Code 31300.

**Body:** in painted aluminum grey RAL9006 (white RAL 9003 on request).

**Optic:** dark-light for maximum glare reduction.

**Color temperature:** 3000K - 4000K.

**Multipower driver** : included.

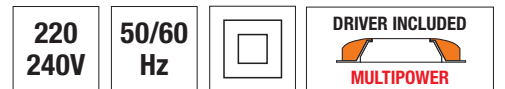

	colour	W max	lm output	lm/W	K	LxPxH cm	Kg	CELL
	G	36	max 5200	145	3000	30x150x6	3,20	25888/30150S3K
	G	36	max 5200	145	4000	30x150x6	3,20	25888/30150S
DALI 2 PUSH	G	36	max 5200	145	4000	30x150x6	3,20	25888/30150SD

A richiesta: aumentando il numero dei moduli si può arrivare alla potenza di 60W  
On demand: by increasing the number of modules, the power of 60W can be reached

### Accessori non inclusi - Not included accessories

#### Cod. ITASFC

Staffa per fila continua.  
Bracket for continuous row.



#### Cod. 31300

Kit per sospensione  
Suspensione Kit



Kit sospensione con cavo 2m che consente di installare LED Itaca S.

Si consiglia l'installazione mantenendo una distanza di almeno 50/60 cm tra soffitto e plafoniera.

*Suspension kit with 2 m cable allows the suspended mounting of the LED Itaca S.*

*We recommend leaving at least 50/60 cm between the ceiling and the lamp when installing it.*

# LED Itaca doghe speciali - Prodotto personalizzato

PRODOTTO PERSONALIZZATO  
CUSTOMIZED PRODUCT

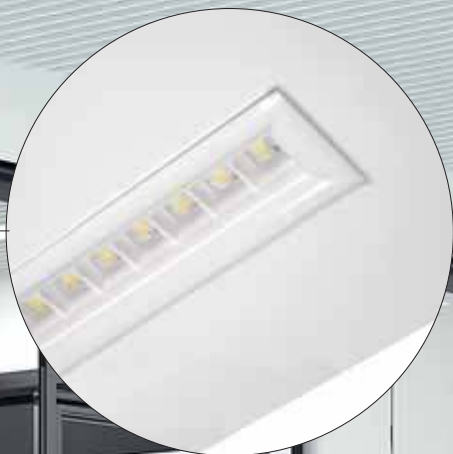

**LED Itaca, cucita su misura.  
LED Itaca, sewn to measure.**

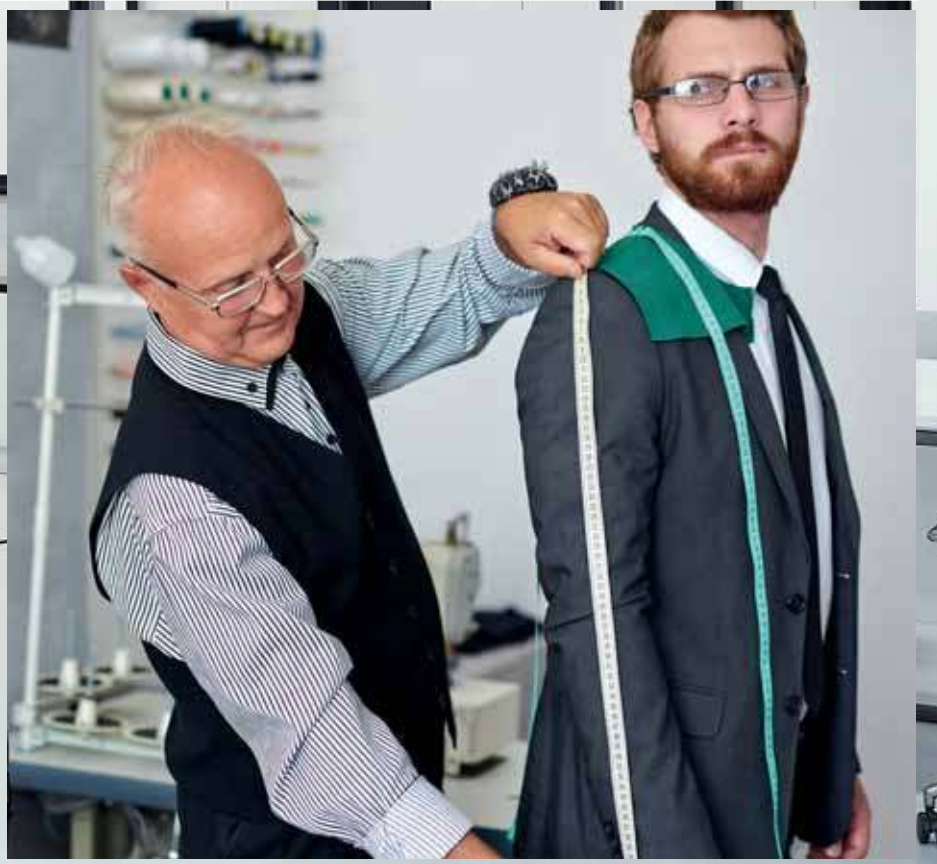

# LED Itaca doghe speciali - Custom product

Apparecchio a LED Custom **UGR<19** per un elevato confort visivo con un bassissimo indice di abbagliamento, in sostituzione retrofit di lampade fluorescenti installate su controsoffitti a doghe. Ideale laddove è richiesta un'illuminazione con livelli di abbagliamento minimi come uffici ed Enti pubblici. Speciale sistema ottico quadrato in cui ogni singolo LED è corredato di lente per aumentare la resa luminosa. Il bassissimo consumo energetico e le contenute temperature garantiscono una lunga durata al prodotto, inoltre l'utilizzo della tecnologia LED annulla completamente i costi di manutenzione.

**Installazione:** retrofit per lampade fluorescenti su doghe, **adatto per cablaggi in Classe I e Classe II.**

**Corpo:** in alluminio verniciato bianco RAL 9003

**Ottica:** bassa luminanza.

**Potenze disponibili:** **min.18W max.60W.**

**Regolazione:** dimmerabile a richiesta.

**Temperatura di colore:** 4000K (Altre temperature di colore a richiesta).

**Driver multipotenza:** incluso. Fattore di potenza  $\geq 0,95$

**Conforme alla norma:** EN60598-1, RG0 nessun rischio fotobiologico ai fini della norma EN62471.

**Led:** Samsung.

**Prodotto conforme alle direttive:** 

*Custom LED fixture with **UGR<19** for high visual comfort with a very low glare index, replacing retrofit of fluorescent lamps installed on strip false ceilings. Ideal where light is required with minimal glare levels such as offices and public buildings. Special square optic system where each individual LED has a lens to increase the light rendering. The very low energy consumption and the limited temperatures guarantee a long life to the product, moreover the use of the LED technology completely eliminates the maintenance costs.*

**Installation:** retrofit for fluorescent lamps on strips, **suitable for Class I and Class II wiring.**

**Body:** in white painted metal RAL 9003

**Optics:** low luminance.

**Available power:** **min.18W max.60W.**

**Adjustment:** dimmable on request.

**Colour temperature:** 4000K (other colour temperatures on request).

**Multipower driver:** included. Power factor  $\geq 0,95$

**Compliant with standard:** EN60598-1, RG0 no photobiological risk for the purposes mentioned in standard EN62471.

**Led:** Samsung.

**Product compliant with directives:** 

A richiesta  
On demand

0-10V



WIRELESS



220-240V

50/60Hz



IP20

IK06

IP44

IK06

LED Itaca doghe

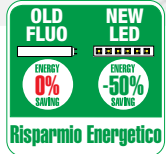

Dimensioni Custom  
a richiesta

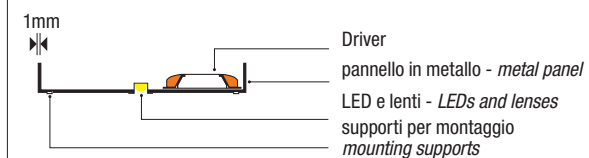

Il seguente articolo è personalizzabile a seconda delle esigenze tecniche ed estetiche del cliente. **Richiedere un preventivo.**

*The following item can be customised according to the customer's technical and aesthetic needs. **Request an estimate.***

## Come sostituire i vecchi apparecchi luminosi in 5 minuti, in modo semplice e immediato. How to replace old light fixtures simply and immediately in five minutes.

Rimuovere la griglia, tubo fluorescente e attacchi (dopo aver scollegato l'impianto esistente dall'alimentazione senza necessità di dover smontare) delle vecchie lampade d'incasso su controsoffitto a doghe e sostituire con il nostro kit **LED Itaca doghe UGR<19**. Inviatoci il campione dello schermo dark light (fig.1) e del corpo lampada, i nostri tecnici customizzeranno la nuova lampada per un relamping immediato. Il sistema di fissaggio del Kit è perfettamente compatibile con la struttura del canale e permette un aggancio rapido e sicuro del corpo illuminante.

*Remove the grid, fluorescent tube and connections (after disconnecting the existing system from the power supply without the need to disassemble) of your old flush mounted lamps on a strip false ceiling and replace with our kit **UGR<19 LED Itaca strips panel**. Send us the sample of the dark light screen (fig.1) or the lamp body, our technicians will customise the new lamp for immediate relamping. The fixing system of the Kit is perfectly compatible with the structure of the channel and allows a quick and safe attachment of the lighting body.*

Rimuovere la griglia  
Remove the grid



Rimuovere la vecchia lampada fluorescente  
Remove the old fluorescent lamp



Agganciare LED Itaca tramite i supporti  
Hook the Itaca LEDs on the supports





WW	NW	CW
▲ 3000K	▲ 4000K	▲ 6000K

Con cambio tonalità mediante selettore integrato posizionato sul corpo lampada è possibile scegliere la temperatura di colore preferita.

*With the integrated selector switch on the lamp body, you can choose your preferred color temperature.*

Serie di apparecchi a LED per ambienti dove sia necessaria una luce diffusa perfettamente omogenea.

**Installazione:** a plafone (con accessori di montaggio inclusi) o sospensione "rigido" solo per diametro 600 o con cavi (con accessori di montaggio non inclusi), ad incasso per tutti i modelli (con accessorio di montaggio non incluso).

**Corpo e telaio:** struttura in Alluminio verniciato, bianco RAL 9003, nero RAL 9005 (altri colori per almeno 50 pcs a richiesta).

**Verniciatura:** di tipo poliestere eseguita a polvere.

**Diffusore:** lastra in policarbonato diffondente.

**Schermo:** in policarbonato opale di spessore 2mm.

**Temperatura colore:** 3000K - 4000K - 6000K

**Led:** mantenimento del flusso luminoso minimo al 80%: L80B20>50.000h.

**Driver:** conforme alle norme EN55015, EN6100-3-2, EN6100-3-3, EN61347-1, EN61347-2-13, EN61547, EN62384.

Fattore di potenza  $\geq 0,95$ .

**Prodotto conforme alle direttive:** 

*Series of LED devices for environments requiring a perfectly evenly diffused light.*

**Installation:** ceiling (with mounting accessories included) or "rigid" suspension only for diameter 600 or with cables (with mounting accessories not included), recessed for all models (with mounting accessory not included).

**Body and frame:** structure in painted aluminum, white RAL 9003, black RAL 9005 (other colors for at least 50 pcs on request).

**Coating:** coated with powdered polyester.

**Diffuser:** sheet in diffusing polycarbonate.

**Shield:** in 2mm thick opal polycarbonate.

**Color temperature:** 3000k - 4000K OR 6000K

**Led:** maintenance of 80% minimum luminous flux: L80B20>50.000h.

**Driver:** in compliant with standards EN55015, EN6100-3-2, EN6100-3-3, EN61347-1, EN61347-2-13, EN61547, EN62384.

Power factor  $\geq 0,95$ .

**Product compliant with directives:** 

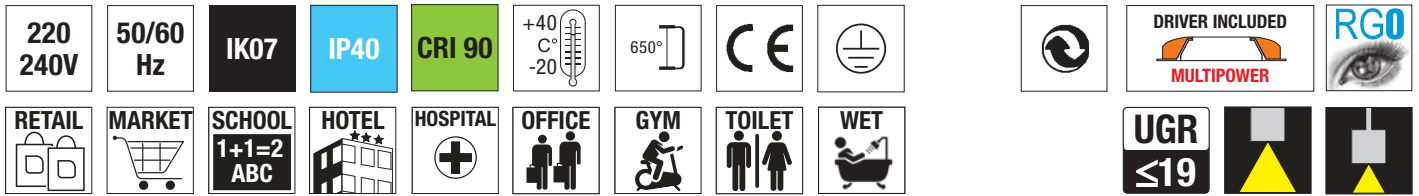

### LED Mercedes 40 S-C-R

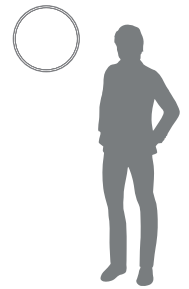
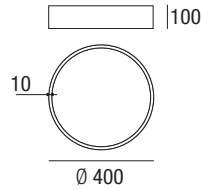

#### Dati fotometrici Photometric data

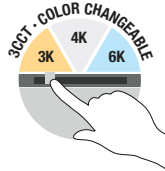
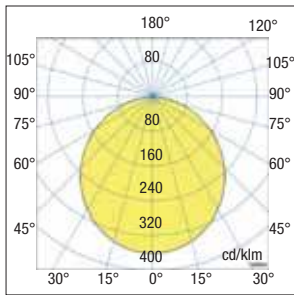

	colour	W max	Lm output	K	pcs	Kg	CELL
	B	30	2184	4000	001	3,50	6024-400/4K
	N	30	2184	4000	001	3,50	6024-400B/4K
	B	30	2184	4000	001	3,50	6024-400/4KDA
	N	30	2184	4000	001	3,50	6024-400B4KDA

### LED Mercedes 40 S-C-R - 3CCT **NEW**

**3CCT**  
SWITCHABLE

	colour	W max	Lm output	K	pcs	Kg	CELL
	B	30	2184	3000 4000 6000	001	3,50	6030-400/3C
	N	30	2184	3000 4000 6000	001	3,50	6030-400B3C
	B	30	2184	3000 4000 6000	001	3,50	6030-400/3CDA
	N	30	2184	3000 4000 6000	001	3,50	6030-400B3CDA

4000 Taratura di fabbrica - Factory settings

### LED Mercedes 60 S-C-R

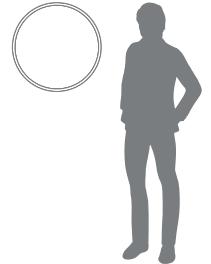
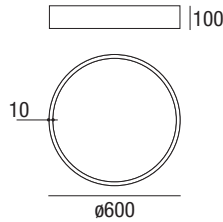

#### Dati fotometrici Photometric data

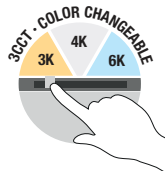
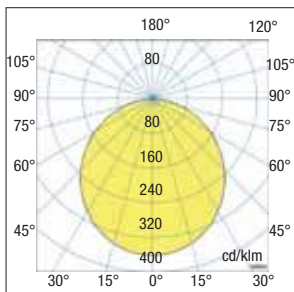

	colour	W max	Lm output	K	pcs	Kg	CELL
	B	45	4095	3000	001	3,50	6048-600
	N	45	4095	3000	001	3,50	6048-600B
	B	45	4095	3000	001	3,50	6048-600DA
	N	45	4095	3000	001	3,50	6048-600BDA
	B	45	4095	4000	001	3,50	6048-600/4K
	N	45	4095	4000	001	3,50	6048-600B/4K
	B	45	4095	4000	001	3,50	6048-600/4KDA
	N	45	4095	4000	001	3,50	6048-600B4KDA

### LED Mercedes 60 S-C-R - 3CCT **NEW**

**3CCT**  
SWITCHABLE

	colour	W max	Lm output	K	pcs	Kg	CELL
	B	45	4095	3000 4000 6000	001	3,50	6045-600/3C
	N	45	4095	3000 4000 6000	001	3,50	6045-600B3C
	B	45	4095	3000 4000 6000	001	3,50	6045-600/3CDA
	N	45	4095	3000 4000 6000	001	3,50	6045-600B3CDA

4000 Taratura di fabbrica - Factory settings

## LED Mercedes 80 S-C-R

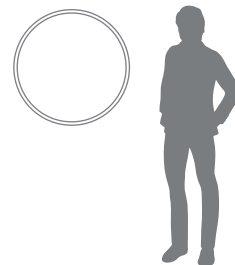
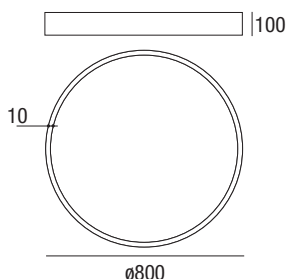

	colour	W max	Lm output	K	pcs	Kg	CELL
	B	80	7280	3000	001	3,50	6048-800
	N	80	7280	3000	001	3,50	6048-800B
<b>DALI 2 PUSH</b>	B	80	7280	3000	001	3,50	6048-800DA
<b>DALI 2 PUSH</b>	N	80	7280	3000	001	3,50	6048-800BDA
	B	80	7280	4000	001	3,50	6048-800/4K
	N	80	7280	4000	001	3,50	6048-800B/4K
<b>DALI 2 PUSH</b>	B	80	7280	4000	001	3,50	6048-800/4KDA
<b>DALI 2 PUSH</b>	N	80	7280	4000	001	3,50	6048-800B4KDA

### Dati fotometrici Photometric data

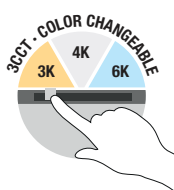
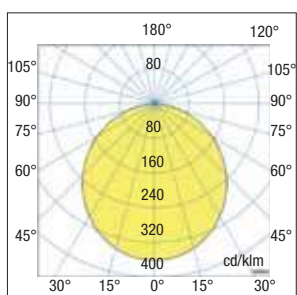

## LED Mercedes 80 S-C-R - 3CCT **NEW**

**3CCT**  
SWITCHABLE

	colour	W max	Lm output	K	pcs	Kg	CELL
	B	80	7280	3000	4000	6000	001 3,50 6080-800/3C
	N	80	7280	3000	4000	6000	001 3,50 6080-800B3C
<b>DALI 2 PUSH</b>	B	80	7280	3000	4000	6000	001 3,50 6080-800/3CDA
<b>DALI 2 PUSH</b>	N	80	7280	3000	4000	6000	001 3,50 6080-800B3CDA

4000 Taratura di fabbrica - Factory settings

## LED Mercedes 120 S-C-R

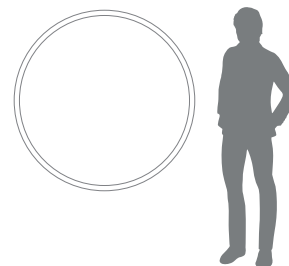
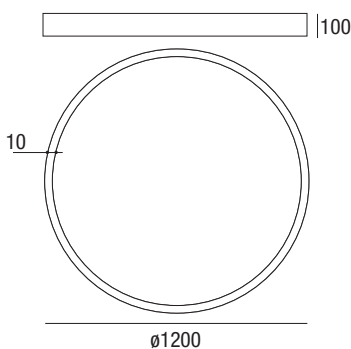

## LED Mercedes 120 S-C-R - 3CCT **NEW**

**3CCT**  
SWITCHABLE

	colour	W max	Lm output	K	pcs	Kg	CELL
	B	120	10900	3000	4000	6000	001 15,50 6048-1200/3C
	N	120	10900	3000	4000	6000	001 15,50 6048-1200B3C
<b>DALI 2 PUSH</b>	B	120	10900	3000	4000	6000	001 15,50 6048-1200/3CDA
<b>DALI 2 PUSH</b>	N	120	10900	3000	4000	6000	001 15,50 6048-1200B3CDA

### Dati fotometrici Photometric data

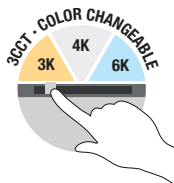
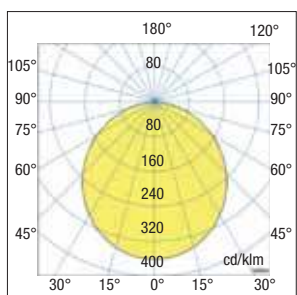

## DALI 2 PUSH

### Mercedes Dimmerabile da pulsante a muro (NON-FORNITO)

#### Mercedes Dimmable from PUSH-button (NOT SUPPLIED)

Con DALI 2 PUSH si possono creare sistemi luminosi che possono essere accesi, spenti e dimmerati in modo semplice, grazie all'utilizzo di pulsanti standard per la gestione della tensione di rete al fine di regolare il flusso luminoso. Una breve pressione del pulsante accende o spegne i driver collegati, invece tenendo premuto il pulsante più a lungo si effettuerà la dimmerazione dei driver collegati.

With DALI 2 PUSH it is possible to create lighting systems that can be switched on, off and dimmed in a simple way, thanks to the use of standard buttons for managing the mains voltage in order to regulate the luminous flux. A short press of the button turns the connected drivers on or off, while keeping the button pressed for longer will dim the connected drivers.

#### Esempio applicativo - Application example

È possibile sincronizzare massimo 5 Drivers.  
it is possible to synchronize maximum 5 drivers.

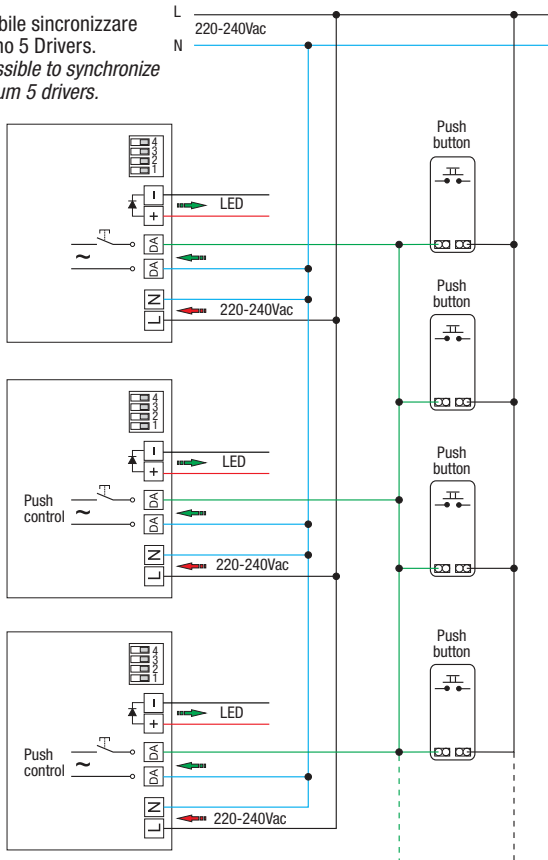

### Mercedes doppia emissione (a richiesta)

#### Mercedes double emission (on demand)

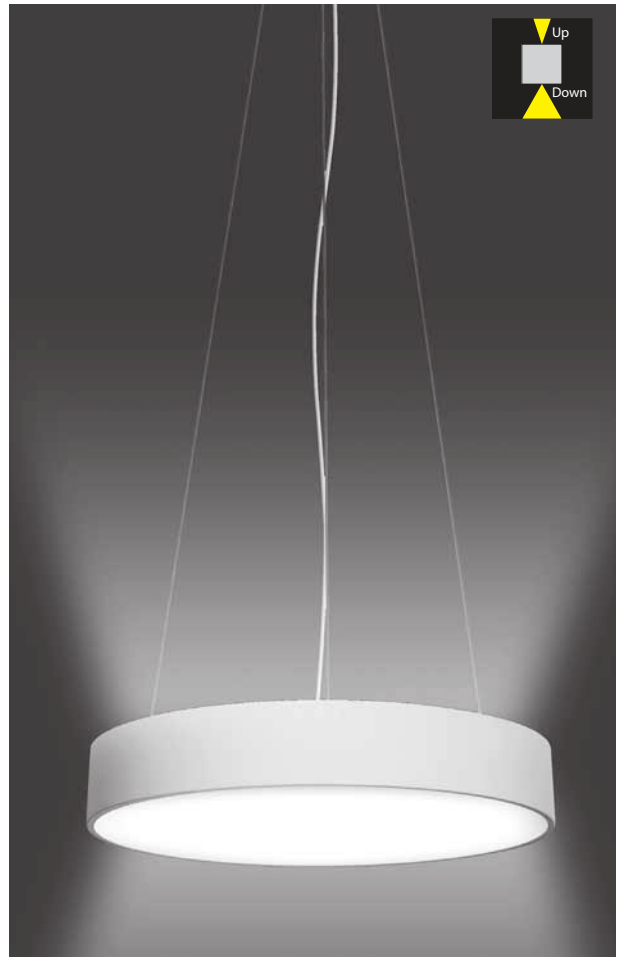

#### MERCEDES Ø400 - Ø600 - Ø800 con doppia emissione

A richiesta per LED Mercedes Ø400 - Ø600 - Ø800 doppia emissione con sovrapprezzo del 50% rispetto al listino.

#### MERCEDES Ø400 - Ø600 - Ø800 with double emission

On request for LED Mercedes Ø400 Ø600 - Ø800 double emission with a 50% surcharge on the price list.

#### Tabella di scelta potenza driver LED - LED Power supply table choice

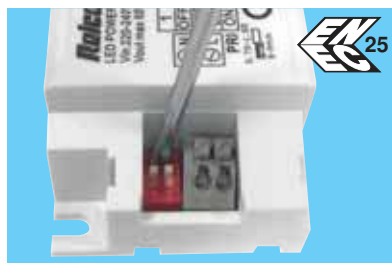

Forniti di dip switch per la selezione della corrente in uscita. Il driver incluso nel prodotto ha una taratura di fabbrica (vedere tabella). Se necessario è possibile diminuire la potenza nei modelli Ø600 e Ø800, nel modello Ø400 è possibile diminuire o aumentare la potenza e di conseguenza il lumen output.

Equipped with dip switch for selecting the current output. The driver included inside the product has a driver standard factory setting (see table). If necessary, it is possible to decrease the power in the Ø600 and Ø800 models, in the Ø400 model it is possible to decrease or increase the power and consequently the lumen output.

#### Mercedes Ø400

Taratura Dip-switch	Potenza Power	Lm Output
mA	Watt	Lm
500	20	1820
600	24	2184
650	27	2457
700	30	2730

Taratura standard di fabbrica  
Driver Standard factory setting

#### Mercedes Ø600

Taratura Dip-switch	Potenza Power	Lm Output
mA	Watt	Lm
800	35	3185
900	38	3458
950	40	3640
1050	45	4095

Taratura standard di fabbrica  
Driver Standard factory setting

#### Mercedes Ø800

Taratura Dip-switch	Potenza Power	Lm Output
mA	Watt	Lm
800	55	5000
900	65	5900
950	70	6370
1050	80	7280

Taratura standard di fabbrica  
Driver Standard factory setting

**Versione C a plafone:** accessori per montaggio a plafone inclusi.  
**Ceiling C version:** ceiling mounting accessories included.

**B** Bianco RAL 9003 - di serie/ standard



**N** Nero RAL 9005



**Accessorio incasso non incluso**  
**Recessed accessory not included**

**B** Cod. 6024-400RW - Ø400  
 Cod. 6048-600RW - Ø600  
 Cod. 6024-800RW - Ø800  
 Cod. 6048-1200RW - Ø1200

**N** Cod. 6024-400RB - Ø400  
 Cod. 6048-600RB - Ø600  
 Cod. 6024-800RB - Ø800  
 Cod. 6048-1200RB - Ø1200

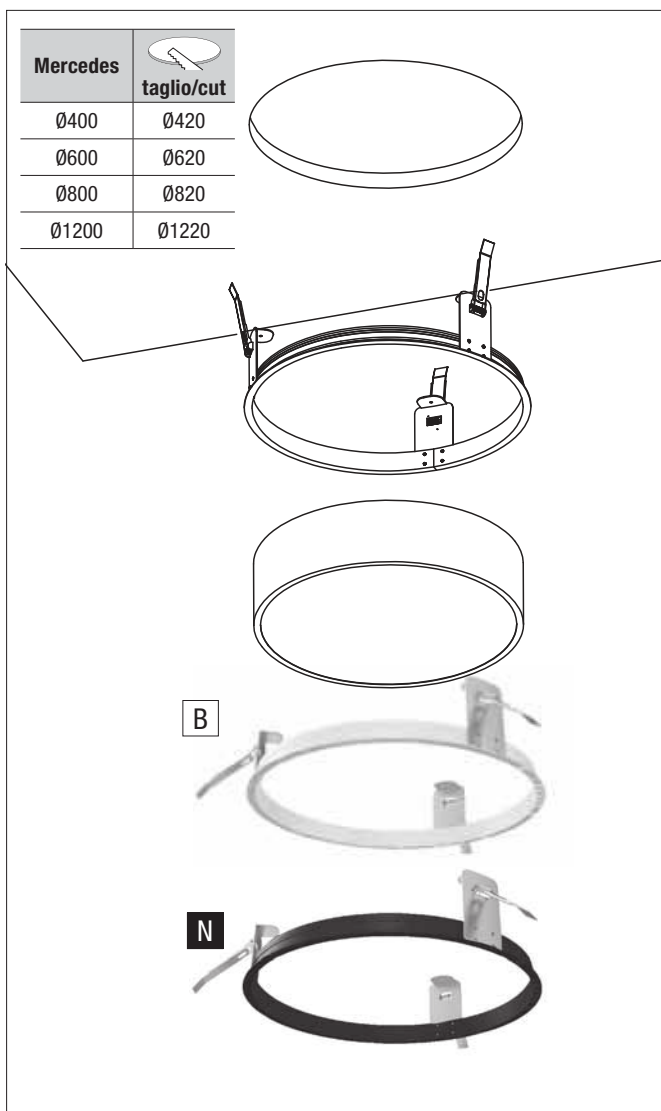

Mercedes	taglio/cut
Ø400	Ø420
Ø600	Ø620
Ø800	Ø820
Ø1200	Ø1220

**Accessorio plafone non incluso**  
**Ceiling accessory not included**

**Cod. 6024-SR**  
 Ø400 - Ø600



**Cod. 8024-SR**  
 Ø800



**Staffa rigida a richiesta**  
**Rigid ceiling staff on request**

Staffa rigida a plafone per Mercedes Ø400 Ø600 - Ø800 sezionabile in 3 moduli da 30 cm.

Ceiling mounted for Mercedes Ø400 - Ø600 Ø800 rigid bracket sectionable into 3 modules of 30 cm.

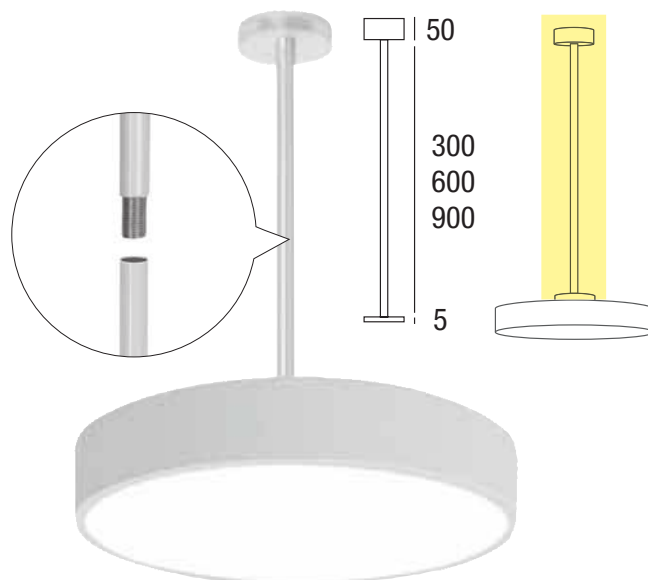

**Cornice da incasso per Mercedes a richiesta**  
**Recessed frame for Mercedes on request**

Cornice disponibile in due colorazioni, bianco RAL 9003 e nero RAL 9005.  
 Frame available in two colours, white RAL 9003 and black RAL 9005.



**B**  
Weiß / Blanc  
RAL 9003



**Cod. 6024-S (400/800/600)**  
**Cod. 6024-S-1200**  
Kit sospensione 1,5 metri colore bianco(2X0,75mm).  
*Suspension Kit white color 1,5 meters.*

**Cod. 6024-5m-S**  
**(cavo bianco/ white cable)**  
Kit sospensione 5 metri, colore bianco (2X0,75mm).  
*Suspension kit 5 meters, white color (2X0,75mm).*



**N**  
Schwarz/ Noir  
RAL 9005



**Cod. 6024-B-S (400/800/600)**  
**Cod. 6024-B-S-1200**  
Kit sospensione 1,5 metri colore nero.  
*Suspension Kit black color 1,5 meters.*

**Cod. Cod. 6024-5m-S-B**  
**(cavo nero/ black cable)**  
Kit sospensione 5 metri, colore nero (2X0,75mm).  
*Suspension kit 5 meters, black color (2X0,75mm).*

**MERCEDES VERSIONE** 

Kit sospensione per LED Mercedes 40, 60, 80 e 120 va modificato utilizzando un cavo a 5 poli (non fornito).

**MERCEDES**  **VERSION**

*Suspension kit for LED Mercedes 40, 60, 80 and 120 must be modified using a 5-pole cable (Not supplied).*

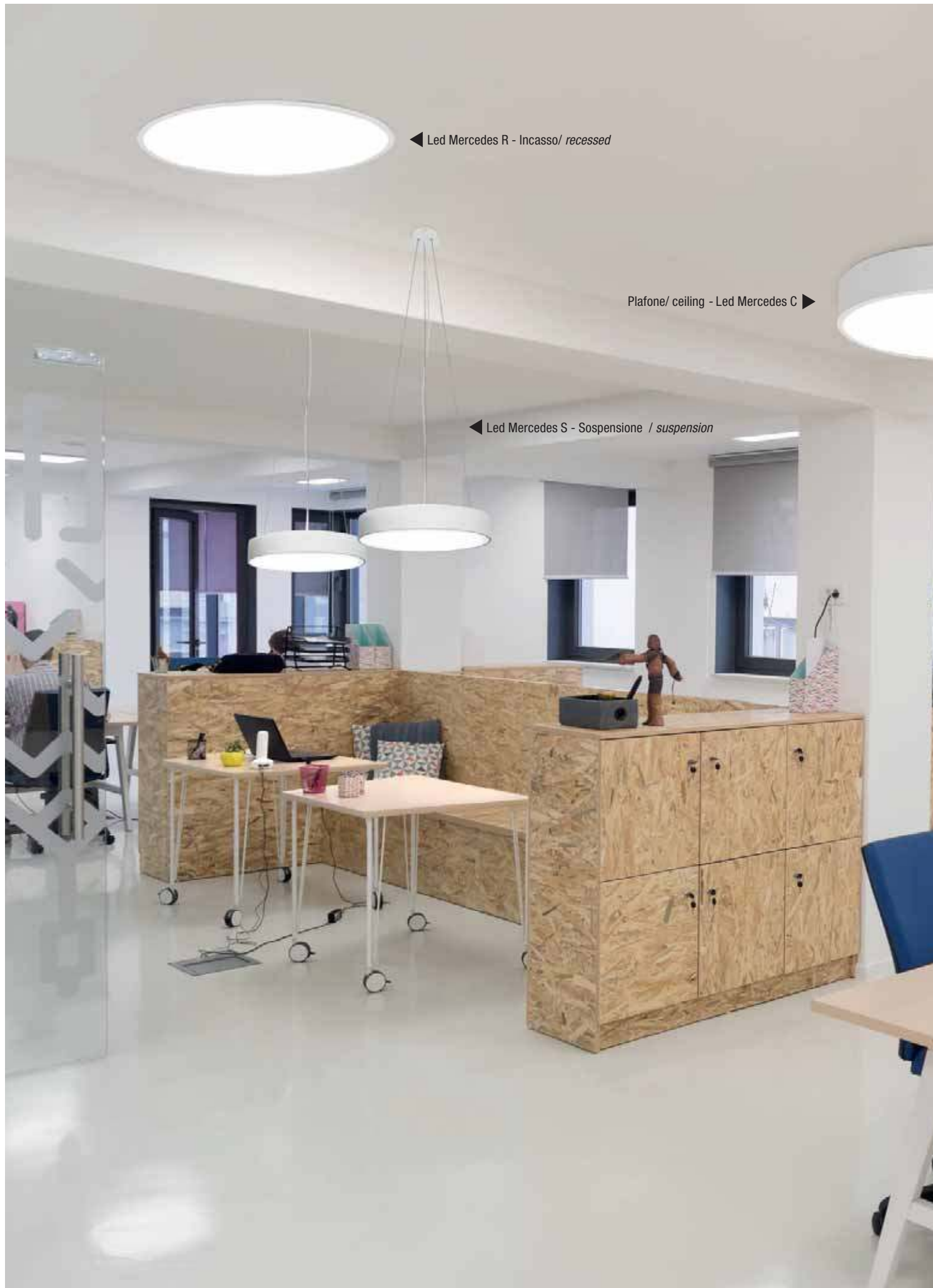

◀ Led Mercedes R - Incasso/ recessed

Plafone/ ceiling - Led Mercedes C ▶

◀ Led Mercedes S - Sospensione / suspension



## LED Mercedes Floor Up & Down



**Piantana a LED dimmerabile a 3 step** ad emissione diretta e indiretta ad alta resa cromatica, per aree comuni, uffici, sale riunioni. Ideale in ambienti dove sia necessaria una luce diffusa perfettamente omogenea e per spazi di lavoro in cui è necessario un maggiore controllo dell'abbagliamento, grazie allo schermo diffusore microprismato, abbinato ad un film diffondente, consente un'ottimale diffusione della componente diretta della luce e un controllo della luminanza UGR<10.

I led per l'emissione down light e up light sono disposti nel perimetro.

**Installazione:** da terra. Il sistema è completo di cavi di alimentazione di lunghezza 2000 mm.

**Corpo e telaio:** profilo perimetrale in alluminio estruso anodizzato, verniciati con polvere termoisolante poliestere.

**Verniciatura:** di tipo poliestere eseguita a polvere. Colore bianco RAL 9010.

**Ottica:** diffondente. Composta da lastra in tecnopolimero (PMMA).

**Schermo:** schermo diffusore PMMA.

**UGR:** Conforme alla norma EN 12464-1 - ≤10.

**Temperatura colore:** standard 4000K.

**Conforme alla norma:** EN60598-1, RG0 nessun rischio fotobiologico ai fini della norma EN62471.

**Led:** mantenimento del flusso luminoso minimo al 80%: L80B20>50.000h.

**Driver:** multipotenza . Fattore di potenza ≥0,95.

**3 Step dimmable LED floor lamp** with direct and indirect emission with high colour rendering, for public areas, offices, meeting rooms. Ideal for rooms requiring perfectly evenly diffused light and for workspaces which need greater glare control, thanks to the microprismatic diffuser screen, coupled to an internal diffuser film screen, for optimal diffusion of the direct light component and luminance control UGR<10.

LEDs for down light and up light emission are set up in the perimeter.

**Installation:** on floor. The system includes 2000 mm long power cables.

**Body and frame:** perimeter profile in anodised extruded aluminium, coated with thermosetting polyester powder.

**Painting:** powder polyester coating. White RAL 9010.

**Optics:** diffusing. Consisting of techno-polymer sheet (PMMA).

**Screen:** PMMA diffuser screen.

**UGR:** Complies with standard EN 12464-1 - ≤10.

**Colour temperature:** standard 4000K.

**Compliant with standard:** EN60598-1, RG0 no photobiological risk for the purposes mentioned in standard EN62471.

**LED:** maintenance of 80% minimum luminous flux: L80B20>50.000h.

**Driver:** multipower . Power factor ≥0.95.

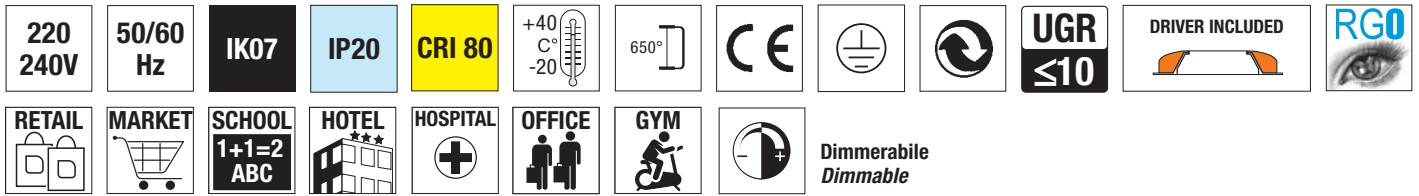

**LED Mercedes floor Up & Down**

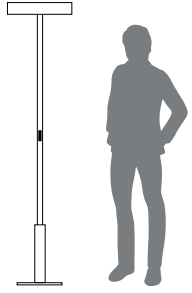
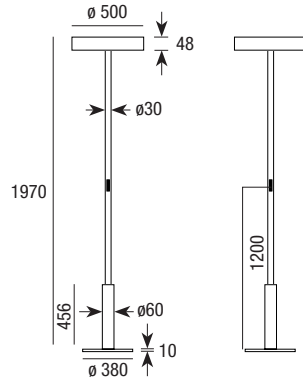
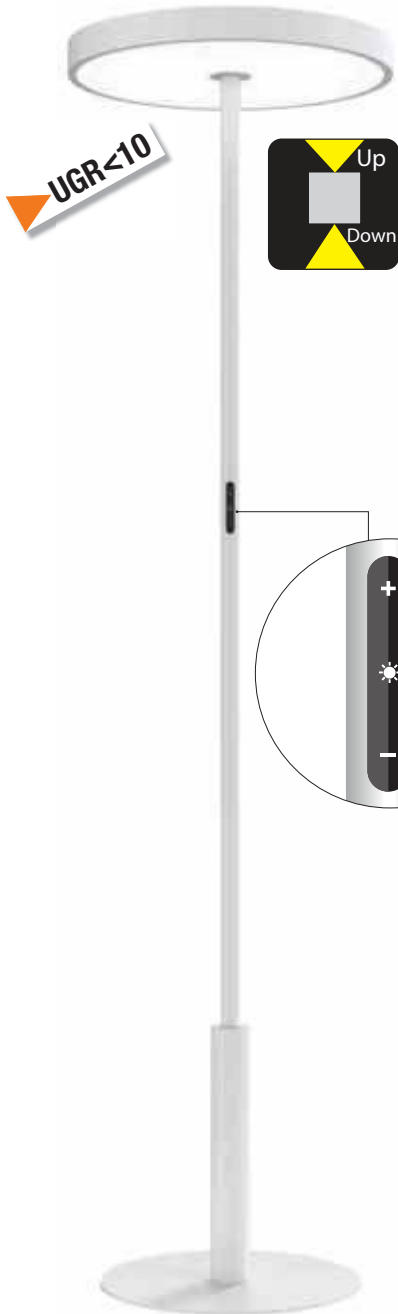

colour	W max	Lm output	lm/W	K	pcs	Kg	CELL
B	↑ 40 ↓ 40	↑ 4800 ↓ 4800	120	4000	001	13,9	RLRF1904506

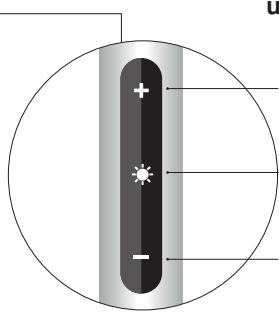

Regolazione continua +, pressione prolungata  
*Long pressing to dimming +*

Interruttore ON-OFF:  
 1. ON: si accende e manterrà automaticamente la stessa luce dello stato precedente  
 2. OFF: spegne la luce

ON-OFF switch:  
 1. ON: Turn on and will keep light same as previous status automatically  
 2. OFF: Turn off the light

Regolazione continua -, pressione prolungata  
*Long pressing to dimming -*

**Dati fotometrici**  
**Photometric data**

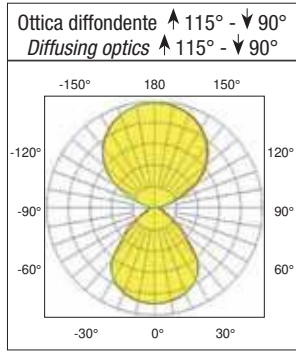

Floor up & down

## LED Zante Floor Up & Down



**Piantana a LED dimmerabile** ad emissione diretta e indiretta neutral white 4000K ad alta resa cromatica, per aree comuni, uffici, sale riunioni, negozi. Ideale in ambienti dove sia necessaria una luce diffusa perfettamente omogenea e per spazi di lavoro in cui è necessario un maggiore controllo dell'abbagliamento, grazie allo schermo diffusore microprismato, abbinato ad uno schermo interno e ad un film diffondente, consente un'ottimale diffusione della componente diretta della luce e un controllo della luminanza UGR<19.

I led per l'emissione down light e up light sono disposti nel perimetro.

**Installazione:** da terra. Il sistema è completo di cavi di alimentazione di lunghezza 2000 mm.

**Corpo e telaio:** profilo perimetrale in alluminio estruso anodizzato, verniciati con polvere termoindurente poliesteri.

**Verniciatura:** di tipo poliesteri eseguita a polvere. Colore bianco RAL 9010.

**Ottica:** diffondente. Composta da lastra in tecnopolimero (PMMA).

**Schermo:** schermo diffusore microprismato.

**UGR:** Conforme alla norma EN 12464-1 -  $\leq 19$ .

**Temperatura colore:** standard 4000K.

**Conforme alla norma:** EN60598-1, RG0 nessun rischio fotobiologico ai fini della norma EN62471.

**Led:** mantenimento del flusso luminoso minimo al 80%: L80B20>50.000h.

**Driver:** multipotenza . Fattore di potenza  $\geq 0,95$ .

***Dimmable LED floor lamp** with direct and indirect emission, neutral white 4000K with high colour rendering, for public areas, offices, meeting rooms, shops. Ideal for rooms requiring perfectly evenly diffused light and for workspaces which need greater glare control, thanks to the micro-prismatic diffuser screen, coupled to an internal diffuser film screen, for optimal diffusion of the direct light component and luminance control UGR<19.*

*LEDs for down light and up light emission are set up in the perimeter.*

***Installation:** on floor. The system includes 2000 mm long power cables.*

***Body and frame:** perimeter profile in anodised extruded aluminium, coated with thermosetting polyester powder.*

***Painting:** powder polyester coating. White RAL 9010.*

***Optics:** diffusing. Consisting of techno-polymer sheet (PMMA).*

***Screen:** microprismatic diffuser screen.*

***UGR:** Complies with standard EN 12464-1 -  $\leq 19$ .*

***Colour temperature:** standard 4000K.*

***Compliant with standard:** EN60598-1, RG0 no photobiological risk for the purposes mentioned in standard EN62471.*

***LED:** maintenance of 80% minimum luminous flux: L80B20>50.000h.*

***Driver:** multipower . Power factor  $\geq 0,95$ .*

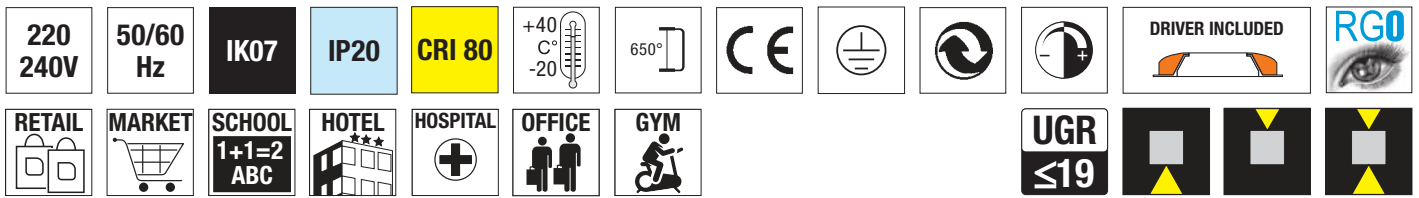

**LED Zante Floor Up & Down**

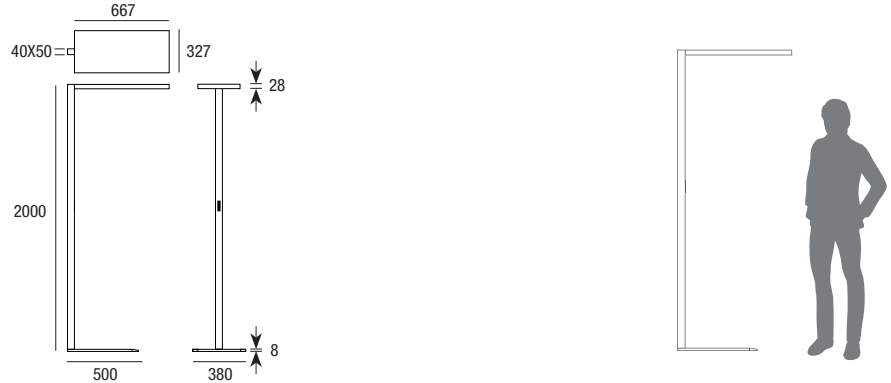

colour	W max	Lm output	lm/W	K	pcs	Kg	CELL
[B]	55	max 6.600	120	4000	001	13,9	25930/FLOOR

**Dati fotometrici  
Photometric data**

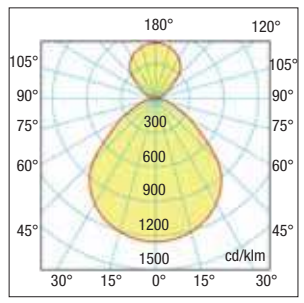

*illuminazione solo sotto  
Lighting only below*



*illuminazione solo sopra  
Lighting only above*



*illuminazione sopra e sotto  
Lighting above and below*



Diffusore  
microprismatizzato 0,75mm  
*Microprismatic diffuser  
0.75mm*



Tastierino push per la  
scelta e la regolazione  
della sorgente luminosa.  
*Button keypad to select  
and regulation light  
source .*



**Floor up & down**



Piantana a LED a luce diretta e indiretta, dimmerabile DALI e Dynamic Tunable White ad alta resa cromatica. Perfetta per tutte le postazioni di lavoro dove sia presente un videoterminale e in cui sia necessario un controllo preciso dell'abbagliamento. Grazie alle microttiche la luce diretta raggiunge valori UGR < 14. La luce indiretta, invece, aumenta il comfort della stanza illuminata, per effetto della riduzione delle zone d'ombra.

**Installazione:** da terra. Il sistema è completo di cavi di alimentazione di lunghezza 2000 mm.

**Corpo e telaio:** Lamiera preverniciata.

**Verniciatura:** di tipo poliestere eseguita a polvere, Grigio scuro goffrato.

**Viteria:** acciaio.

**Ottica:** diffondente 75°. Composta da lastra in tecnopolimero (PMMA).

**Schermo:** alluminio specchiato.

**UGR:** Conforme alla norma EN 12464-1 - ≤14.

**Temperatura colore:** standard 4000K.

**Conforme alla norma:** EN60598-1, RG0 nessun rischio fotobiologico ai fini della norma EN62471.

**Led:** SMD2835 mantenimento del flusso luminoso minimo al 80%: L80B20>50.000h.

**Driver:** DALI INCLUSO . Fattore di potenza ≥0,95.

**Controller Wireless:** CASAMBI

*LED floor lamp with direct and indirect light, dimmable DALI and Dynamic Tunable White with high color rendering. Perfect for all workstations where there is a video terminal and where precise glare control is necessary. Thanks to the microoptics, direct light reaches UGR values < 14. Indirect light, on the other hand, increases the comfort of the illuminated room, due to the reduction of shadow areas.*

**Installation:** on floor. The system includes 2000 mm long power cables.

**Body and frame:** Pre-painted sheet.

**Painting:** powder polyester coating, embossed dark grey.

**Screws:** steel.

**Optics:** diffusing 75°. Consisting of techno-polymer sheet (PMMA).

**Screen:** mirrored aluminium.

**UGR:** Complies with standard EN 12464-1 - ≤14.

**Colour temperature:** standard 4000K.

**Compliant with standard:** EN60598-1, RG0 no photobiological risk for the purposes mentioned in standard EN62471.

**LED:** SMD2835 maintenance of 80% minimum luminous flux: L80B20>50.000h.

**Driver:** DALI INCLUDED . Power factor ≥0.95.

**Controller Wireless:** CASAMBI

220 240V	50/60 Hz	IK07	IP20	CRI>90	+40 C -20	650°	CE				DRIVER INCLUDED	RG0
SCHOOL 1+1=2 ABC	HOSPITAL	HOTEL	OFFICE					CASAMBI	UGR ≤14			

**LED L elle Up & Down**

Lm ↑	80%	UP ↑	Opal optic
Lm ↓	20%	DOWN ↓	Darklite optic

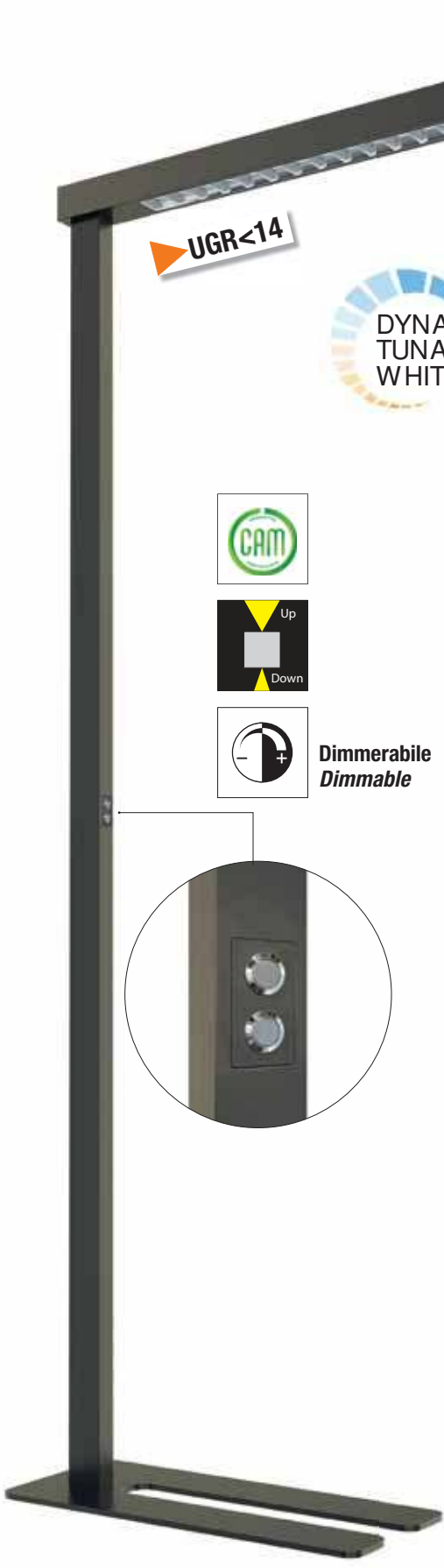

DYNAMIC  
TUNABLE  
WHITE

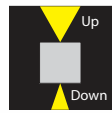

Dimmerabile  
Dimmable

colour	W max	Lm output	lm/W	K	pcs	Kg	CELL
BR	80 180-220	max 8.800	110	3000 5700	001	13,5	ELLEGRAY

**Dati fotometrici  
Photometric data**

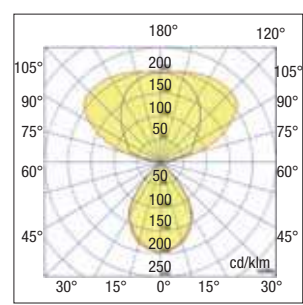

illuminazione solo sotto  
Lighting only below



illuminazione solo sopra  
Lighting only above



illuminazione sopra e sotto  
Lighting above and below

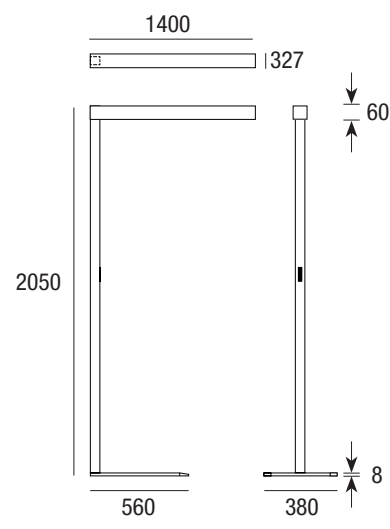

Floor up & down

# LED Giorgia Floor Up



**Piantana a LED dimmerabile a 3 step** ad emissione indiretta ad alta resa cromatica, per aree comuni, uffici, sale riunioni, negozi. Ideale in ambienti dove sia necessaria una luce diffusa perfettamente omogenea.

**Installazione:** da terra.

Il sistema è completo di cavi di alimentazione di lunghezza 2000 mm. e spina Shuko.

**Corpo e telaio:** profilo perimetrale in alluminio estruso anodizzato, verniciati con polvere termoindurente poliestere.

**Verniciatura:** di tipo poliestere eseguita a polvere. Colore bianco RAL 9010.

**Ottica:** diffondente.

**Schermo:** schermo diffusore microprismato.

**UGR:** Conforme alla norma EN 12464-1 -  $\leq 10$ .

**Temperatura colore:** 3000K.

**Conforme alla norma:** EN60598-1, RG0 nessun rischio fotobiologico ai fini della norma EN62471.

**Led:** mantenimento del flusso luminoso minimo al 80%: L80B20>50.000h.

**Driver:** multipotenza . Fattore di potenza  $\geq 0,95$ .

**3 step dimmable LED floor lamp** with indirect emission with high colour rendering, for public areas, offices, meeting rooms, shops. Ideal for rooms requiring perfectly evenly diffused light.

LEDs for down light and up light emission are set up in the perimeter.

**Installation:** on floor. The system includes 2000 mm long power cables, with Shuko plug

**Body and frame:** perimeter profile in anodised extruded aluminium, coated with thermosetting polyester powder.

**Painting:** powder polyester coating. White RAL 9010.

**Optics:** diffusing.

**Screen:** microprismatic diffuser screen.

**UGR:** Complies with standard EN 12464-1 -  $\leq 10$ .

**Colour temperature:** 3000K.

**Compliant with standard:** EN60598-1, RG0 no photobiological risk for the purposes mentioned in standard EN62471.

**LED:** maintenance of 80% minimum luminous flux: L80B20>50.000h.

**Driver:** multipower . Power factor  $\geq 0.95$ .

220 240V	50/60 Hz	IK07	IP20	CRI 80	+40 C° -20	650°	CE			UGR ≤10	DRIVER INCLUDED	RG0
RETAIL	MARKET	SCHOOL 1+1=2 ABC	HOTEL	HOSPITAL	OFFICE	GYM				Dimmbar Gradable		

## LED Georgia Floor Up

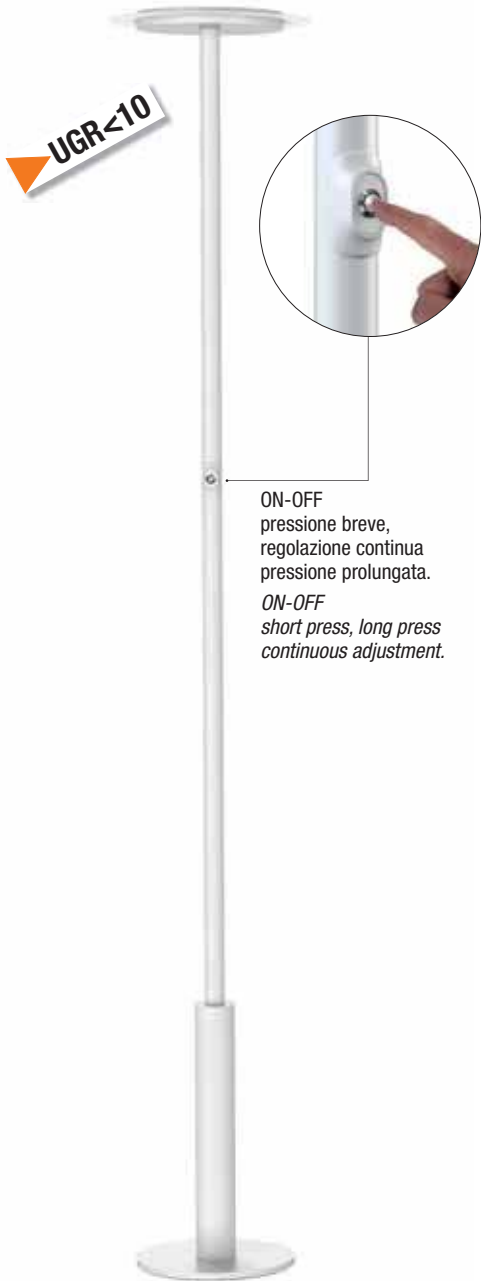

ON-OFF  
pressione breve,  
regolazione continua  
pressione prolungata.  
ON-OFF  
short press, long press  
continuous adjustment.

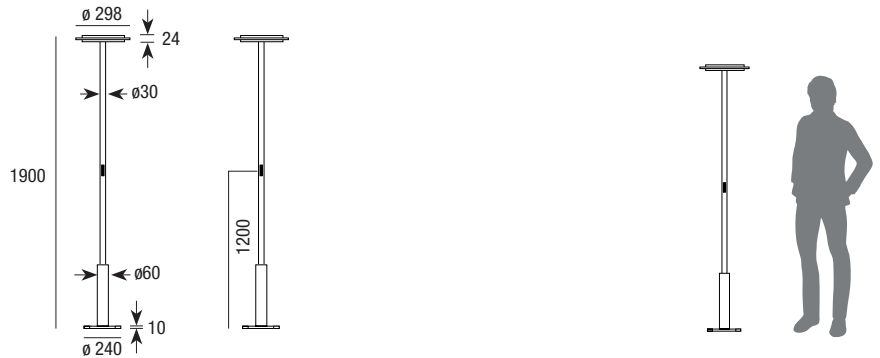

colour	W max	Lm output	lm/W	K	pcs	Kg	CELL
B	45	max 5.400	120	3000	001	13,9	RLSF1904506

### Dati fotometrici Photometric data

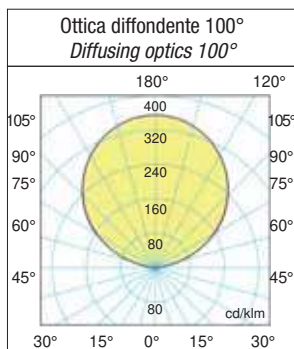

## LED Unica S-C

Apparecchio singolo e fila continua  
*Single devices and continuous line*

È un oggetto brillante che valorizza gli ambienti di lavoro e di comunicazione sia con l'effetto di luce che con l'estetica. Ideale per lavorare ma anche per rilassarsi e disporre sempre di un'atmosfera piacevole.

LED Unica è decisamente versatile nell'impiego: uffici, istituti scolastici sono le due applicazioni più tipiche in cui si rivela la soluzione ideale per economicità e non solo in termini di luce ma anche di manutenzione.

**Installazione:** sospensione (accessori non inclusi), plafone (con accessori di montaggio inclusi).

**Corpo e telaio:** struttura in lamiera di acciaio.

**Verniciatura:** di tipo poliestere eseguita a polvere. Colore bianco RAL 9010.

**Diffusore:** lastra in policarbonato diffondente.

**Schermo:** in policarbonato opale di spessore 2mm.

**Temperatura colore:** 3000 e 4000K.

**Led:** mantenimento del flusso luminoso minimo al 80%: L80B20>50.000h.

**Driver:** conforme alle norme EN55015, EN6100-3-2, EN6100-3-3, EN61347-1, EN61347-2-13, EN61547, EN62384.

Fattore di potenza  $\geq 0,95$ .

Prodotto conforme alle direttive: 

A RICHIESTA  
ON DEMAND

0-10V



EMERGENCY  
max duration  
1.30 hours

*it is a brilliant object that enhances work and communication environments both with the light effect and with the aesthetics. Ideal for working but also for relaxing and always having a pleasant atmosphere.*

*LED Unica is decidedly versatile in its use: offices and schools are the two most typical applications in which it proves to be the ideal solution in terms of economy and not only in terms of light but also in terms of maintenance.*

**Installation:** Suspension (accessories not included) or ceiling (with included assembly accessories).

**Body and frame:** structure in sheet steel.

**Coating:** powder polyester coating. White RAL 9010.

**Diffuser:** sheet in diffusing polycarbonate.

**Shield:** in 2mm thick opal polycarbonate.

**Color temperature:** 3000K or 4000K.

**Led:** maintenance of 80% minimum luminous flux: L80B20>50.000h.

**Driver:** compliant with standards EN55015, EN6100-3-2, EN6100-3-3, EN61347-1, EN61347-2-13, EN61547, EN62384.

Power factor  $\geq 0,95$ .

Product compliant with directives: 

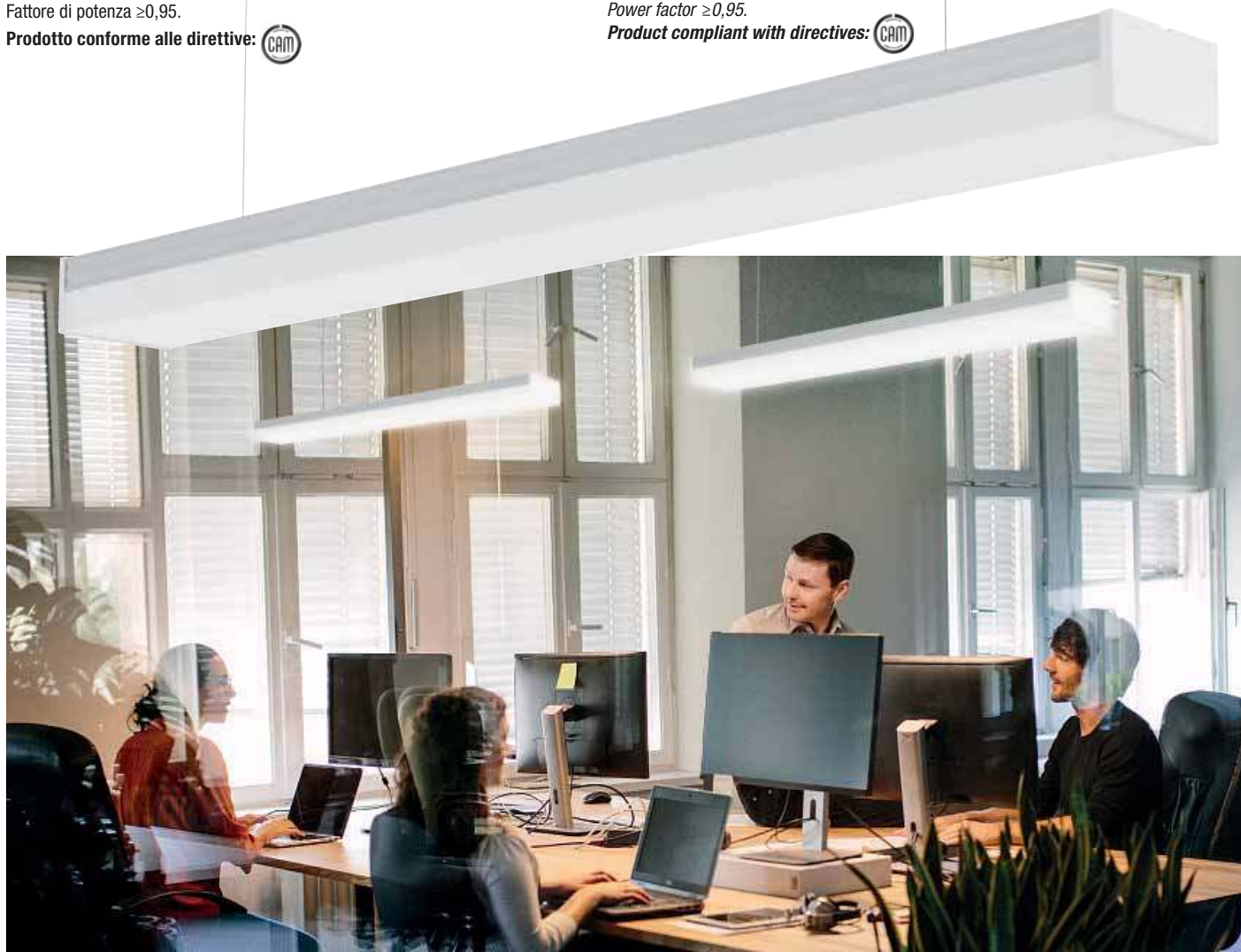

### Accessori non inclusi - Accessoires not included

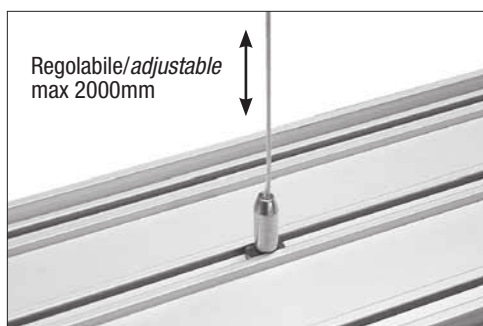

#### Cod.6025-S

Cavi per sospensione comprensivi di rosoni, saliscendi viti e tasselli.

*Suspension cables including rosettes, latch screws and plugs.*

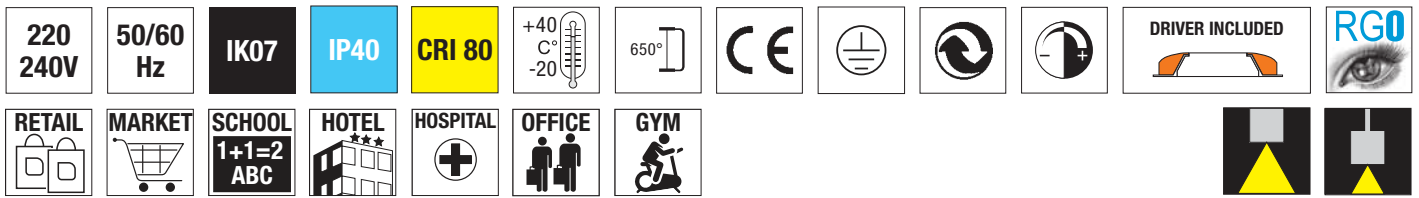

**LED Unica**

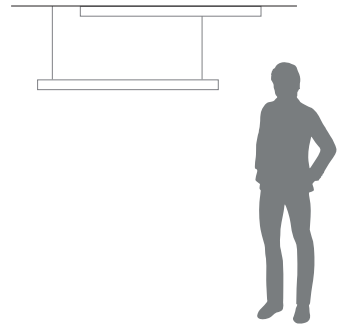
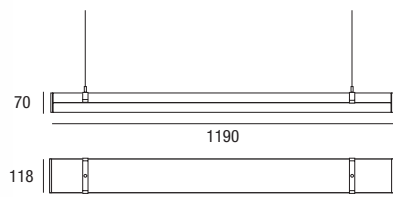

**Dati fotometrici  
Photometric data**

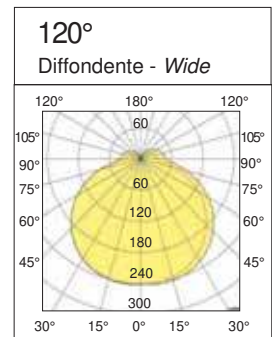

colour	W max	Vac	lm output	lm/W	K	pcs	Kg	CELL
B	24	220-240	2712	113	4000	001	4.50	6025-24
B	36	220-240	4068	113	4000	001	4.50	6025-36
B	48	220-240	5425	113	4000	001	4.50	6025-48
<b>DALI 2</b> B	24	220-240	2712	113	4000	001	4.50	6025-24DA
<b>DALI 2</b> B	36	220-240	4068	113	4000	001	4.50	6025-36DA
<b>DALI 2</b> B	48	220-240	5425	113	4000	001	4.50	6025-48DA
B	24	220-240	2712	113	3000	001	4.50	6025-243K
B	36	220-240	4068	113	3000	001	4.50	6025-363K
B	48	220-240	5425	113	3000	001	4.50	6025-483K
<b>DALI 2</b> B	24	220-240	2712	113	3000	001	4.50	6025-243KDA
<b>DALI 2</b> B	36	220-240	4068	113	3000	001	4.50	6025-363KDA
<b>DALI 2</b> B	48	220-240	5425	113	3000	001	4.50	6025-483KDA

Applicazione a soffitto o sospensione in linea continua, con collegamento in parallelo  
*Ceiling or suspension application continuous row, with parallel connection*

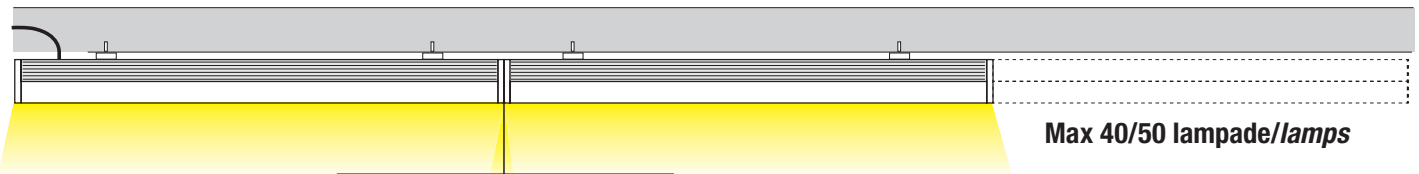

**Accessori inclusi - Included accessories**

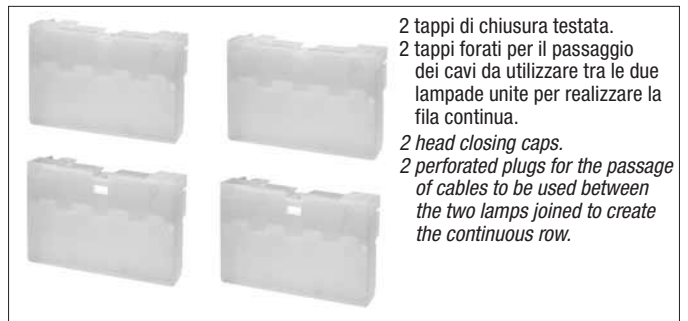

## Syros slim system S-C

Apparecchio singolo e fila continua  
Single devices and continuous line

A RICHIESTA  
ON DEMAND



### LED Syros slim S-C dark light, opale, asimmetrica.

Sistema luminoso modulare per file continue a sospensione o a plafone in versione dark light, opale o con lenti, uffici, reception, supermarket, palestre. Elementi di giunzione di semplice utilizzo per linee continue o accessorio per angoli a 90° a T e X non luminosi. Collegamento rapido con morsetto fast. Modulo cieco a richiesta predisposto per linea passante DALI, 0-10V. ed emergenza.

**Installazione:** a sospensione o a plafone.

**Corpo:** alluminio estruso anodizzato al naturale verniciato (goffrato) a polveri epossidiche bianco RAL 9010 e nero RAL 9005.

**Ottica dark Light:** parabola in alluminio 99,85, antiriflesso UGR<16 e antiridescente a bassissima luminanza.

**Ottica opale:** in policarbonato ad incastro a filo, UGR<19.

**Ottica asimmetrica e bi-asimmetrica:** in PMMA schermo trasparente.

**Conforme alla norma:** EN60598-1, RG0 nessun rischio fotobiologico ai fini della norma EN62471.

**Led:** Samsung SMD mantenimento del flusso luminoso minimo al 80%: L80B20>50.000h.

**Driver multipotenza:** Incluso > 50.000 h Fattore di potenza ≥0,95.

**A richiesta:** per quantità si esegue il settaggio dedicato della corrente del Driver e di conseguenza la potenza di W e Lm.

Prodotto conforme alle direttive:

### LED Syros slim S-C dark light, opal, asymmetrical.

Modular light system for continuous rows, suspension or ceiling, in dark light version, opal or with lenses, for offices, receptions, supermarkets, gyms. Easy to use joining elements for continuous lines or non-luminous T- and X-shaped 90° angle accessory. Quick connection with fast clamp. Dummy model on demand designed for DALI feedthrough line, 0-10V. and emergency.

**Installation:** suspension or ceiling.

**Body:** natural anodised extruded aluminium painted (Textured) with white RAL 9010 and black RAL 9005 epoxy powders.

**Dark light optics:** 99.85 aluminium parabola, antiglare UGR<16 and anti-iridescent, with very low luminance.

**Opal optics:** in flush joint polycarbonate, UGR<19.

**Asymmetric and bi-asymmetric optics :** in PMMA transparent screen.

**Compliant with standard:** : EN60598-1, RG0 no photobiological risk for the purposes mentioned in standard EN62471.

**Led:** Samsung SMD maintenance of 80% minimum luminous flux: L80B20>50.000h.

**Driver multipower:** Included > 50,000 h Power factor ≥0.95.

**On request:** for quantity, the dedicated setting of the Driver current and consequently the power of W and Lm is carried out.

Product compliant with directives:

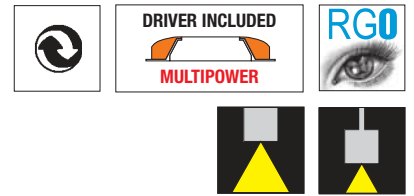
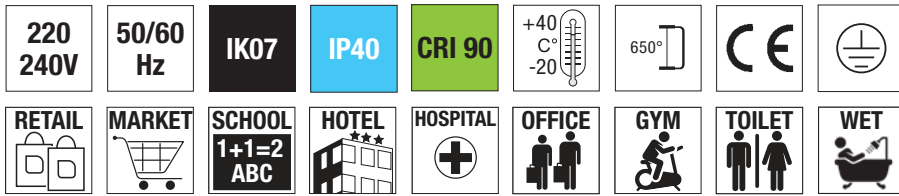

**Syros slim system S-C Dark light**

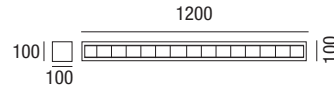
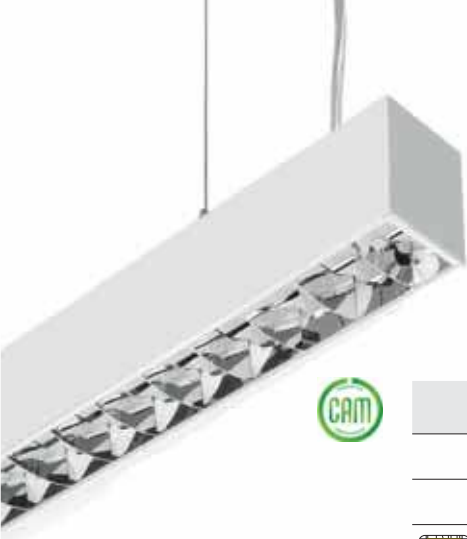

	colour	W max	Vac	lm output	lm/W	K	pcs/pallets	Kg	CELL
	B	40	220-240	5200	130	4000	60	4.50	25936/SL/SCDL
	N	40	220-240	5200	130	4000	60	4.50	25936SLSCDL/B
	B	40	220-240	5200	130	4000	60	4.50	25936SLSCDLDA
	N	40	220-240	5200	130	4000	60	4.50	25936SCDLDA/B
	B	60	220-240	7800	130	4000	60	4.50	25938/SL/SCDL
	N	60	220-240	7800	130	4000	60	4.50	25938SLSCDL/B
	B	60	220-240	7800	130	4000	60	4.50	25938SLSCDLDA
	N	60	220-240	7800	130	4000	60	4.50	25938SCDLDA/B

**85 W - 11.000 lm** A richiesta per quantità - *On request for quantity*

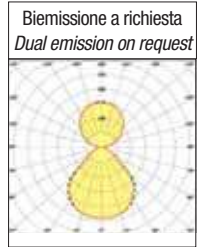
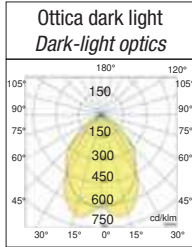

**EMER** Per lampade cablate in emergenza (aggiungere /EM dopo il codice) sovrapprezzo del 30%.  
For wired emergency lights (add /EM after the code) 30% extra charge.



Ceiling/suspended

## Installazione a sospensione Suspension installation



### kit sospensione (non incluso)

Con l'aggiunta di kit sospensione è possibile decidere l'altezza della lampada con facilità agendo direttamente sul pulsante si può aumentare o diminuire il cavo fino ad un max di 1500mm.

### suspension kit (not included)

With the addition of the suspension kit, you can easily decide the height of the lamp by acting directly on the button, you can increase or decrease the cable up to a maximum of 1500mm.

## Sistema biemissione a richiesta - applicabile ai modelli Syros Slim S, misure: 1200mm - 1800mm. Dual emission system on demand - applicable to Syros Slim S models, sizes: 1200mm - 1800mm.

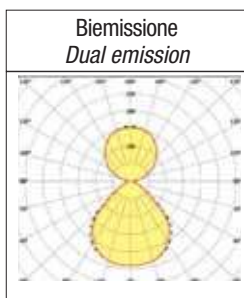

Biemissione con unica accensione, sovrapprezzo del 30% (aggiungere /DM dopo il codice).

Biemissione con doppia accensione, sovrapprezzo del 40% (aggiungere /2DM dopo il codice).

*Bi-emission with single ignition, 30% surcharge (add /DM after the code).*

*Bi-emission with double ignition, 40% surcharge (add /2DM after the code).*

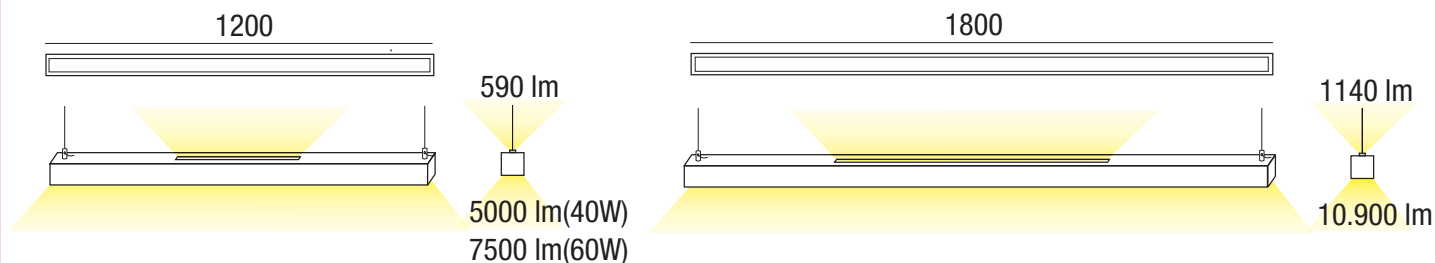

# Syros slim system S-C

## Syros slim system S-C Opal

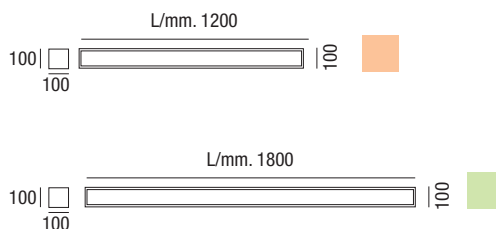

colour	W max	Vac	lm output	lm/W	K	L [mm]	pcs/pallets	Kg	CELL
B	40	220-240	5000	125	4000	1200	60	4.50	25940/SL/SCOP
B	40	220-240	5000	125	3000K	1200	60	4.50	25940SLSCOP3K
N	40	220-240	5000	125	4000	1200	60	4.50	25940SLSCOPBL
N	40	220-240	5000	125	3000K	1200	60	4.50	25940SLSCOPBL3K
DALI 2 PUSH B	40	220-240	5000	125	4000	1200	60	4.50	25940SLSCOPDA
DALI 2 PUSH N	40	220-240	5000	125	4000	1200	60	4.50	25940SCOPDABL
B	60	220-240	7500	125	4000	1200	60	4.50	25942/SL/SCOP
N	60	220-240	7500	125	4000	1200	60	4.50	25942SLSCOP/B
DALI 2 PUSH B	60	220-240	7500	125	4000	1200	60	4.50	25942SLSCOPDA
DALI 2 PUSH N	60	220-240	7500	125	4000	1200	60	4.50	25942SCOPDA/B

colour	W max	Vac	lm output	lm/W	K	L [mm]	pcs/pallets	Kg	CELL
B	85	220-240	11.000	129	4000	1800	60	5.00	25947/SL/SCOP
B	85	220-240	11.000	129	3000K	1800	60	5.00	25947SLSCOP3K
N	85	220-240	11.000	129	4000	1800	60	5.00	25947SLSCOPBL
N	85	220-240	11.000	129	3000K	1800	60	5.00	25947SLSCOPBL3K
DALI 2 PUSH B	85	220-240	11.000	129	4000	1800	60	5.00	25949SLSCOPDA
DALI 2 PUSH N	85	220-240	11.000	129	4000	1800	60	5.00	25949SCOPDA/B

**EMER** Per lampade cablate in emergenza (aggiungere /EM dopo il codice) sovrapprezzo del 30%.  
For wired emergency lights (add /EM after the code) 30% extra charge.

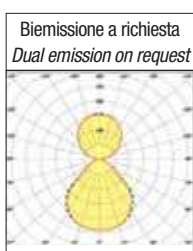
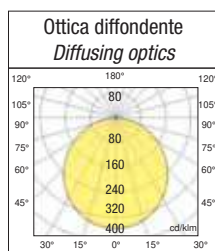

## Installazione a plafone con accessori inclusi Ceiling installation with included accessories



# Syros slim system S-C



Ceiling/suspended

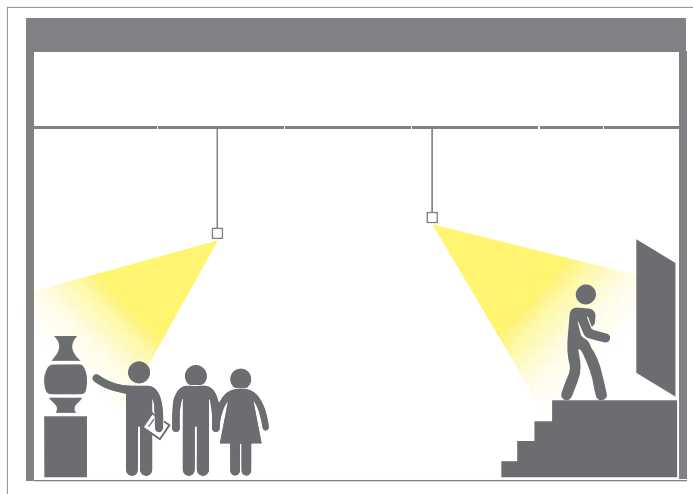

## Ottica asimmetrica

Ideale per l'illuminazione di pareti in modo uniforme.

## Asymmetric optics

Ideal for evenly lighting walls.

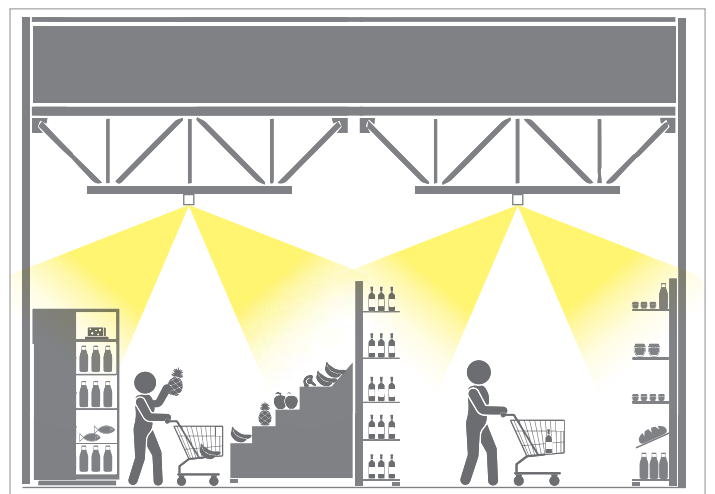

## Ottica bi-asimmetrica

Adatta per gli spazi commerciali al fine di dare maggior risalto alla merce esposta rispetto alle corsie.

## Bi-asymmetric optics

Suitable for sales spaces to allow the displayed goods to stand out respect to the lanes.

# Syros slim system S-C

## Syros slim system S-C asimmetrica

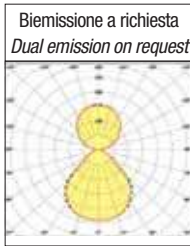
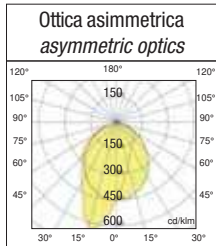
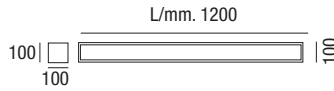

	colour	W max	Vac	lm output	lm/W	K	pcs/pallets	Kg	CELL
	B	40	220-240	5200	130	4000	60	4.50	25943/SL/SCWW
	<b>DALI 2</b> PUSH B	40	220-240	5200	130	4000	60	4.50	25943SLSCWWDA
	B	60	220-240	7800	130	4000	60	4.50	25944/SL/SCWW
	<b>DALI 2</b> PUSH B	60	220-240	7800	130	4000	60	4.50	25944SLSCWWDA

**EMER** Per lampade cablate in emergenza (aggiungere /EM dopo il codice) sovrapprezzo del 30%.  
For wired emergency lights (add /EM after the code) 30% extra charge.

## 3S Syros slim system bi-asimmetrica

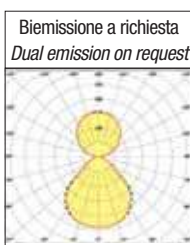
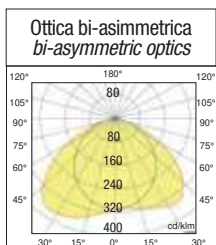
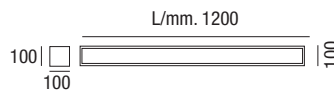

	colour	W max	Vac	lm output	lm/W	K	pcs/pallets	Kg	CELL
	B	40	220-240	5200	130	4000	60	4.50	25945/SL/SC2A
	<b>DALI 2</b> PUSH B	40	220-240	5200	130	4000	60	4.50	25945SLSC2ADA
	B	60	220-240	7800	130	4000	60	4.50	25946/SL/SC2A
	<b>DALI 2</b> PUSH B	60	220-240	7800	130	4000	60	4.50	25946SLSC2ADA

**EMER** Per lampade cablate in emergenza (aggiungere /EM dopo il codice) sovrapprezzo del 30%.  
For wired emergency lights (add /EM after the code) 30% extra charge.

# Syros slim system accessori - accessories

Serie di accessori che consentono il fissaggio in linea della famiglia Syros Slim.  
 Series of accessories that allow the Syros Slim family to be fixed in line.

## Accessori a richiesta - Accessoires on demand

**Modulo cieco** - predisposto con cablaggio per linee passanti e DALI o 0-10V. + EMERGENZA.

**Non-luminous pipe** - set up with wiring for through- and DALI or 0-10V lines. + EMERGENCY.

Colour		pcs	Kg	Code	
B	7 FILI/WIRE	1.200	001	3,80	25940/SL/SC

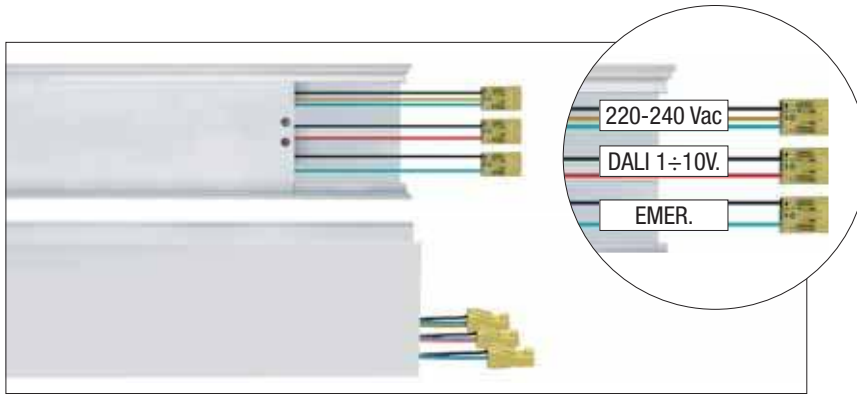
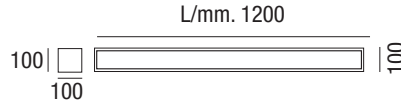

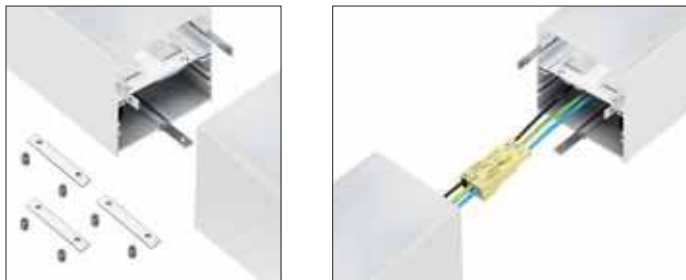

## Staffe di giunzione (KIT 3 pezzi) - Junction brackets (Kit 3 pieces)

Colour	pcs	Kg	Code
B	1	0,01	25803/SL



## Kit di alimentazione - Power supply kit

Colour	Cavo	pcs	Kg	Code	
B	3x1,5	1	0,01	102/3/C	
B	5x1,5		1	0,01	102/5/C
N	3x1,5	1	0,01	102B/3/C	
N	5x1,5		1	0,01	102B/5/C

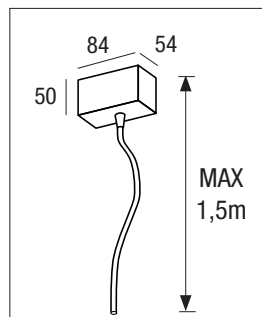

## Cavo per sospensione - Suspension cable

pcs	Kg	PCS	Code
001	0,250	1 cavi/cables	103/S

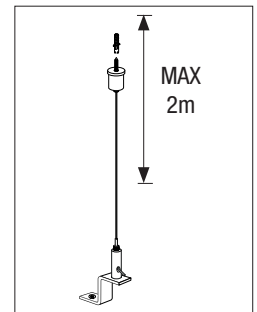
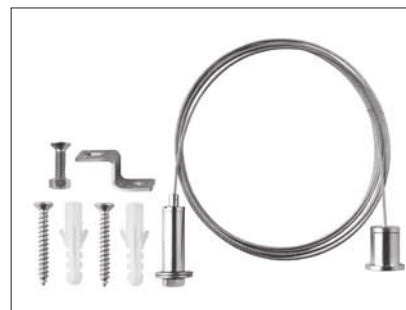

# Syros slim system accessori - accessories

## Giunto angolare a L - T - X con 4 tappi chiusura L - T - X-shaped corner joint with 4 closure caps

Colour	pcs	Kg	Code
<b>B</b>	1	0,20	25802/SL
<b>N</b>	1	0,20	25802/SLBL

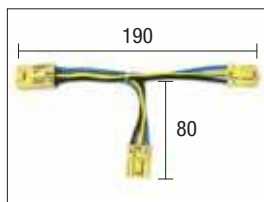
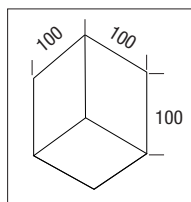
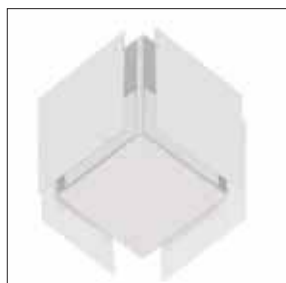

Soluzioni NON incluse per aumentare il risparmio energetico  
Solutions NOT included to increase energy saving

## Giunto angolare a L - T - X con rilevatore di presenza ad infrarossi, telecomando e 4 tappi chiusura L - T - X angular joint with infrared presence detector, remote control and 4 closure caps

Colour	pcs	Kg	Code
<b>0-10V</b> <b>B</b>	1	0,87	HIR22/SYROS/DI
<b>DALI</b> <b>B</b>	1	0,87	HIR23/SYROS/DA

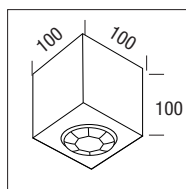

### Ampiezza rilevamento Detection width

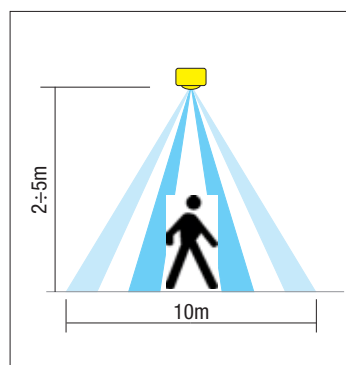

HIR22/SYROS/DI



Angolo di rivelamento Detection angle	360°
Altezza di montaggio Assembly height	2÷5 metri
Ampiezza rilevamento Detection Width	Ø 10m
Assorbimento stand by Stand-by absorption	<0,5W

HIR23/SYROS/DA



Angolo di rivelamento Detection angle	360°
Altezza di montaggio Assembly height	2÷5 metri
Ampiezza rilevamento Detection Width	Ø 10m
Assorbimento stand by Stand-by absorption	<0,5W Max 64 Driver conforme allo standard DALI <0,5W Max 64 drivers compliant with DALI standard

Cod. HRC-11

#### Accessorio NON incluso

L'utilizzo del telecomando HRC-11 permette di modificare le impostazioni senza dover accedere direttamente al trimmer integrato

#### NOT included accessory

Using the HRC-11 remote control allows you to change settings without needing to directly access the built-in trimmer.



# Syros slim sospensione, esempio applicativo

## Syros slim suspension, application example

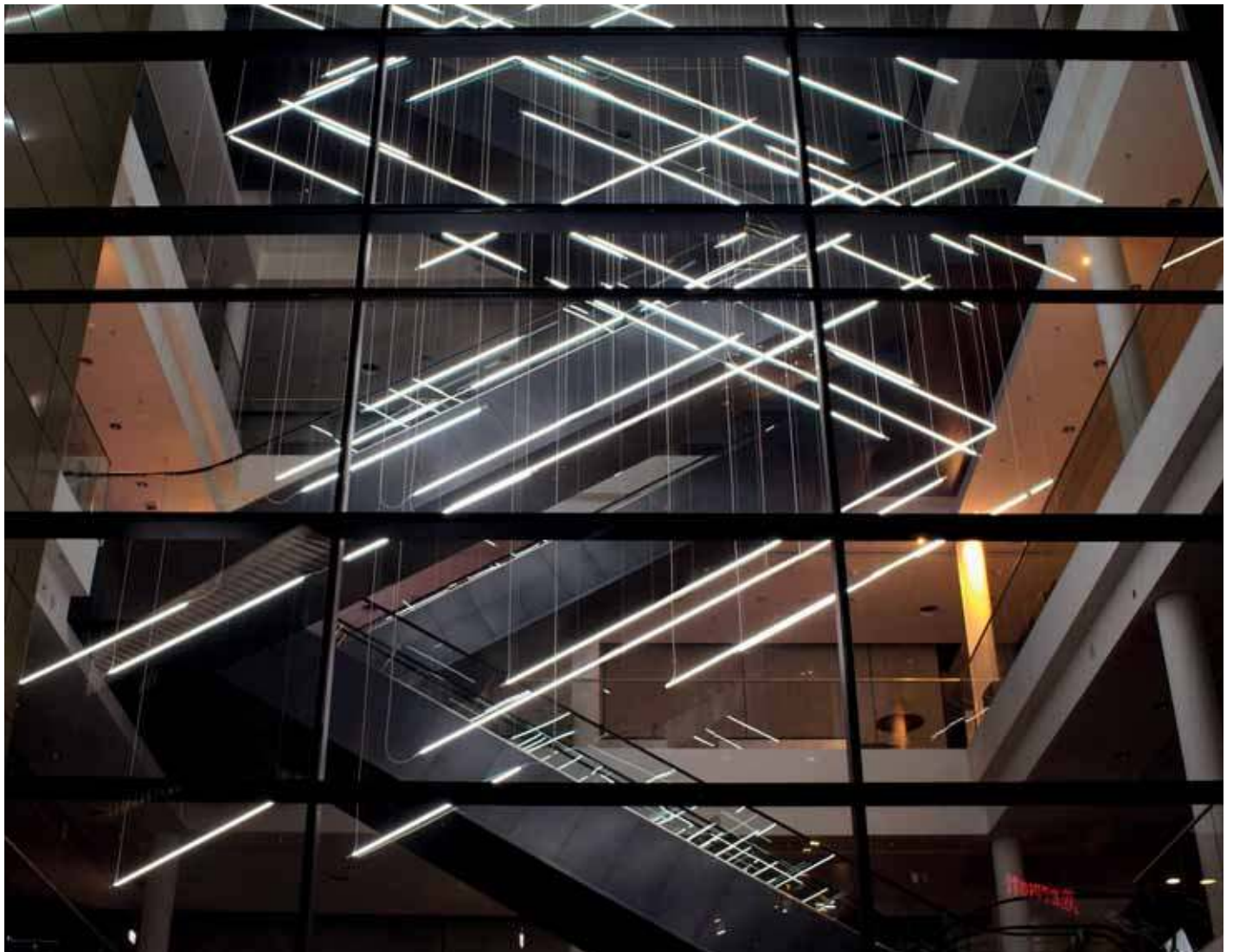
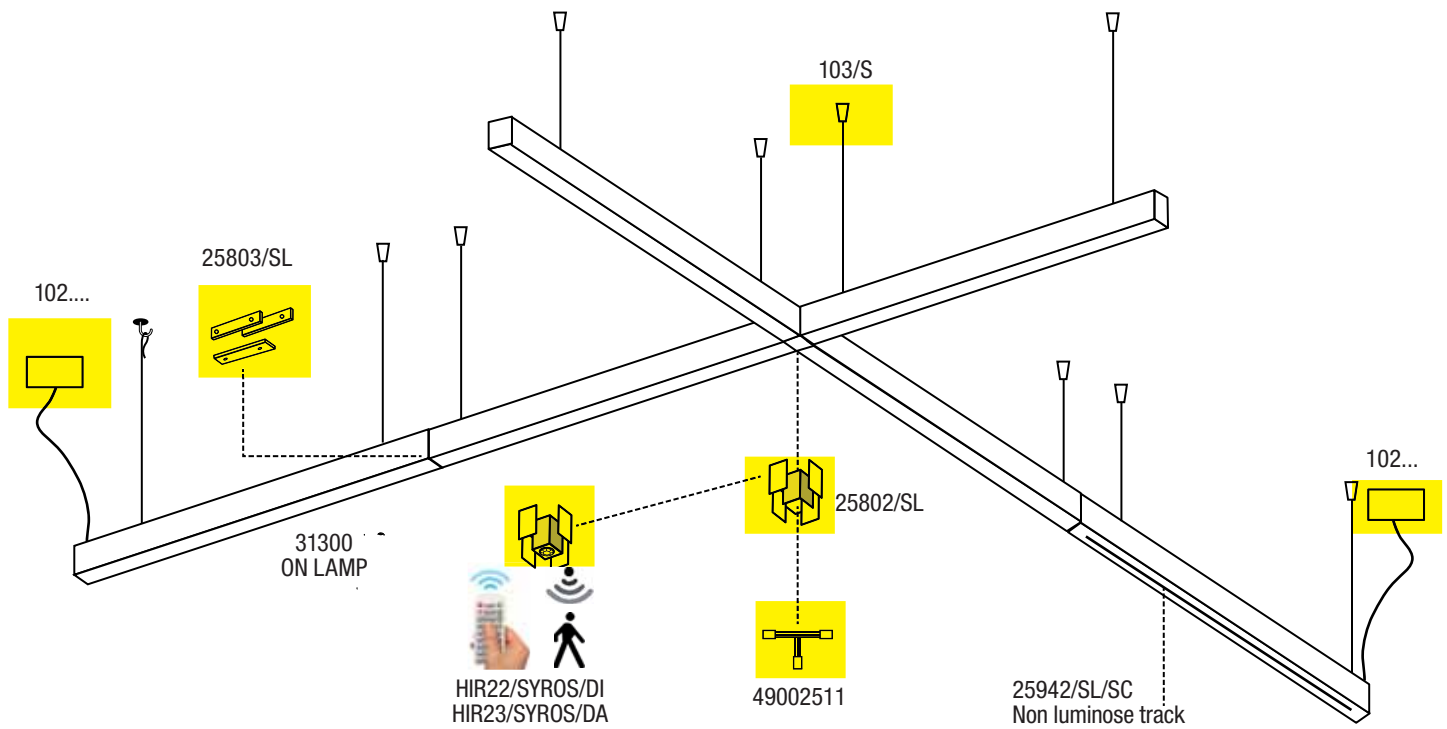

Ceiling/suspended

## Sky system S-C-W 40x40

Apparecchio singolo e fila continua  
Single devices and continuous line

A RICHIESTA  
ON DEMAND

0-10V

DALI 2



WIRELESS

EMER

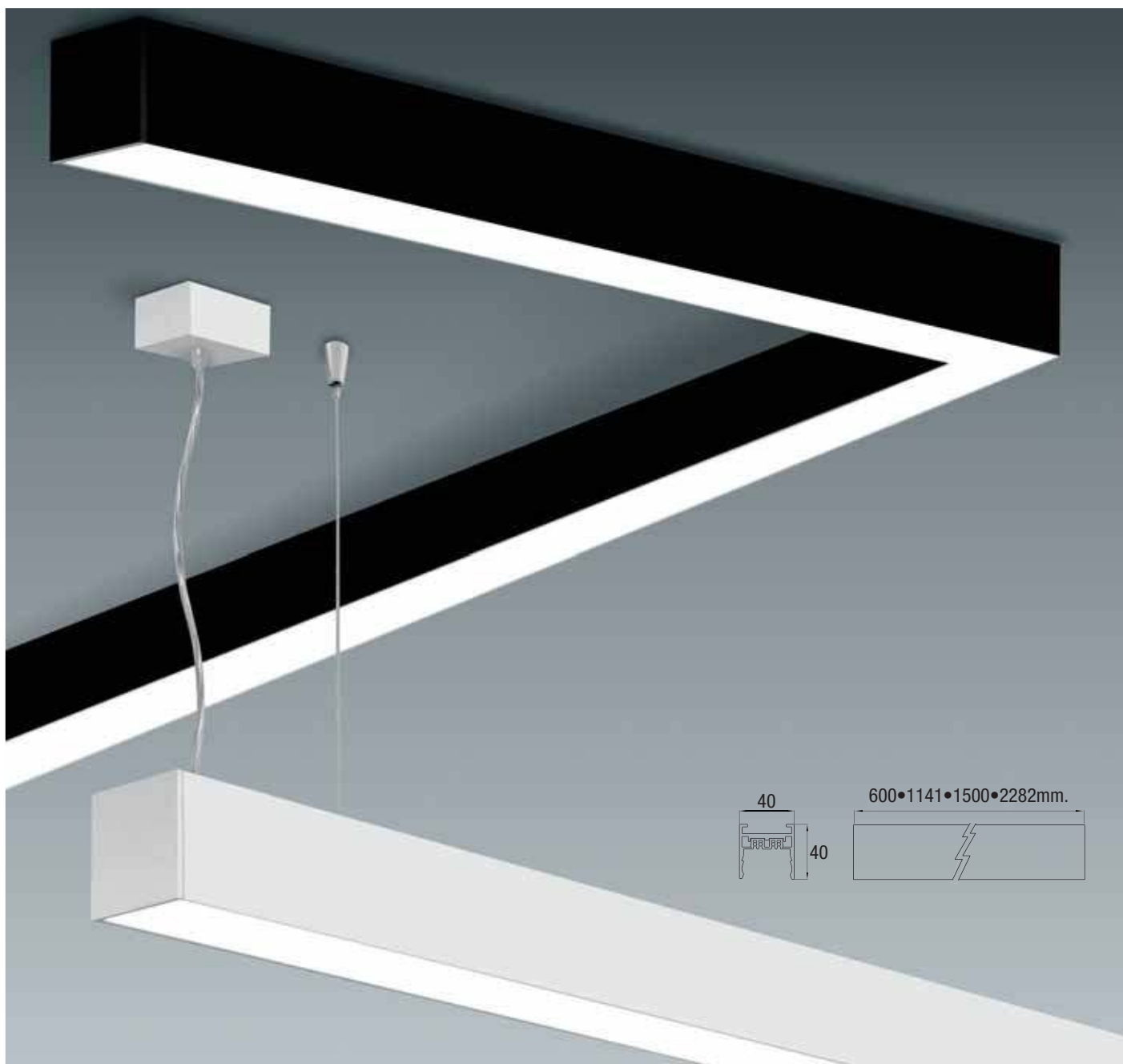

### LED Sky slim S-C dark light, opale, asimmetrica.

Sistema luminoso modulare di spessore ridotto per file continue a sospensione o plafone in versione opale o con lenti, uffici, reception, supermarket, palestre. Elementi di giunzione di semplice utilizzo per linee continue o accessorio per angoli a 90°.

Collegamento rapido con morsetto fast. Modulo cieco a richiesta predisposto per linea passante DALI, 0-10V. ed emergenza.

**A richiesta modello Biemissione.**

**Installazione:** a sospensione S e parete W o a plafone C con accessorio (non incluso), per montaggio a plafone in fila continua utilizzare lo specifico accessorio (non incluso).

**Corpo:** alluminio estruso anodizzato al naturale verniciato (goffrato) a polveri epossidiche bianco RAL 9010 e nero RAL 9005.

**Diffusore:** in policarbonato trasparente ad incastro a filo + film microstrutturato.

**Diffusore asimmetrico e bi-asimmetrica:** lenti in PMMA e diffusore trasparente.

**Conforme alla norma:** EN60598-1, RG0 nessun rischio fotobiologico ai fini della norma EN62471.

**Led:** Samsung SMD mantenimento del flusso luminoso minimo L80B20>50.000h.

**Driver multipotenza:** Incluso > 50.000 h Fattore di potenza ≥0,95.

**A richiesta:** per quantità si esegue il settaggio dedicato della corrente del Driver e di conseguenza la potenza di W e Lm.

**Prodotto conforme alle direttive:**

### LED Sky slim S-C dark light, opal, asymmetrical.

Modular light system with reduced thickness for continuous rows, suspension or ceiling, in opal version or with lenses, for offices, receptions, supermarkets, gyms. Easy to use joining elements for continuous lines or 90° angle accessory.

Quick connection with fast clamp. Dummy model on demand designed for DALI feedthrough line, 0-10V. and emergency.

**On request Bi-emission model.**

**Installation:** suspension S or wall W or on ceiling C with accessory (included), for ceiling mounting in a continuous row use the specific accessory (not included).

**Body:** natural anodised extruded aluminium painted (Textured) with white RAL 9010 and black RAL 9005 epoxy powders.

**Diffuser:** in flush joint transparent polycarbonate + microstructured film.

**Asymmetric and bi-asymmetric diffuser:** lens in clear PMMA and transparent diffuser.

**Compliant with standard:** EN60598-1, RG0 no photobiological risk for the purposes mentioned in standard EN62471.

**Led:** Samsung SMD maintenance of 80% minimum luminous flux: 50,000h (L80B10).

**Multipower driver:** Included > 50,000 h Power factor ≥0.95.

**On request:** for quantity, the dedicated setting of the Driver current and consequently the power of W and Lm is carried out.

**Product compliant with directives:**

# Sky system per il Food

Per valorizzare i generi alimentari e prodotti freschi come frutta, verdura, pane e carne, è possibile (a richiesta) avere il sistema Sky con LED dedicati.

To enhance food and fresh products such as fruit, vegetables, bread and meat, it is possible (on request) to have the Sky system with dedicated LEDs.



## Ottica bread

la luce calda rivela la naturale colorazione di farinacei e prodotti di pasticceria  
*the warm light accentuates the natural coloring of starchy and pastry products*



## Ottica fruit -vegetables

aumenta la sensazione del cliente di acquistare di frutta e verdura fresche appena colte.  
*increases the customer's feeling of buying freshly picked fresh fruit and vegetables.*



## Ottica meat

accentua il colore della carne e dei salumi e ne risalta la freschezza.  
*accentuates the color of meat and cured meats and enhances their freshness.*



## Ottica fish

con luce fredda "glaciale" risalta la naturale freschezza del pesce e dei crostacei appena pescati  
*with cold "glacial" light, the natural freshness of freshly caught fish and crustaceans stands out*

## Sky system Emergenza Autotest a richiesta

Le norme europee EN 1838, EN 60598-2-22, relative ai sistemi di illuminazione di emergenza, impongono che periodicamente, siano effettuati dei test per verificare sia il funzionamento sia l'efficienza (durata in emergenza) degli apparecchi di illuminazione che svolgono anche la funzione di illuminazione di emergenza. Questo costringe i manutentori dell'impianto ad interrompere la linea di alimentazione ed effettuare test con cadenza settimanale (test funzionale), e con cadenza trimestrale o annuale (test di autonomia).

Con i nostri kit di emergenza con autotest (conformi alla normativa europea EN 62034) queste prove vengono svolte automaticamente con cadenza programmabile in fase di installazione. Inoltre il nostro inverter analizza i tempi di normale accensione e spegnimento dell'apparecchio ed effettua (qualora possibile) i test nelle ore di assenza delle persone.

Eventuali anomalie sono segnalate tramite un indicatore (led) rosso verde.

A partire dal colore della segnalazione è possibile stabilire in maniera univoca gli eventuali problemi di funzionamento come evidenziato nella tabella seguente.

## Safety Lighting Autotest on request

The European standards EN 1838, EN 60598-2-22, relating to emergency lighting systems, require that tests be periodically carried out to verify both the functioning and the efficiency (duration in emergency) of the lighting fixtures which also the emergency lighting function. This forces the system maintainers to interrupt the power supply line and carry out tests on a weekly basis (functional test), and on a quarterly or annual basis (autonomy test).

With our emergency kits with self-test (complying with European standard EN 62034) these tests are carried out automatically with a programmable cadence during installation.

Furthermore, our inverter analyzes the normal switching on and off times of the appliance and carries out (where possible) the tests in the hours when people are absent.

Any anomalies are signaled by a red-green indicator (led). Starting from the color of the signal, it is possible to unequivocally establish any functioning problems as shown in the following table.

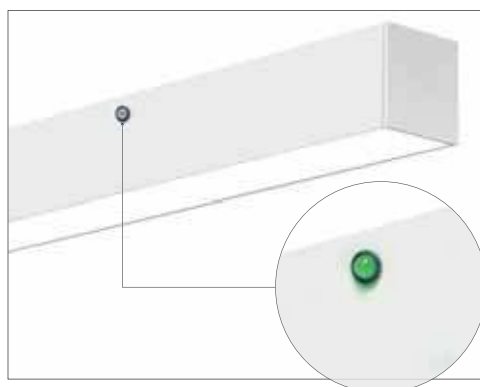

Colore LED - LED indication		Stato - Status
	Verde fisso - Permanent Green	Batteria carica o in carica - Battery charge or charging
	Verde lampeggiante - Flashing Green	Funzione TEST avviata - TEST in progress
	Verde lampeggiante lento (1s ON - 1s OFF) Slow flashing green (1s ON - 1s OFF)	TEST di autonomia avviato Autonomy TEST in progress
	Rosso fisso - Permanent Red	Lampada guasta - Lamp failure
	Rosso lampeggio veloce (0,1s ON - 0,1s OFF) Fast flashing Red (0,1s ON - 0,1s OFF)	Guasto circuito di ricarica - Charging failure
	Lampeggio Rosso lento (1s ON - 1s OFF) Slow flashing Red (1s ON - 1s OFF)	Batteria guasta - Battery failure
	Verde e Rosso OFF - Green and Red OFF	Emergenza ON - Emergency ON



Ottica asimmetrica - *Asymmetric optics*

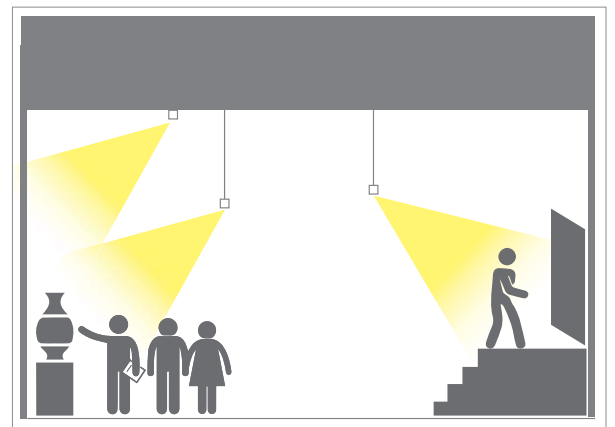

Ottica bi-asimmetrica - *Bi-asymmetric optics*

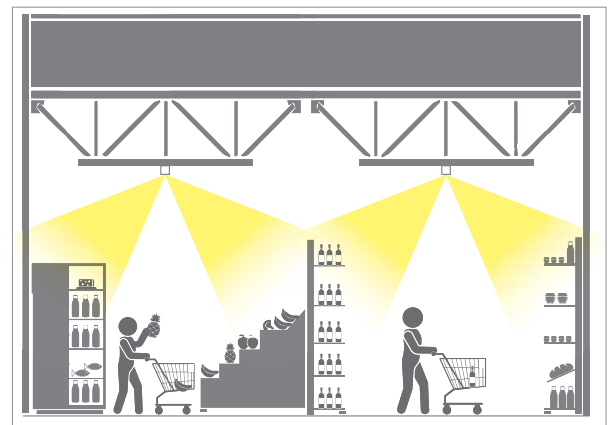

220 240V	50/60 Hz	IK07	IP40	CRI 90	+40 C° -20	850°	CE				DRIVER INCLUDED MULTIPOWER	RG0
RETAIL	MARKET	SCHOOL 1+1=2 ABC	HOTEL	HOSPITAL	OFFICE	GYM	TOILET	EMER	Per lampade cablate in emergenza (aggiungere /EM dopo il codice) sovrapprezzo del 30%. Emergenza non possibile per versioni in linea continua. For wired emergency lights (add /EM after the code) 30% extra charge. Emergency not possible for versions in continuous line.			

### Sky system S-C 40x40

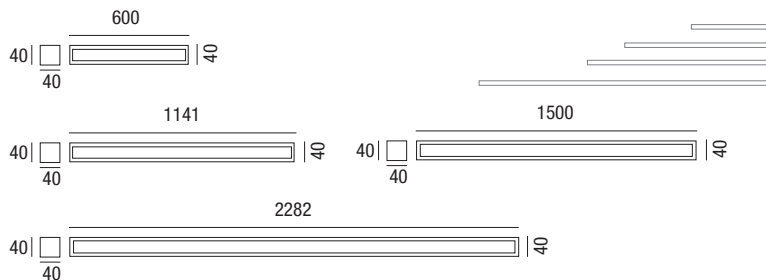

	colour	W max	Vac	lm output	lm/W	K	L [mm]	Kg	CELL
	B	16	220-240	2080	130	3000	600	2.00	603K
	B	16	220-240	2080	130	4000	600	2.00	604K
	DALI 2 PUSH B	16	220-240	2080	130	3000	600	2.00	603KDA
	DALI 2 PUSH B	16	220-240	2080	130	4000	600	2.00	604KDA
	N	16	220-240	2080	130	3000	600	2.00	60B3K
	N	16	220-240	2080	130	4000	600	2.00	60B4K
	DALI 2 PUSH N	16	220-240	2080	130	3000	600	2.00	60B3KDA
	DALI 2 PUSH N	16	220-240	2080	130	4000	600	2.00	60B4KDA
	B	30	220-240	3900	130	3000	1141	2.00	1003K
	B	30	220-240	3900	130	4000	1141	2.00	1004K
	DALI 2 PUSH B	30	220-240	3900	130	3000	1141	2.00	1003KDA
	DALI 2 PUSH B	30	220-240	3900	130	4000	1141	2.00	1004KDA
	N	30	220-240	3900	130	3000	1141	2.00	100B3K
	N	30	220-240	3900	130	4000	1141	2.00	100B4K
	DALI 2 PUSH N	30	220-240	3900	130	3000	1141	2.00	100B3KDA
	DALI 2 PUSH N	30	220-240	3900	130	4000	1141	2.00	100B4KDA
	B	40	220-240	5200	130	3000	1500	4.00	1503K
	B	40	220-240	5200	130	4000	1500	4.00	1504K
	DALI 2 PUSH B	40	220-240	5200	130	3000	1500	4.00	1503KDA
	DALI 2 PUSH B	40	220-240	5200	130	4000	1500	4.00	1504KDA
	N	40	220-240	5200	130	3000	1500	4.00	150B3K
	N	40	220-240	5200	130	4000	1500	4.00	150B4K
	DALI 2 PUSH N	40	220-240	5200	130	3000	1500	4.00	150B3KDA
	DALI 2 PUSH N	40	220-240	5200	130	4000	1500	4.00	150B4KDA
	B	50	220-240	6500	130	3000	2282	4.00	2203K
	B	50	220-240	6500	130	4000	2282	4.00	2204K
	DALI 2 PUSH B	50	220-240	6500	130	3000	2282	4.00	2203KDA
	DALI 2 PUSH B	50	220-240	6500	130	4000	2282	4.00	2204KDA
	N	50	220-240	6500	130	3000	2282	4.00	220B3K
	N	50	220-240	6500	130	4000	2282	4.00	220B4K
	DALI 2 PUSH N	50	220-240	6500	130	3000	2282	4.00	220B3KDA
	DALI 2 PUSH N	50	220-240	6500	130	4000	2282	4.00	220B4KDA
	B	60	220-240	7800	130	3000	2282	4.00	2003K
	B	60	220-240	7800	130	4000	2282	4.00	2004K
	DALI 2 PUSH B	60	220-240	7800	130	3000	2282	4.00	2003KDA
	DALI 2 PUSH B	60	220-240	7800	130	4000	2282	4.00	2004KDA
	N	60	220-240	7800	130	3000	2282	4.00	200B3K
	N	60	220-240	7800	130	4000	2282	4.00	200B4K
	DALI 2 PUSH N	60	220-240	7800	130	3000	2282	4.00	200B3KDA
	DALI 2 PUSH N	60	220-240	7800	130	4000	2282	4.00	200B4KDA

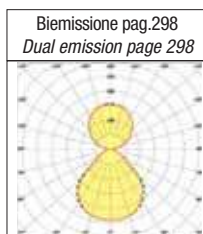
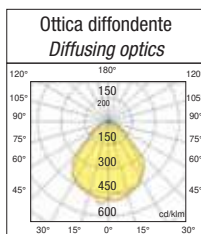

## Sky system S-C bi-asimmetrica

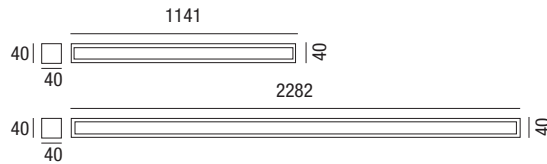

Ottica bi-asimmetrica  
bi-asymmetric optics

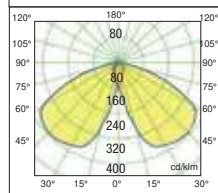

Biemissione pag.298  
Dual emission page 298

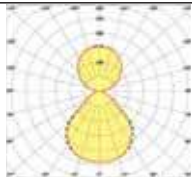

	colour	W max	Vac	lm output	lm/W	K	L [mm]	Kg	CELL
	B	30	220-240	3900	130	3000	1141	2.00	100BAS3K
	B	30	220-240	3900	130	4000	1141	2.00	100BAS4K
	DALI 2 PUSH B	30	220-240	3900	130	3000	1141	2.00	100BAS3KDA
	DALI 2 PUSH B	30	220-240	3900	130	4000	1141	2.00	100BAS4KDA
	N	30	220-240	3900	130	3000	1141	2.00	100BASB3K
	N	30	220-240	3900	130	4000	1141	2.00	100BASB4K
	DALI 2 PUSH N	30	220-240	3900	130	3000	1141	2.00	100BASB3KDA
	DALI 2 PUSH N	30	220-240	3900	130	4000	1141	2.00	100BASB4KDA
	B	50	220-240	6500	130	3000	2282	4.00	200BAS3K
	B	50	220-240	6500	130	4000	2282	4.00	200BAS4K
	DALI 2 PUSH B	50	220-240	6500	130	3000	2282	4.00	200BAS3KDA
	DALI 2 PUSH B	50	220-240	6500	130	4000	2282	4.00	200BAS4KDA
	N	50	220-240	6500	130	3000	2282	4.00	200BASB3K
	N	50	220-240	6500	130	4000	2282	4.00	200BASB4K
	DALI 2 PUSH N	50	220-240	6500	130	3000	2282	4.00	200BASB3KDA
	DALI 2 PUSH N	50	220-240	6500	130	4000	2282	4.00	200BASB4KDA

## Sky system Ottica ellittica a richiesta - Sky system Elliptical optic on demand

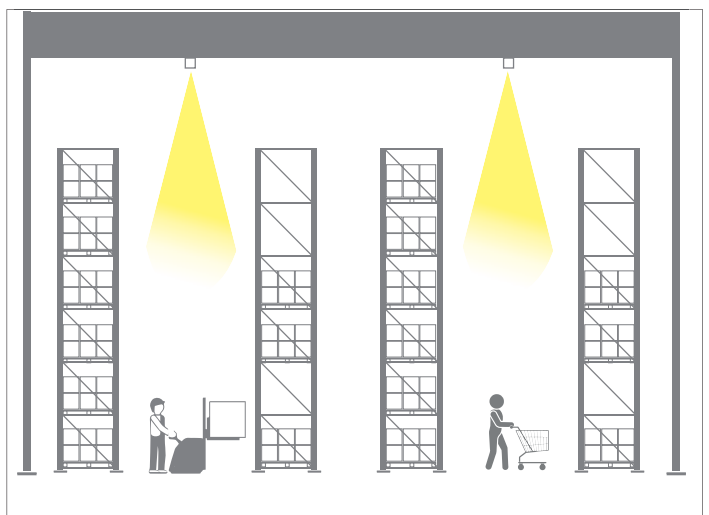

Ottica Ellittica  
Elliptical optics

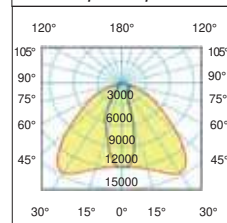

A richiesta ottica ellittica 30°x90°

Ideale per illuminare ambienti con alte scaffalature o lunghi corridoi per la vendita al dettaglio, in modo da avere una luce diffusa e uniforme.

*On request elliptical optic 30°x90°*

*Ideal for lighting environments with high shelves or long corridors for retail, so as to have a uniformly diffused light.*

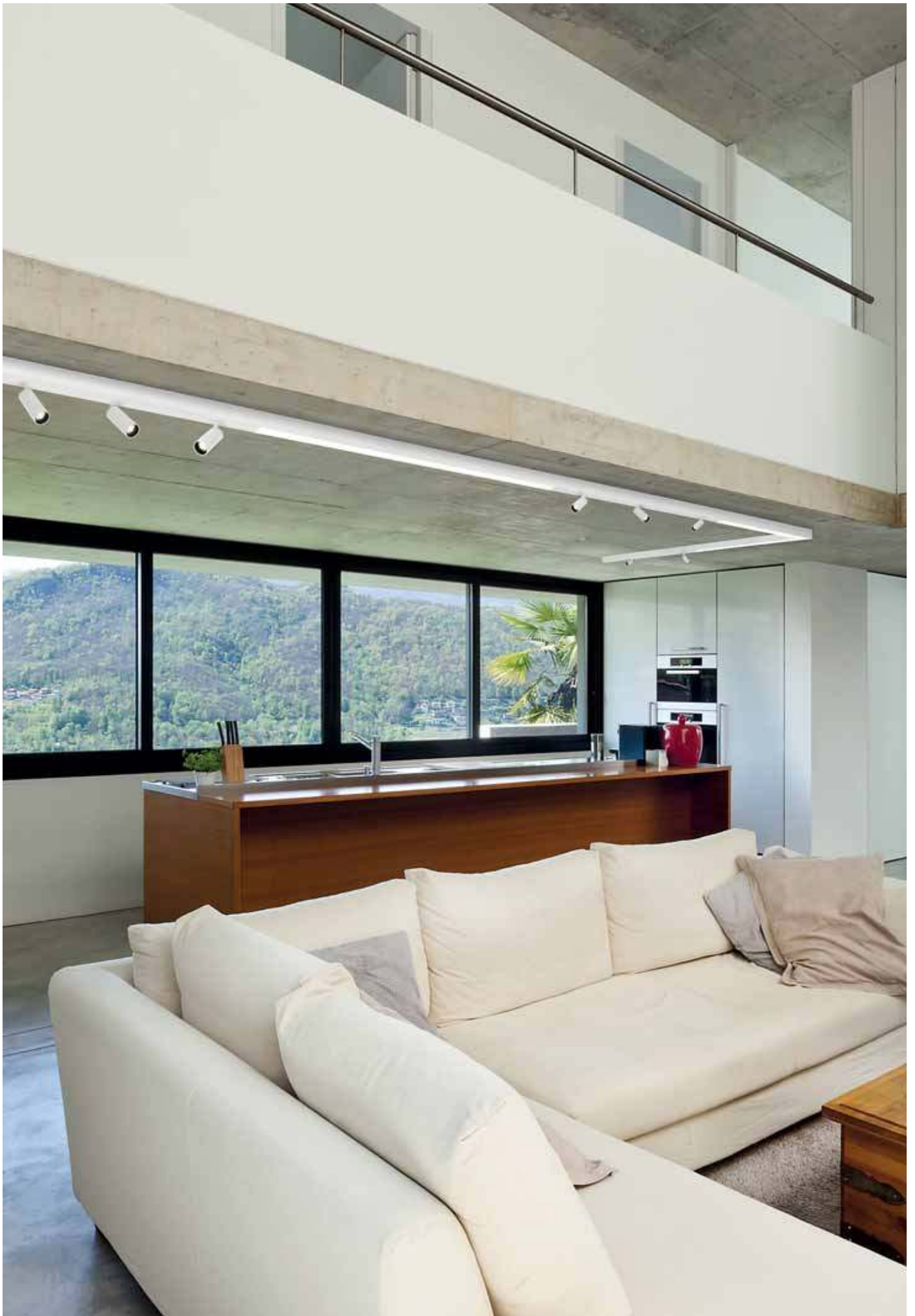

**Sky system 2 SPOT L. 1141 mm.**

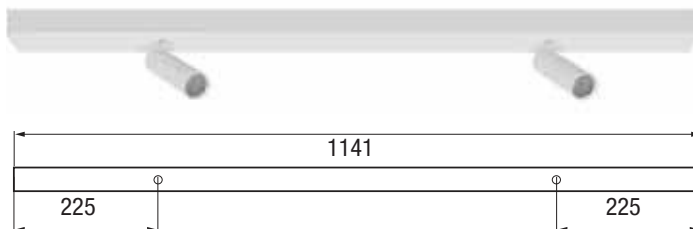

Colour	W	lm output	K	Angolo	Code
<b>B</b>	2x10	2x1700	4000	15 (36)	2SPOT/4K/15
<b>N</b>	2x10	2x1700	4000	15 (36)	2SPOT/B/4K/15

**Sky system 3 SPOT L. 1141 mm.**

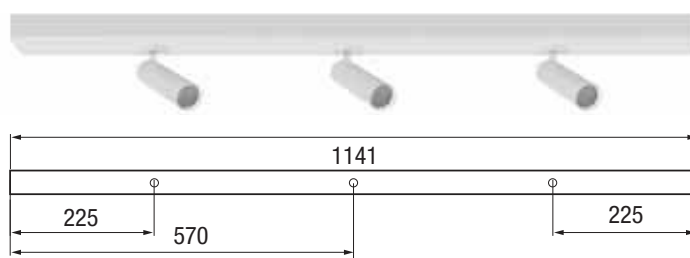

Colour	W	lm output	K	Angolo	Code
<b>B</b>	3x10	3x1700	4000	15 (36)	3SPOT/4K/15
<b>N</b>	3x10	3x1700	4000	15 (36)	3SPOT/B/4K/15

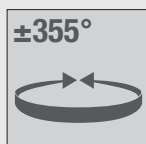
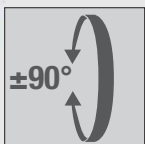

Spot 15°

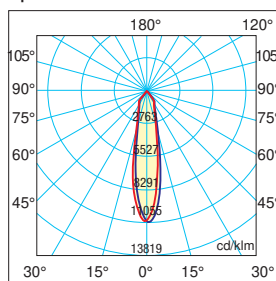

Spot 36°a richiesta  
on demand

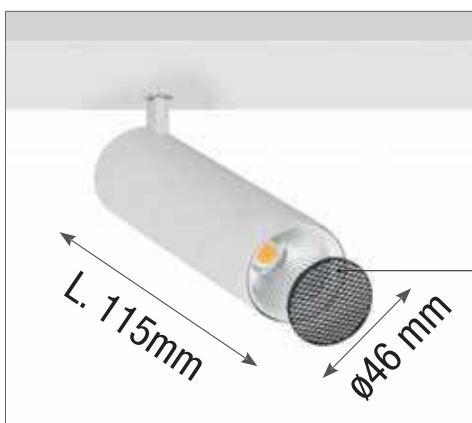
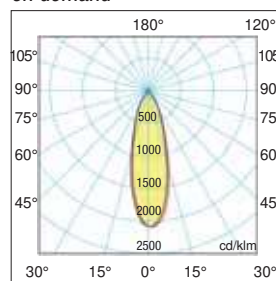

Frangiluce nido d'ape  
INCLUSO.  
INCLUDED  
Honeycomb louvre



**Sistema biemissione a richiesta** - applicabile ai modelli Led Sky system misure: 1141mm - 1500mm - 2282 mm.  
**Dual emission system on demand** - applicable to Led Sky system models, sizes: 1141mm - 1500mm - 2282 mm.

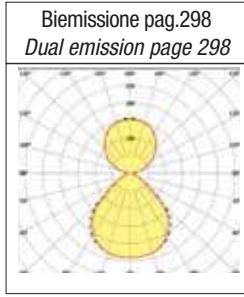

Biemissione con unica accensione, sovrapprezzo del 30% (aggiungere /DM dopo il codice).  
 Biemissione con doppia accensione, sovrapprezzo del 40% (aggiungere /2DM dopo il codice).  
**Non disponibile per Congiunzioni luminose a "T" o a "C".**  
*Bi-emission with single ignition, 30% surcharge (add /DM after the code).*  
*Bi-emission with double ignition, 40% surcharge (add /2DM after the code).*  
**Not available for "T" or "C" Light Conjunctions.**



**Accessori inclusi**  
**Included accessoires**

Frangiluce, evita che il flusso luminoso trafile tra i moduli Sky system in fila continua.  
*Louvre mask, prevents the luminous flux from leaking between the Sky system modules in a continuous row.*

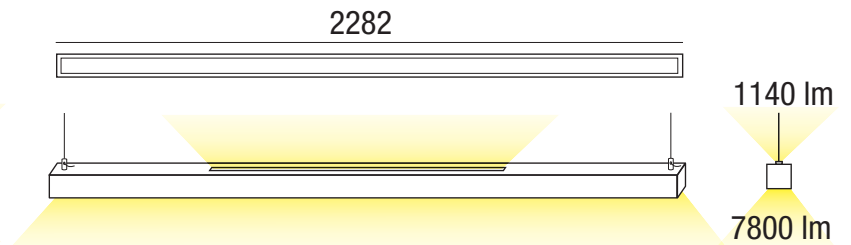
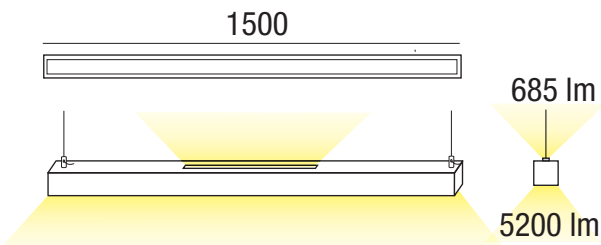
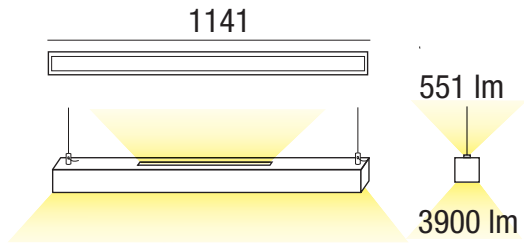

Ceiling/suspended/wall

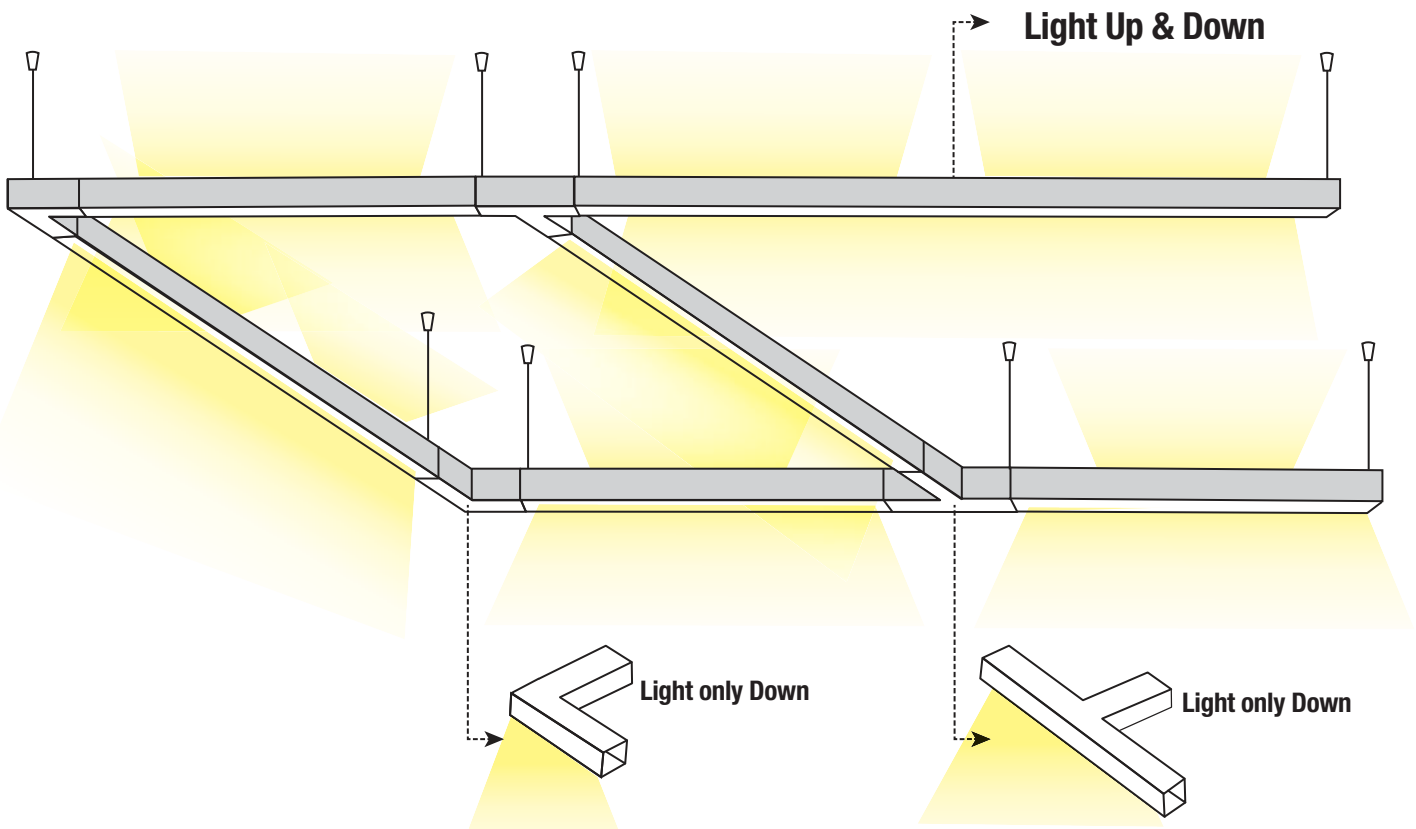



Ceiling/suspended/wall

220  
240V

50/60  
Hz

IK07

IP40

CRI 90

+40  
C°  
-20

850°

CE

DRIVER INCLUDED  
MULTIPOWER

RG0



**KIT Congiunzione a L, luminoso - SOLO SOSPENSIONE**  
**KIT L-shaped angular joint - ONLY SUSPENDED**



15W  
1950 lm

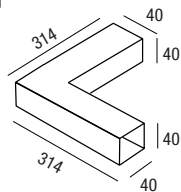

	colour	W max	Vac	lm output	lm/W	K	Kg	CELL
	B	14	220-240	1820	130	3000	0.20	100/3K/SC
	B	14	220-240	1820	130	4000	0.20	100/4K/SC
	<b>DALI 2 PUSH</b> B	14	220-240	1820	130	3000	0.20	100/3K/SCDA
	<b>DALI 2 PUSH</b> B	14	220-240	1820	130	4000	0.20	100/4K/SCDA
	N	14	220-240	1820	130	3000	0.20	100B/3K/SC
	N	14	220-240	1820	130	4000	0.20	100B/4K/SC
	<b>DALI 2 PUSH</b> N	14	220-240	1820	130	3000	0.20	100B/3K/SCDA
	<b>DALI 2 PUSH</b> N	14	220-240	1820	130	4000	0.20	100B/4K/SCDA

**EMER** **Attenzione!** nel caso il progetto venga fatto con sistema DALI+EMER non è possibile utilizzare questo modulo.  
**Attention!** if the project is done with the DALI + EMER system it is not possible to use this module.

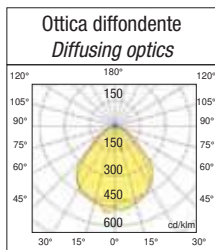

**KIT Congiunzione a T, luminoso - SOLO SOSPENSIONE**  
**KIT T-shaped angular joint - ONLY SUSPENDED**



23W  
2650 lm

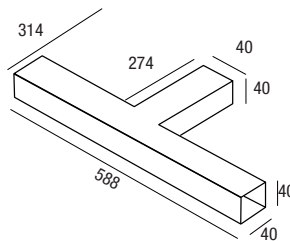

	colour	W max	Vac	lm output	lm/W	K	Kg	CELL
	B	20	220-240	2600	130	3000	0.20	101/3K/SC
	B	20	220-240	2600	130	4000	0.20	101/4K/SC
	<b>DALI 2 PUSH</b> B	20	220-240	2600	130	3000	0.20	101/3K/SCDA
	<b>DALI 2 PUSH</b> N	20	220-240	2600	130	4000	0.20	101/4K/SCDA
	N	20	220-240	2600	130	3000	0.20	101B/3K/SC
	N	20	220-240	2600	130	4000	0.20	101B/4K/SC
	<b>DALI 2 PUSH</b> N	20	220-240	2600	130	3000	0.20	101B/3K/SCDA
	<b>DALI 2 PUSH</b> N	20	220-240	2600	130	4000	0.20	101B/4K/SCDA

**EMER** **Attenzione!** nel caso il progetto venga fatto con sistema DALI+EMER non è possibile utilizzare questo modulo.  
**Attention!** if the project is done with the DALI + EMER system it is not possible to use this module.

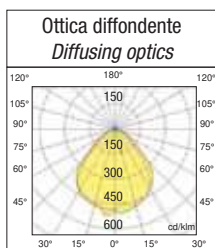

# Sky system accessori - accessories

Accessori a richiesta a sospensione e plafone singole o linea continua  
*Suspension or ceiling accessories single or continuous lines on demand*

## Kit per montaggio a plafone - Ceiling mounting kit

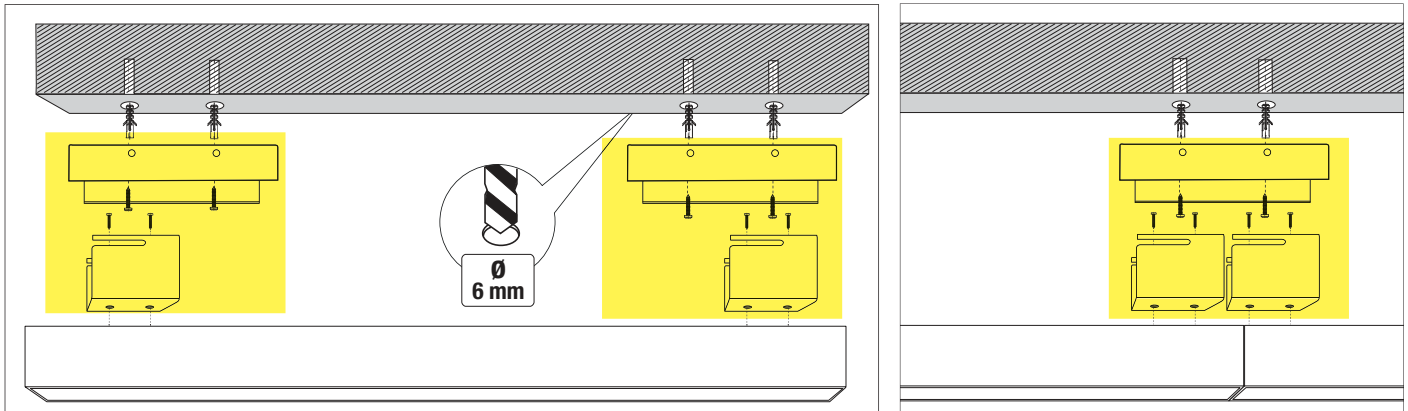

**104R2XSKY** Kit con 2 staffe per montaggio a plafone Sky system 1141mm.  
*2 Sky system ceiling mounting brackets kit 1141mm.*

**104R3XSKY** Kit con 3 staffe per montaggio a plafone Sky system 2282mm.  
*3 Sky system ceiling mounting brackets kit 2282mm.*

Esempio applicativo per montaggio staffe per file continue a plafone.

*Application example for ceiling-mounted continuous lines.*

## Kit di alimentazione - Power supply kit

Colour	Cavo	pcs	Kg	Code
B	3x1,5	1	0,01	102/3/C
B	5x1,5	2	0,01	102/5/C
N	3x1,5	1	0,01	102B/3/C
N	5x1,5	2	0,01	102B/5/C

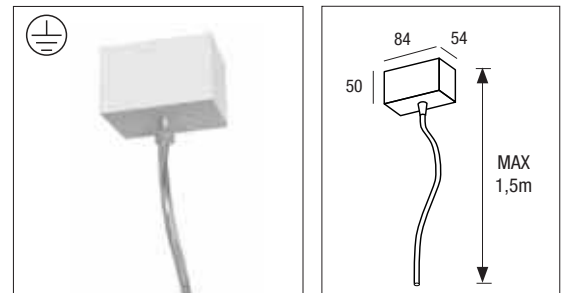

## Kit cavo per sospensione - Suspension cable kit

Colour	pcs	Kg	PCS	Code
B	001	0,250	1 cavo/cable	103/S

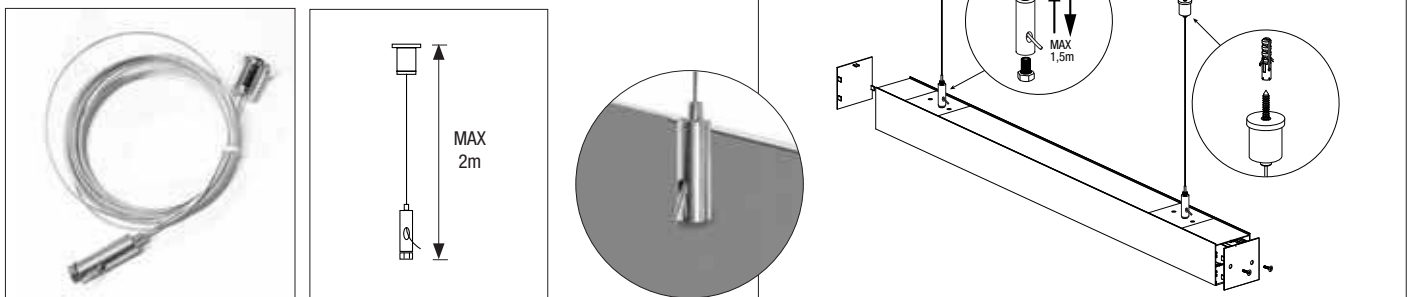

## Kit staffa di giunzione e mascherina per fila continua in sospensione - Joint bracket and mask kit for continuous suspended row

Colour	pcs	Kg	Code
B	1	0,01	100/SL/SKY

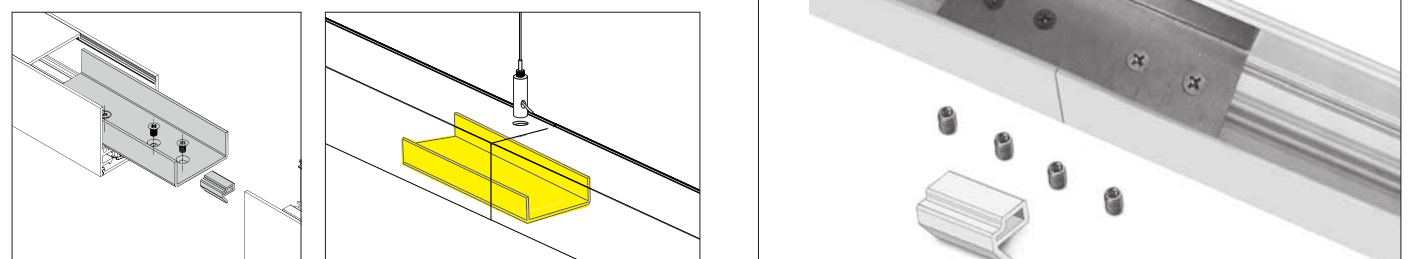

220 240V	50/60 Hz	IK07	IP40	CRI 90	+40 C° -20	850°	CE			DRIVER INCLUDED MULTIPOWER	RG0
RETAIL	MARKET	SCHOOL 1+1=2 ABC	HOTEL	HOSPITAL	OFFICE	GYM	TOILET	EMER	Per lampade cablate in emergenza (aggiungere /EM dopo il codice) sovrapprezzo del 30%. For wired emergency lights (add /EM after the code) 30% extra charge.		



### LED Sky box W.

Appliche di spessore ridotto per, uffici, reception, supermarket, palestre.

**Installazione:** a parete.

**Corpo:** alluminio estruso anodizzato al naturale verniciato (goffrato) a polveri epossidiche bianco RAL 9010 e nero RAL 9005.

**Diffusore:** in policarbonato Opale UGR<19.

**Conforme alla norma:** EN60598-1, RG0 nessun rischio fotobiologico ai fini della norma EN62471.

**Led:** Samsung SMD mantenimento del flusso luminoso minimo al 80% L80B20>50.000h.

**Driver multipotenza:** Incluso > 50.000 h Fattore di potenza ≥0,95.

**Prodotto conforme alle direttive:**

*Wall lamp with reduced thickness for offices, receptions, supermarkets, gyms.*

**Installation:** on wall.

**Body:** natural anodised extruded aluminium painted (Textured) with white RAL 9010 and black RAL 9005 epoxy powders.

**Diffuser:** in opal polycarbonate UGR <19.

**Compliant with standard:** EN60598-1, RG0 no photobiological risk for the purposes mentioned in standard EN62471.

**Led:** Samsung SMD maintenance of 80% minimum luminous flux: L80B20>50.000h.

**Multipower driver:** Included > 50,000 h Power factor ≥0.95.

**Product compliant with directives:**

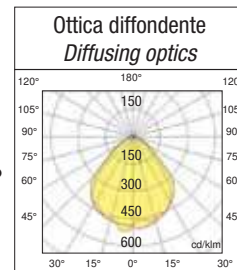
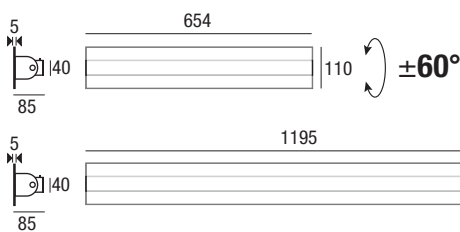

colour	W max	Vac	lm output	lm/W	K	L [mm]	Kg	CELL
B	20	220-240	1950-2600	130	3000	600	1.00	60W3K
B	20	220-240	1950-2600	130	4000	600	1.00	60W4K
B	20	220-240	1950-2600	130	3000	600	1.00	60W3KDA
B	20	220-240	1950-2600	130	4000	600	1.00	60W4KDA
B	20	220-240	2600-3900	130	3000	1141	2.00	114W3K
B	20	220-240	2600-3900	130	4000	1141	2.00	114W4K
B	20	220-240	2600-3900	130	3000	1141	2.00	114W3KDA
B	20	220-240	2600-3900	130	4000	1141	2.00	114W4KDA

**N** A richiesta per quantità versione nera / On request for quantity black version.

Ceiling/suspended/wall

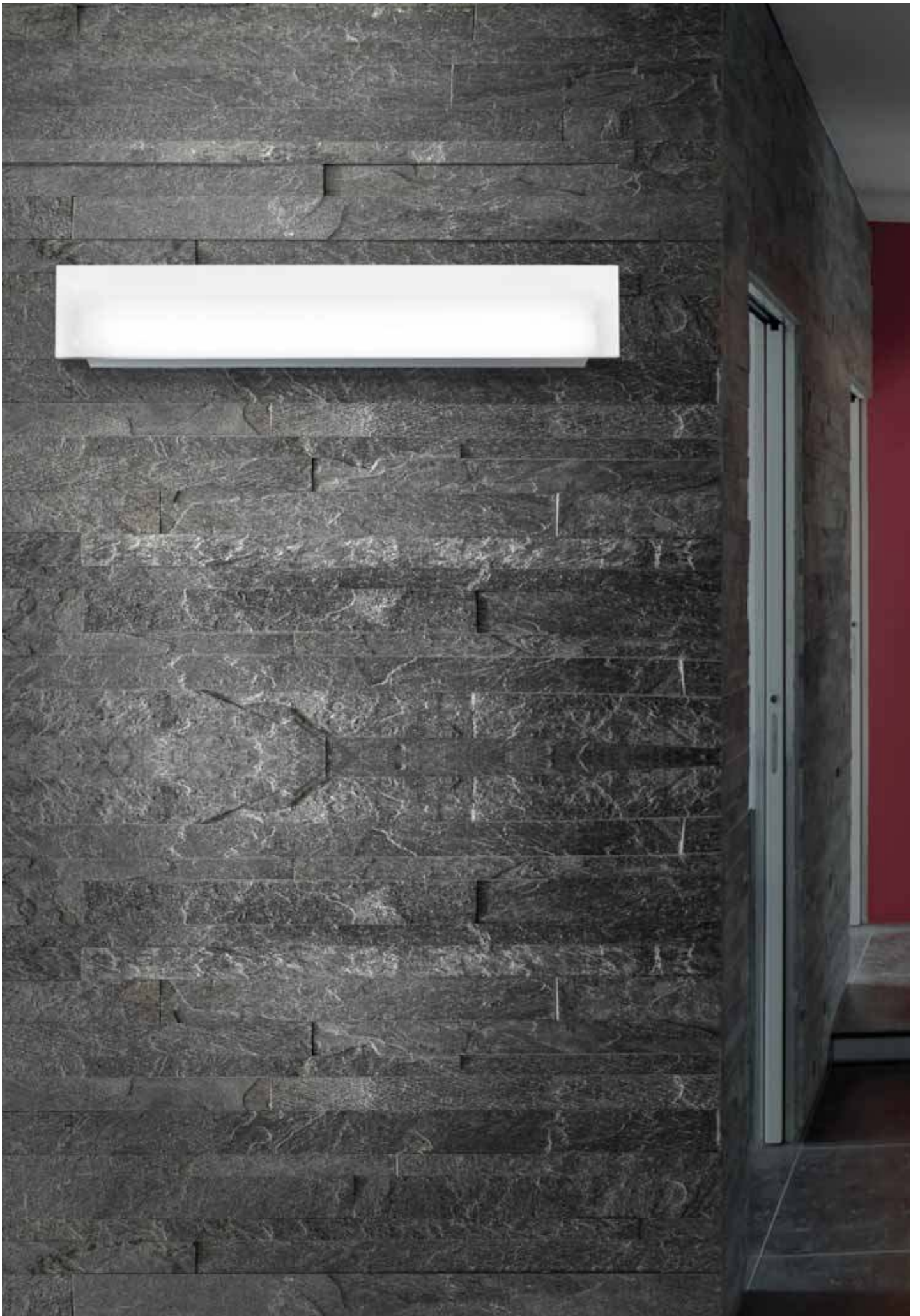

Ceiling/suspended/wall

## Infinity S-C

Apparecchio singolo e fila continua  
Single devices and continuous line

**NEW**

A RICHIESTA  
ON DEMAND

0-10V

DALI 2



WIRELESS

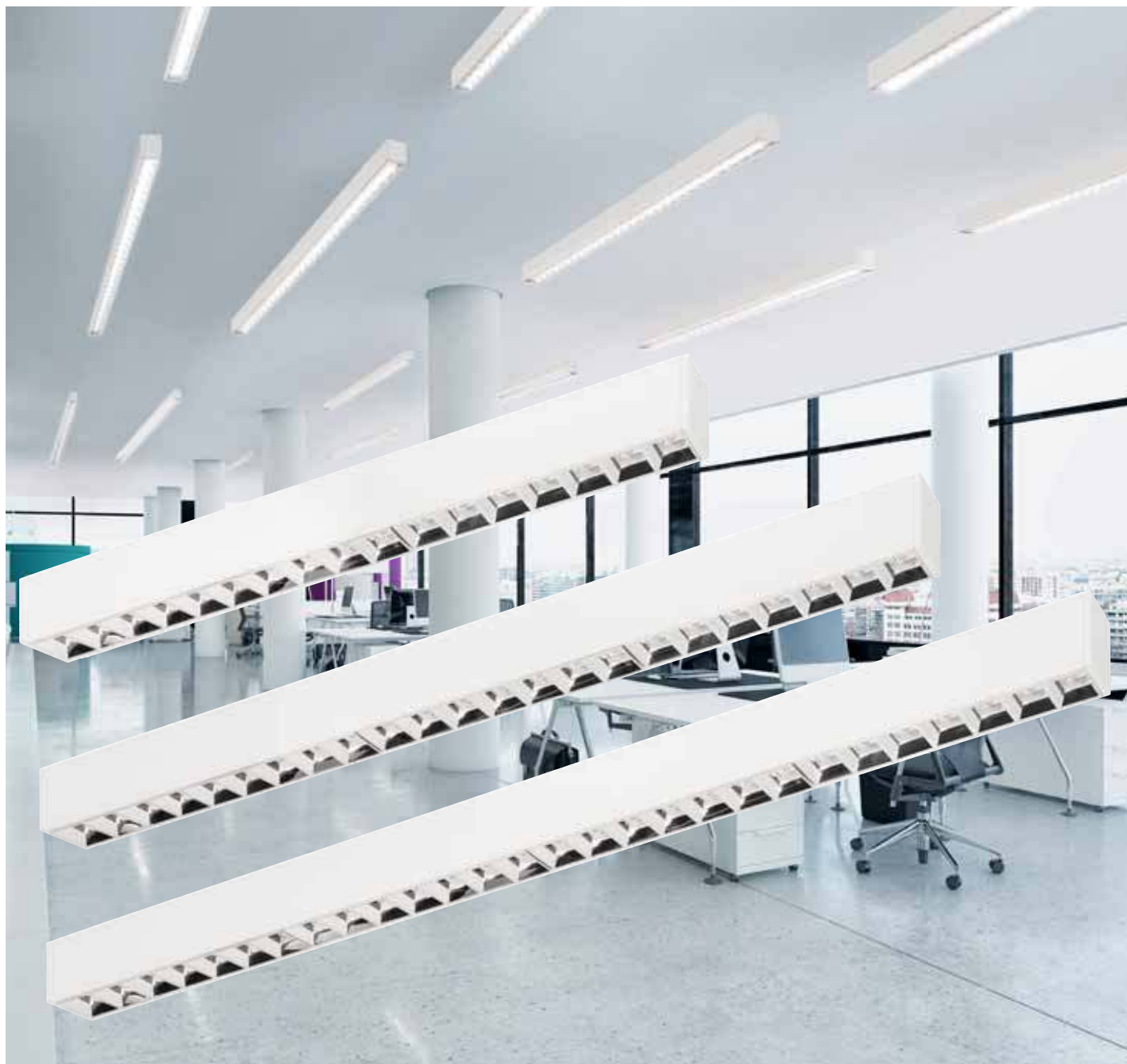

### LED Infinity S-C dark light.

Sistema luminoso modulare per file continue a sospensione o plafone, ideale uffici, reception, supermarket, palestre. Elementi di giunzione di semplice utilizzo per linee continue, la lampada è già predisposta di serie con cablaggio per fila continua.

Collegamento rapido con morsetto fast.

**A richiesta modello Biemissione.**

**Installazione:** a sospensione S e a plafone C con accessori (non inclusi).

**Corpo:** alluminio estruso anodizzato al naturale verniciato (goffrato) a polveri epossidiche bianco RAL 9010 e nero RAL 9005.

**Ottica comfort dark:** simmetrica 65° in policarbonato metallizzato anti-abbagliamento per un miglior confort visivo.

**Conforme alla norma:** EN60598-1, RG0 nessun rischio fotobiologico ai fini della norma EN62471.

**Led:** Lumileds SMD CRI90 mantenimento del flusso luminoso minimo L80B20>50.000h.

**Driver multipotenza:** Incluso > 50.000 h  Fattore di potenza ≥0,95, con dip switch accessibile per poter diminuire i W e di conseguenza i Lm.

**A richiesta:** per quantità si esegue il settaggio dedicato della corrente del Driver e di conseguenza la potenza di W e Lm.

**Prodotto conforme alle direttive:** 

### LED Infinity S-C dark light.

Modular lighting system for continuous lines suspended or ceiling, ideal for offices, receptions, supermarkets, gyms. Easy-to-use connection elements for continuous lines, the lamp is already set up as standard with wiring for continuous lines.

Quick connection with fast terminal.

**On request Bi-emission model.**

**Installation:** suspension S or ceiling C with accessory (included).

**Body:** natural anodised extruded aluminium painted (Textured) with white RAL 9010 and black RAL 9005 epoxy powders.

**Comfort dark optics:** symmetrical 65° in anti-glare metallized polycarbonate for improved visual comfort.

**Compliant with standard:** EN60598-1, RG0 no photobiological risk for the purposes mentioned in standard EN62471.

**Led:** Lumileds SMD CRI90 minimum luminous flux maintenance L80B20>50.000h.

**Multipower driver:** Included > 50,000 h  Power factor ≥0.95, with accessible dip switch to be able to decrease the W and consequently the Lm.

**On request:** for quantity, the dedicated setting of the Driver current and consequently the power of W and Lm is carried out.

**Product compliant with directives:** 

220 240V	50/60 Hz	IK07	IP40	CRI 90	+40 C° -20	850°	CE				DRIVER INCLUDED MULTIPOWER	RG0
RETAIL	MARKET	SCHOOL 1+1=2 ABC	HOTEL	HOSPITAL	OFFICE	GYM	TOILET	EMER	Per lampade cablate in emergenza (aggiungere /EM dopo il codice) sovrapprezzo del 40%. Emergenza non possibile per versioni in linea continua. For wired emergency lights (add /EM after the code) 40% extra charge. Emergency not possible for versions in continuous line.			

### Infinity S-C



Bianco e nero standard, a richiesta consegna 90gg:  
Standard black and white, 90-day delivery on request:

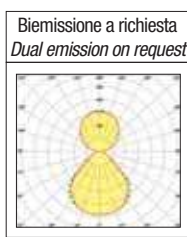
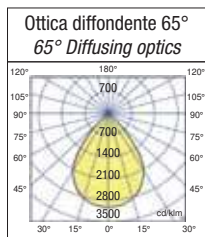

	colour	W max	Vac	lm output	lm/W	K	L <sub>50</sub> [mm]	Kg	CELL
	B	16	220-240	2080	130	3000	578	2.00	653K
	B	16	220-240	2080	130	4000	578	2.00	654K
DALI 2 PUSH	B	16	220-240	2080	130	3000	578	2.00	653KDA
DALI 2 PUSH	B	16	220-240	2080	130	4000	578	2.00	654KDA
	N	16	220-240	2080	130	3000	578	2.00	65B3K
	N	16	220-240	2080	130	4000	578	2.00	65B4K
DALI 2 PUSH	N	16	220-240	2080	130	3000	578	2.00	65B3KDA
DALI 2 PUSH	N	16	220-240	2080	130	4000	578	2.00	65B4KDA
	B	30	220-240	3900	130	3000	1150	2.00	1133K
	B	30	220-240	3900	130	4000	1150	2.00	1134K
DALI 2 PUSH	B	30	220-240	3900	130	3000	1150	2.00	1133KDA
DALI 2 PUSH	B	30	220-240	3900	130	4000	1150	2.00	1134KDA
	N	30	220-240	3900	130	3000	1150	2.00	113B3K
	N	30	220-240	3900	130	4000	1150	2.00	113B4K
DALI 2 PUSH	N	30	220-240	3900	130	3000	1150	2.00	113B3KDA
DALI 2 PUSH	N	30	220-240	3900	130	4000	1150	2.00	113B4KDA
	B	40	220-240	5200	130	3000	1436	4.00	1423K
	B	40	220-240	5200	130	4000	1436	4.00	1424K
DALI 2 PUSH	B	40	220-240	5200	130	3000	1436	4.00	1423KDA
DALI 2 PUSH	B	40	220-240	5200	130	4000	1436	4.00	1424KDA
	N	40	220-240	5200	130	3000	1436	4.00	142B3K
	N	40	220-240	5200	130	4000	1436	4.00	142B4K
DALI 2 PUSH	N	40	220-240	5200	130	3000	1436	4.00	142B3KDA
DALI 2 PUSH	N	40	220-240	5200	130	4000	1436	4.00	142B4KDA

### Sistema biemissione a richiesta - Dual emission system on demand

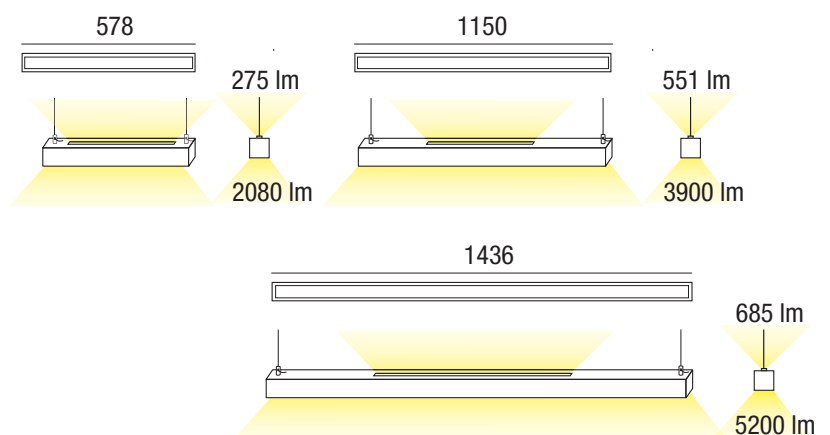
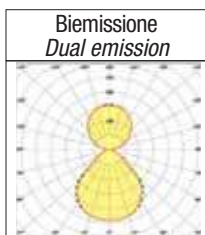

Biemissione con unica accensione, sovrapprezzo del 30% (aggiungere /DM dopo il codice).  
Biemissione con doppia accensione, sovrapprezzo del 40% (aggiungere /2DM dopo il codice).

Bi-emission with single ignition, 30% surcharge (add /DM after the code).  
Bi-emission with double ignition, 40% surcharge (add /2DM after the code).



VIANOLUX

# Infinity s-c accessori - *accessories* a richiesta a sospensione e plafone singole o linea continua *Suspension or ceiling accessoires single or continuous lines on demand*

## Kit per montaggio a plafone - *Ceiling mounting kit*

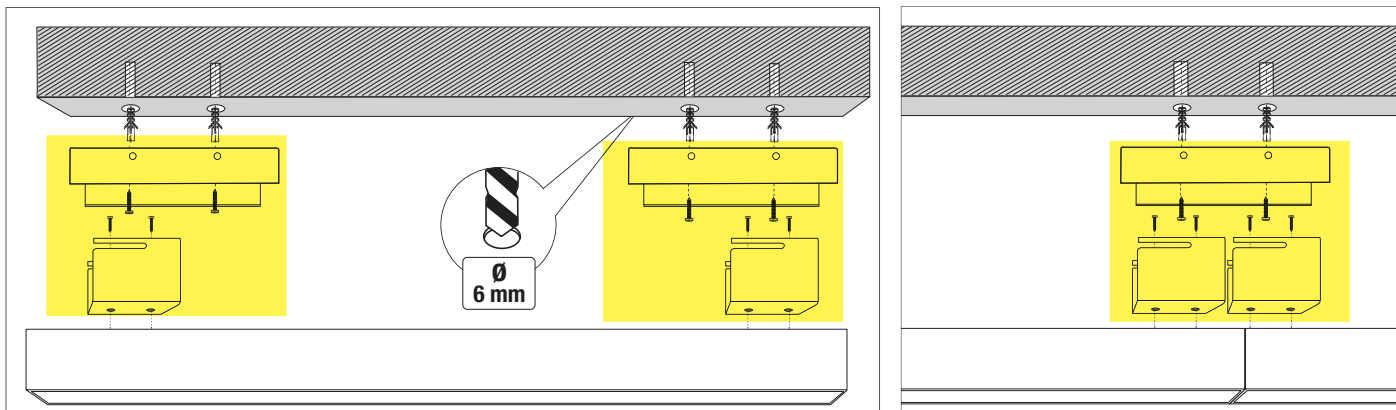

**104R2XINF** Kit con 2 staffe per montaggio a plafone (Infinity 578 mm. - Infinity 1150 mm.).  
*2 ceiling mounting brackets kit (Infinity 578 mm. - Infinity 1150 mm.).*

**104R3XINF** Kit con 3 staffe per montaggio a plafone (Infinity 1436 mm.).  
*3 ceiling mounting brackets kit (Infinity 1436 mm.).*

Esempio applicativo per montaggio staffe per file continue a plafone.  
*Application example for ceiling-mounted continuous lines.*

## Kit di alimentazione - *Power supply kit*

Colour	Cavo	pcs	Kg	Code
B	3x1,5	1	0,01	102/3/C
B	5x1,5	1	0,01	102/5/C
N	3x1,5	1	0,01	102B/3/C
N	5x1,5	1	0,01	102B/5/C

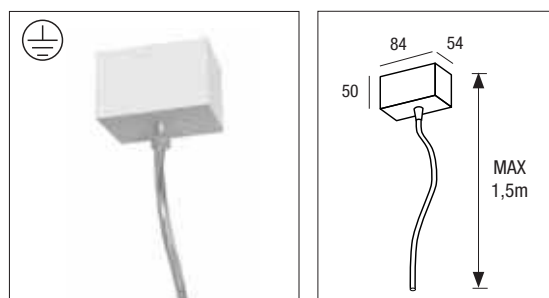

## Kit cavo per sospensione - *Suspension cable kit*

pcs	Kg	PCS	Code
001	0,250	1 cavo/cable	103/S

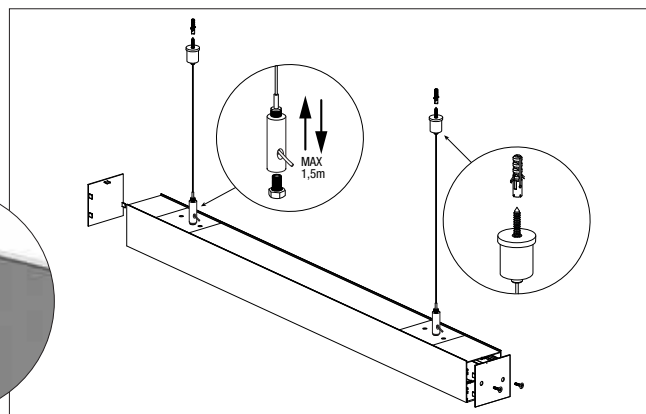
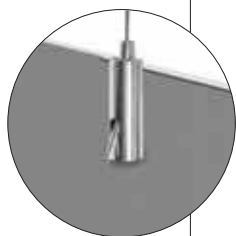
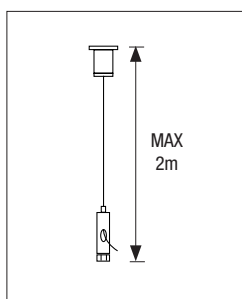

## Kit staffe di giunzione per plafone e sospensione - *Ceiling and suspension connection brackets kit*



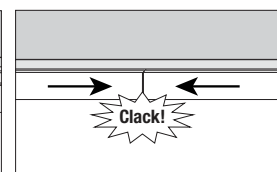
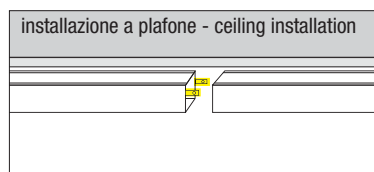
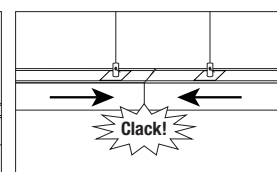
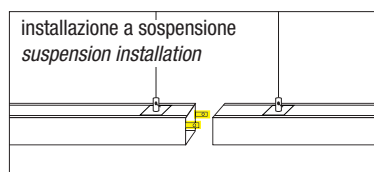

Description	PCS	Code
Kit con 3 staffe di giunzione/ 3 Joint brackets Kit	1	103/ST



# Infinity S-C accessori - *accessories*

## a richiesta Kit montaggio a sospensione per binario trifase

### *Three-phase track suspension mounting kit*

Colour	Cavo	Kg	Infinity L. mm.	Code
B	3x1,5	0,200	655	INFSUSTH65/W
N	3x1,5	0,200	655	INFSUSTH65/B
B	 2	5x1,5	655	INFSUSTH65/WD
N	 2	5x1,5	655	INFSUSTH65/BD
B	3x1,5	0,200	1135	INFSUSTH11/W
N	3x1,5	0,200	1135	INFSUSTH11/B
B	 2	5x1,5	1135	INFSUSTH11/WD
N	 2	5x1,5	1135	INFSUSTH11/BD

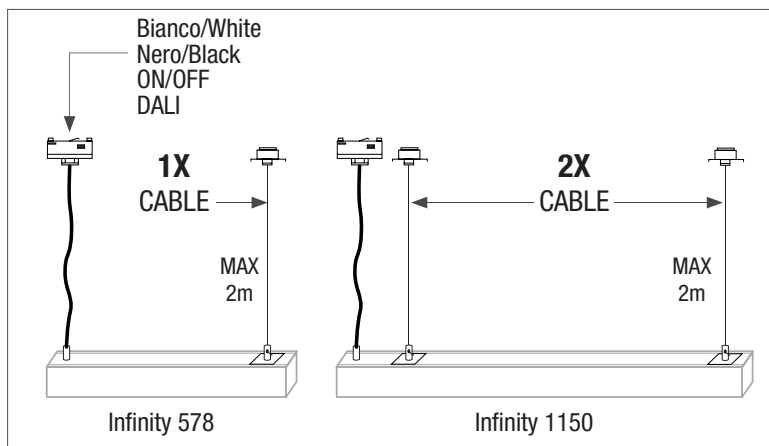

**B**



**N**

Kit accessori per sospendere Infinity S-C su binario trifase, disponibile in 2 colorazioni bianco e nero, composto da:

- Adattatore meccanico con cavo elettrico 2 metri.
- Nippel per sospensione con cavo acciaio 2 metri regolabile in altezza.
- Piastre di aggancio alla lampada.

*Accessories kit for hanging Infinity S-C on a three-phase track, available in 2 colors black and white, consisting of:*

- *Electro-Mechanical adapter with 2 meter electric cable.*
- *Nippel for suspension with 2 meter steel cable adjustable in height.*
- *Plates for attaching to the lamp.*

## Composizioni speciali a richiesta

### *Custom compositions on request*





Ceiling/suspended/wall

100.000 h.

Led SMD 8W  
700mA



Led SMD 10W  
500mA



Led COB 13W  
350mA



Ferma



Beautylight

IP65



Cielo QR



Cielo RR



Gloria RR



Gloria RR trimless



Gloria QR



Gloria QR trimless



Farbtemperatur verfügbar  
Température de couleur disponible



LED-Lichtstrahlöffnung vorhanden  
Ouverture du faisceau lumineux LED disponible

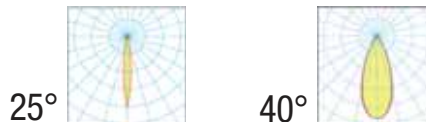

Einbau - Encastré

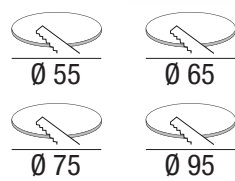

Aria

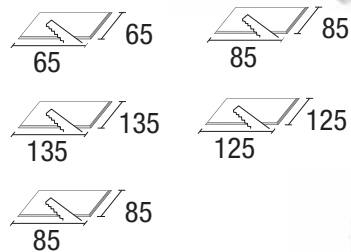

Gessi

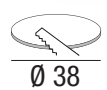

Imperceptible

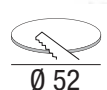

Aqua

Einbau - Encastné

# LED Aria Ultra-Thin

A RICHIESTA  
ON DEMAND

WIRELESS

0-10V

DALI 2



Recessed

LED ARIA, incassi a LED con **design ultra sottile** e ottica arretrata fissa ideale per gli ambienti commerciali, residenziali, nautica, e in qualsiasi ambiente dove è necessaria un'illuminazione spot e d'accento senza abbagliamento.

**Installazione:** incasso a soffitto.

**Corpo:** alluminio pressofuso. Verniciatura, bianco RAL9003 di tipo poliester eseguita a polvere.

**Conforme alla norma:** EN60598-1, RGO nessun rischio fotobiologico ai fini della norma EN62471.

**LED COB:** mantenimento del flusso luminoso minimo al 80%: L80B20>50.000h.

**UGR:** <20

**Driver:** non incluso da ordinare a parte.

*LED ARIA, LED recessed luminaires with ultra-thin design and fixed recessed optics, ideal for commercial, residential, nautical environments and in any environment where glare-free spot and accent lighting is required.*

**Installation:** ceiling recessed.

**Body:** die-cast aluminium. White RAL9003 polyester powder coating.

**According to standard:** EN60598-1, RGO exempt from photo-biological risks in compliance with standard EN62471.

**LED COB:** maintenance of minimum luminous flux to 80%: L80B20>50.000h.

**UGR:** <20

**Driver :** not included, order separately.

36Vdc     IP20 IK04

LED Aria Ultra-Thin

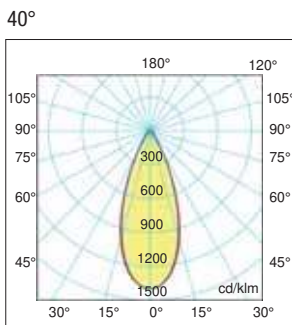
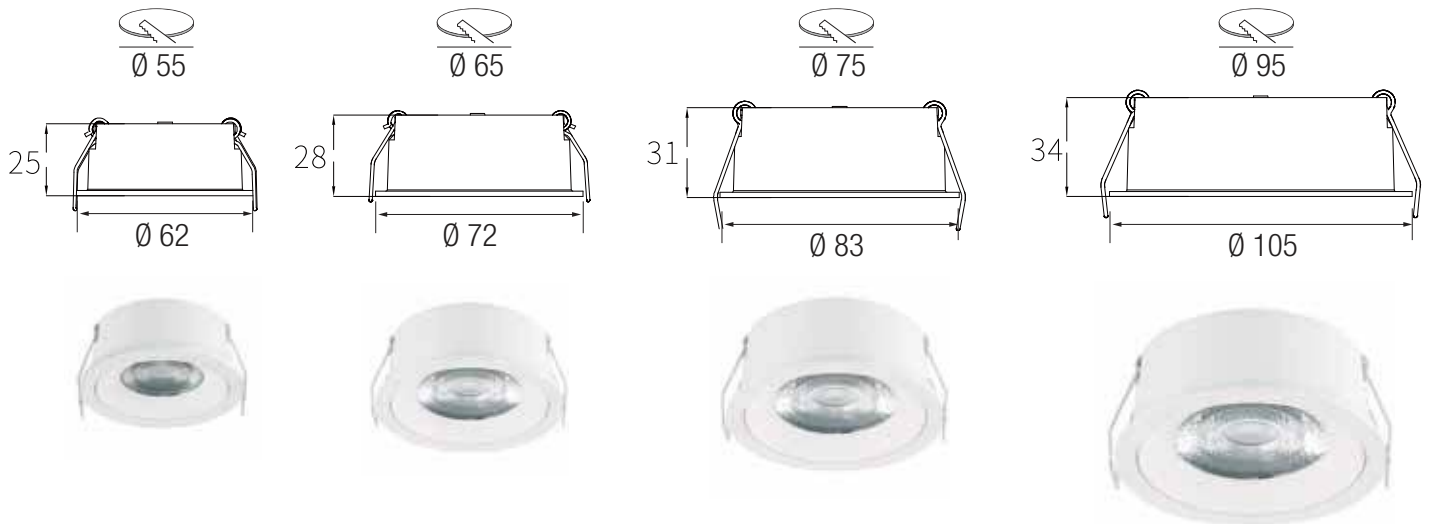

colour	W max	Lm Output		mA max	Vdc	K	pcs	Kg	S+L
[B]	5	575	40°	150	36	3000	048	0,2	ARIA553K5W40
[B]	10	1100	40°	250	36	3000	048	0,25	ARIA653K10W40
[B]	12	1320	40°	300	36	3000	040	0,3	ARIA753K12W40
[B]	15	1650	40°	350	36	3000	036	0,35	ARIA953K15W40

2700 K A richiesta / on demand



**Cod. 7136TB**  
Coprimersetti **NON INCLUSI** (da ordinare a parte RN7136)  
*Terminal cover NOT INCLUDED (ordinarily a part RN7136)*  
Coprimersetti **INCLUSI** (RN7136DA)  
*Terminal cover INCLUDED (RN7136DA)*

# LED Ferma

A RICHIESTA  
ON DEMAND



LED Ferma, incassi a LED con ottica arretrata fissa ideale per gli ambienti commerciali, residenziali e in qualsiasi ambiente dove è necessaria un'illuminazione spot e d'accento senza abbagliamento.

Apparecchi semplici ma efficaci a base tonda o quadra con cornice, ideali per sostituire apparecchi con sorgenti dicroiche da 50W.

**Installazione:** incasso a soffitto

**Corpo:** alluminio pressofuso. Verniciatura, bianco RAL9003 di tipo poliestere eseguita a polvere.

**Conforme alla norma:** EN60598-1, RG0 nessun rischio fotobiologico ai fini della norma EN62471.

**LED:** mantenimento del flusso luminoso minimo al 80%: L80B20>50.000h.

**Driver:** incluso nel Kit.

*LED Ferma, LED Firma, LED series downlighter with fixed optic in rear position, ideal for residential and retail environments, and for any other space that requires accent spot lighting without glare. It is a simple, yet effective fixture with round or square body and frame, ideal to replace luminaires with 50W dichroic lamps.*

**Installation:** ceiling recessed.

**Body:** die-cast aluminium. White RAL9003 polyester powder coating.

**According to standard:** EN60598-1, RG0 exempt from photo-biological risks in compliance with standard EN62471.

**LED:** maintenance of minimum luminous flux to 80%: L80B20>50.000h.

**Driver:** included in Kit.

220-240V 50/60Hz

## LED Ferma



Led SMD 8W

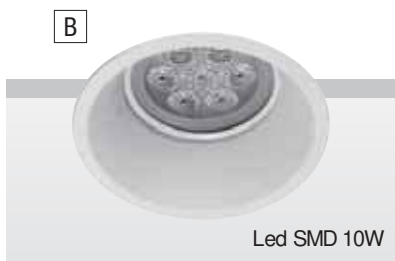

Led SMD 10W



Led COB 13W

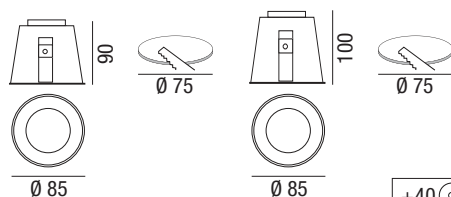

8W - 10W

13W



colour	W max	Lm Output	Beam	mA max	K	pcs	Kg	CELL
[B]	8	800	wide	700	3000	001	0,314	30779/WNAP
	8	800	wide	700	3000	001	0,314	30779/WNAPDA
[B]	8	800	wide	700	4000	001	0,314	30779/WNAP4K
	8	800	wide	700	4000	001	0,314	30779/WNAP4KD
[B]	10	1050	40°	500	4000	001	0,314	30777/W/4K
[B]	10	1050	40°	500	3000	001	0,314	30779/W
	10	1050	40°	500	3000	001	0,314	30779/W/DALI
[B]	13	1400	medium	350	3000	001	0,314	30777/W/V10
[B]	13	1400	wide	350	3000	001	0,314	30779/W/V10
	13	1400	wide	350	3000	001	0,314	30779/W/V10DA
[B]	13	1400	wide	350	4000	001	0,314	30779WV104K
	13	1400	wide	350	4000	001	0,314	30779WV104KDA

2700 K A richiesta / on demand

## Dati fotometrici - Photometric data

Medium

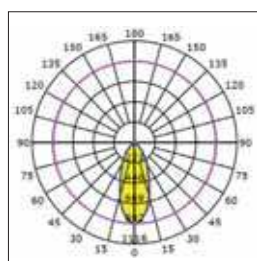

Wide

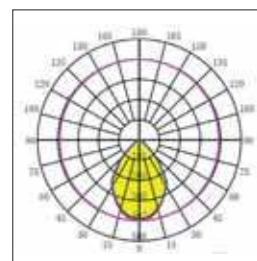

40°

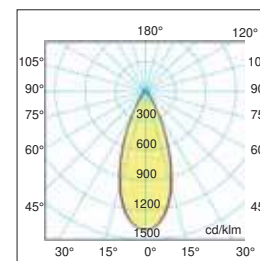



## LED Cielo QR - RR -3RR



Recessed

Incassi a LED con frontali antiabbagliamento in varie finiture sostituibili a piacere, vista la facile installazione.

Ideale per un'illuminazione piacevole ed omogenea in strutture pubbliche, uffici, Hotel e reparti wellness, oppure negozi e centri commerciali, se montato in soffitti chiusi, il downlight raggiunge la protezione IP44 e quindi può essere montato in zone più critiche.

**Installazione:** incasso a soffitto.

**Corpo:** alluminio pressofuso. Verniciatura di tipo poliestere eseguita a polvere bianco RAL9010.

**Ottica:** arretrata direzionabile  $\pm 15^\circ$ .

**Conforme alla norma:** EN60598-1, RG0 nessun rischio fotobiologico ai fini della norma EN62471.

**LED:** mantenimento del flusso luminoso minimo al 80%: L90B10>100.000h.

**Driver:**  incluso nel Kit.

*LED recessed luminaires with anti-glare fronts in various finishes that can be replaced at will, given the easy installation.*

*Ideal for pleasant and homogeneous lighting in public buildings, offices, hotels and wellness departments, or shops and shopping centres, if mounted in closed ceilings, the downlight achieves IP44 protection and therefore can be mounted in more critical areas.*

**Installation:** ceiling recessed

**Body:** die-cast aluminium. Polyester powder coating White RAL 9010.

**Optics:** set back, adjustable  $\pm 15^\circ$ .

**According to standard:** EN60598-1, RG0 exempt from photo-biological risks in compliance with standard EN62471.

**LED:** maintenance of minimum luminous flux to 80%: L90B10>100.000h.

**Driver:**  included in Kit.

# LED Cielo QR - RR -3RR



## Accessori non inclusi - Accessories not included

Frontali antiabbagliamento disponibile in vari colori e finiture.  
Anti-glare panels available in various colours and finishes.



**cod. 48000**  
**orientabile/orientable**  
Bianco opaco  
*Matt White*



**cod. 48001**  
**orientabile/orientable**  
Nero opaco  
*Matt black*



**cod. 48002**  
**orientabile/orientable**  
Argento sabbiato  
*Sandy Silver*



**cod. 48003**  
**orientabile/orientable**  
Cromo nero UV lucido  
*UV Black chrome*



**cod. 48004**  
**orientabile/orientable**  
Cromo lucido UV  
*UV polished chrome*



**cod. 48005**  
**orientabile/orientable**  
Oro lucido UV  
*UV polished Gold*



**cod. 48006**  
**orientabile/orientable**  
Rame lucido UV  
*UV polished Copper*

## Sorgente luminosa e frontali antiabbagliamento a scelta - Choice of light source and anti-glare fronts

8W - 10W - 13W  
2700K-3000K-4000K  
LED SMD - LED COB

7W 3CCT -700Lm/W  
3000-4000-6000K  
GU10 230V.

8W - 10W - 13W  
2700K-3000K-4000K  
LED SMD - LED COB

7W 3CCT -700Lm/W  
3000-4000-6000K  
GU10 230V.



Riflettore da ordinare a parte  
*Reflector to be ordered separately*

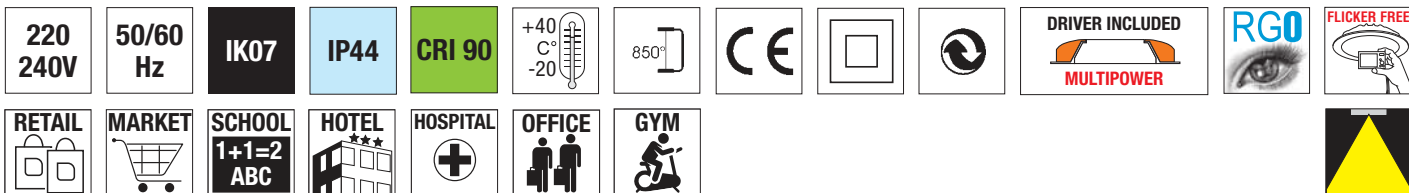

### LED Cielo QR

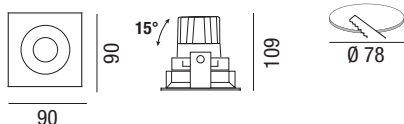

	W max	Lm Output	Beam Angle	K	pcs	Kg	S+L			
B	7	Led GU10	700	36°	3000	4000	6000	001	0,314	48009GU103CCT *

\* Q.tà minima 20 pcs - Minimum quantity 20 pcs

	W max	Lm Output	Beam Angle	mA max	K	pcs	Kg	CELL
B	8	880	medium	700	3000	001	0,314	48009NAPO
B	8	880	medium	700	4000	001	0,314	48010NAPO
DALI 2 PUSH B	8	880	medium	700	3000	001	0,314	48009DALNAPO
DALI 2 PUSH B	8	880	medium	700	4000	001	0,314	48010DALNAPO
B	10	1100	40°	500	3000	001	0,314	48009/3K
B	10	1100	40°	500	4000	001	0,314	48010/4K
DALI 2 PUSH B	10	1100	40°	500	3000	001	0,314	48009DALI
DALI 2 PUSH B	10	1100	40°	500	4000	001	0,314	48010DALI
B	13	1430	medium	350	3000	001	0,314	48011/3K
B	13	1430	medium	350	4000	001	0,314	48012/4K
DALI 2 PUSH B	13	1430	medium	350	3000	001	0,314	48011DALI
DALI 2 PUSH B	13	1430	medium	350	4000	001	0,314	48012DALI

2700 K A richiesta / on demand

### LED Cielo RR

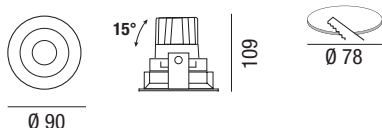

	W max	Lm Output	Beam Angle	K	pcs	Kg	S+L			
B	7	Led GU10	700	36°	3000	4000	6000	001	0,314	49009GU103CCT *

\* Q.tà minima 20 pcs - Minimum quantity 20 pcs

	W max	Lm Output	Beam Angle	mA max	K	pcs	Kg	CELL
B	8	880	medium	700	3000	001	0,314	49009NAPO
B	8	880	medium	700	4000	001	0,314	49010NAPO
DALI 2 PUSH B	8	880	medium	700	3000	001	0,314	49009DALNAPO
DALI 2 PUSH B	8	880	medium	700	4000	001	0,314	49010DALNAPO
B	10	1100	40°	500	3000	001	0,314	49009/3K
B	10	1100	40°	500	4000	001	0,314	49010/4K
DALI 2 PUSH B	10	1100	40°	500	3000	001	0,314	49009DALI
DALI 2 PUSH B	10	1100	40°	500	4000	001	0,314	49010DALI
B	13	1430	medium	350	3000	001	0,314	49011/3K
B	13	1430	medium	350	4000	001	0,314	49011/4K
DALI 2 PUSH B	13	1430	medium	350	3000	001	0,314	49011DALI
DALI 2 PUSH B	13	1430	medium	350	4000	001	0,314	49012DALI

2700 K A richiesta / on demand

# LED Cielo 3RR

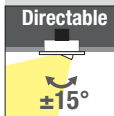
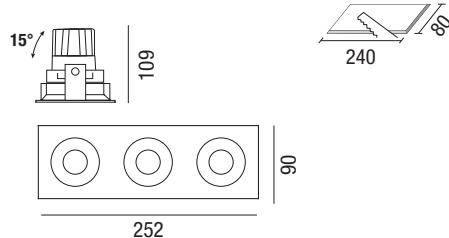

	W max		Lm Output		K	pcs	Kg	S+L
B	3x7	Led GU10	700	36°	3000 4000 6000	001	0,314	38009GU103CCT *

\* Q.tà minima 20 pcs - Minimum quantity 20 pcs

	W max	Lm Output		mA max	K	pcs	Kg	CELL
B	3x8	3x880	medium	700	3000	001	0,900	38009NAPO
B	3x8	3x880	medium	700	4000	001	0,900	38010NAPO
	B	3x8	3x880	medium	700	3000	001	38009DALNAPO
	B	3x8	3x880	medium	700	4000	001	38010DALNAPO
B	3x10	3x1100	40°	500	3000	001	0,900	38009/3K
B	3x10	3x1100	40°	500	4000	001	0,900	38010/4K
	B	3x10	3x1100	40°	500	3000	001	38009DALI
	B	3x10	3x1100	40°	500	4000	001	38010DALI
B	3x13	3x1430	medium	350	3000	001	0,900	38011/3K
B	3x13	3x1430	medium	350	4000	001	0,900	38012/4K
	B	3x13	3x1430	medium	350	3000	001	38011DALI
	B	3x13	3x1430	medium	350	4000	001	38012DALI

2700 K A richiesta / on demand

## Tabella di scelta potenza driver LED (incluso) - LED Power supply table choice (included)



Fornito di dip switch per la selezione della tensione in uscita. Il driver incluso nella confezione è normalmente settato alla massima corrente. Se necessario è possibile diminuire la potenza e di conseguenza i lumen output.

Equipped with dip switch for selecting the voltage output. The driver included inside the package is usually set to max power. If necessary it is possible to decrease the power and consequently the lumen output.

## Esempio applicativo Cielo 13W - Cielo 13W application example

Taratura - Dip-switch	Potenza - Power
mA	Watt
200	7
250	9
300	11
350	13
Taratura standard di fabbrica Driver Standard factory setting	

## Dati fotometrici - Photometric data

Medium standard / standard

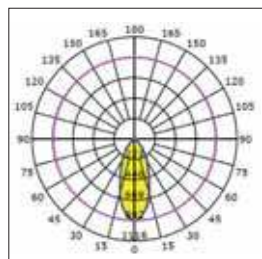

Wide a richiesta / on demand

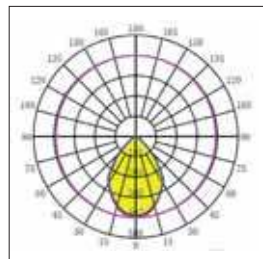

**Cod. 65151LED80CP3**  
Kit emergenza 3W - 3h/12% 180÷250 Vac  
180÷250 Vac - 3h/12% - 3W emergency kit

**Cod. RP0714CP3 - AUTOTEST**  
Kit emergenza 3W - 3h/12% 180÷250 Vac  
180÷250 Vac - 3h/12% - 3W emergency kit

## LED Intrepido 3CCT

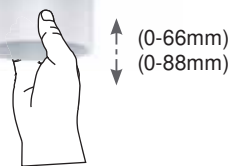

Downlight dal design allungato utilizza una sorgente luminosa COB ad alta luminosità, lo speciale design della lente ottica e del riflettore offre un'emissione luminosa uniforme e un effetto antiabbagliamento ridotto.

Il corpo lampada può essere estratto a piacere e ruotato orizzontalmente di 350 gradi e basculato di  $\pm 20$  gradi per soddisfare le esigenze di illuminazione di più applicazioni. Il modulo ad incasso profondo riduce l'abbagliamento e offre un'esperienza visiva confortevole. possibilità di scelta della temperatura 3CCT con regolazione tramite un dip switch integrato con interruttore a scorrimento.

**Rotazione:** orizzontale di 350 gradi e verticale di 20 gradi.

**Corpo:** in alluminio AL6063 con ottima gestione termica.

**Verniciatura:** di tipo poliestere eseguita a polvere bianco RAL9016, nero RAL 9005.

**Installazione:** incasso a soffitto.

**Ottica:** estraibile totalmente.

**Conforme alla norma:** EN60598-1, RG0 nessun rischio fotobiologico ai fini della norma EN62471.

**LED:** mantenimento del flusso luminoso minimo al 80%: L80B20 > 50.000h.

**Driver:** non incluso.

*This elongated Downlight uses a high-brightness COB light source. The special design of the optical lens and reflector provides uniform light output and reduced glare.*

*The lamp body can be freely extended and rotated horizontally 350 degrees and tilted  $\pm 20$  degrees to meet the lighting needs of multiple applications. The deep recessed module reduces glare and offers a comfortable viewing experience. 3CCT color temperature selection is available via an integrated dip switch with a slider.*

**Rotation:** 350 degrees horizontally and 20 degrees vertically.

**Body:** AL6063 aluminum with excellent thermal management.

**Coating:** polyester powder coating, white RAL9016, black RAL9005.

**Installation:** recessed ceiling.

**Optic:** fully extendable.

**According to standard:** EN60598-1, RG0, no photobiological risk according to standard EN62471.

**LED:** Minimum luminous flux maintenance at 80%: L80B20 > 50,000h.

**Driver:** not included.

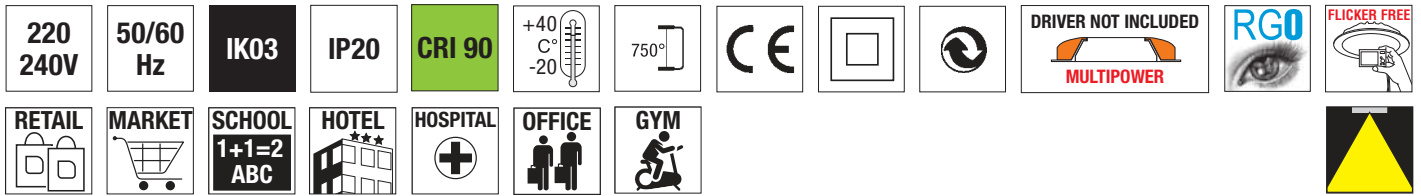

**LED intrepido 3CCT - white**

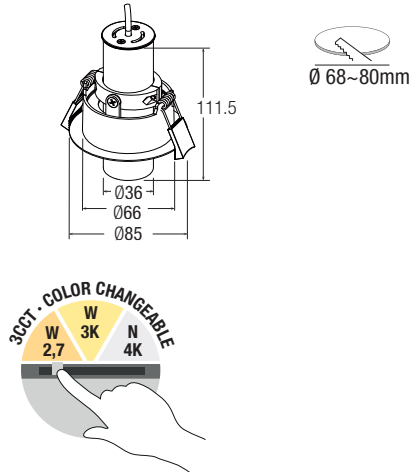

**LED intrepido 3CCT - Black**



	W max		mA	Lm output		K	pcs	Kg	S+L
<b>B</b>	6	COB	150	540~620	36°	2700 3000 4000	001	0,37	INT6WWH36R3CT
<b>N</b>	6	COB	150	540~620	36°	2700 3000 4000	001	0,37	INT6WBL36R3CT

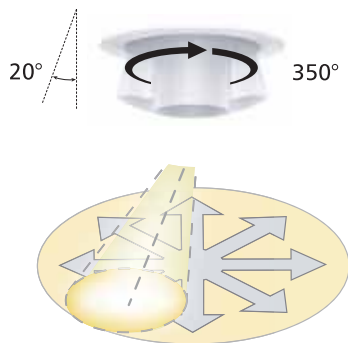
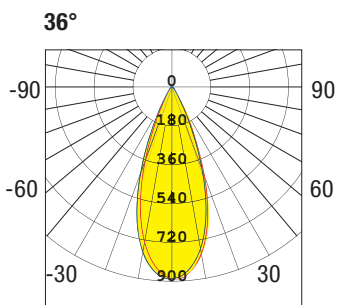

**Scelta driver LED (non incluso) - LED Power supply choice (not included)**



**RN7136**  
Coprimerzetti NON INCLUSI  
Terminal cover NOT INCLUDED

**RN7136DA**  
Coprimerzetti INCLUSI  
Terminal cover INCLUDED



**Cod. 65151LED80CP3**  
Kit emergenza 3W - 3h/12% 180÷250 Vac  
180÷250 Vac - 3h/12% - 3W emergency kit

**Cod. RP0714CP3 - AUTOTEST**  
Kit emergenza 3W - 3h/12% 180÷250 Vac  
180÷250 Vac - 3h/12% - 3W emergency kit

## LED Beautylight IP65

A RICHIESTA  
ON DEMAND

0-10V

DALI 2



Faretto LED ad incasso in alluminio pressofuso con diverse finiture con schermo in vetro satinato, grado IP65. Idoneo per applicazioni in zone umide, ottimo il suo utilizzo in centri benessere, laddove si necessiti di un grado IP elevato.

**Installazione:** incasso a soffitto.

**Corpo:** alluminio pressofuso.

**Orientabilità:** fisso.

**Verniciatura:** di tipo poliesteri, eseguita a polvere bianco RAL 9010.

**Cablaggio:** rapido, come da foto.

**Conforme alla norma:** EN60598-1, RG0 nessun rischio fotobiologico ai fini della norma EN62471.

**Led:** mantenimento del flusso luminoso minimo al 80%: L80B20>50.000h.

**Driver:**  incluso nel Kit.

*Recessed LED spotlight in die cast aluminium with different finishes with satin-finish glass screen, protection rating IP65. Suitable for applications in humid areas, ideal for use in well-being facilities, requiring a high IP rating.*

**Installation:** ceiling recessed.

**Body:** die cast aluminium.

**Adjustable:** Fix

**Coating:** coated with powder polyester white RAL 9010.

**Wiring:** fast, like a photo.

**According to standard:** EN60598-1, RG0 exempt from photo-biological risks in compliance with standard EN62471.

**Led:** maintenance of minimum luminous flux to 80%: L80B20>50.000h.

**Driver:**  included in Kit.

220-240V 50/60Hz      **IK07** **IP65**

**Kit LED Beautylight - FIX**

**IP65**

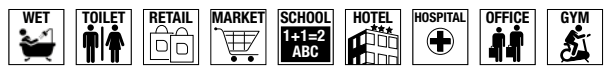
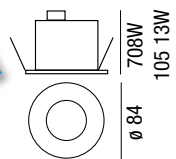

**CRI 90**

**DRIVER INCLUDED**  
**MULTIPOWER**



colour	W max		mA	Lm	K	pcs	Kg	CELL
<b>B</b>	8	medium	700	880	3000	010	0.60	30611NAP0
<b>B</b>	8	medium	700	880	4000	010	0.60	30611NAP0-4K
<b>B</b>	13	medium	350	1430	3000	010	0.60	30611/VL
<b>DALI 2 PUSH</b> <b>B</b>	8	medium	700	880	3000	010	0.60	30611NAP0DA
<b>DALI 2 PUSH</b> <b>B</b>	13	medium	350	1430	3000	010	0.60	30611/VLDA
<b>B</b>	13	medium	700	1430	4000	010	0.60	30611/VL-4K

**2700 K** A richiesta / on demand

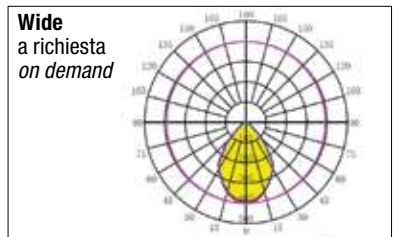
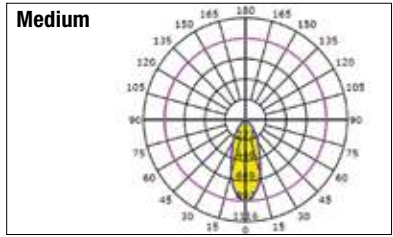

**Recessed**

## LED Gloria RR

A RICHIESTA  
ON DEMAND

0-10V



### Accessori non inclusi - Accessories not included

Frontali antiabbagliamento disponibile in vari colori e finiture.  
Anti-glare panels available in various colours and finishes.



**cod. 45000**  
**fisso/fix**  
Bianco satinato  
Frosted White



**cod. 45001**  
**fisso/fix**  
Nero satinato  
Frosted Black



**cod. 46001**  
**orientabile/orientable**  
Bianco satinato  
Frosted White



**cod. 46002**  
**orientabile/orientable**  
Nero satinato  
Frosted Black



**cod. 46003**  
**orientabile/orientable**  
Argento a specchio  
Mirror-finish silver



**cod. 46004**  
**orientabile/orientable**  
Oro satinato  
Frosted Gold



**cod. 46005**  
A filo muro  
Trimless



**cod. 46006**  
**Semi asimmetrico**  
solo LED COB 13W  
**Semi asymmetric**  
LED COB 13W only

Cod.46006

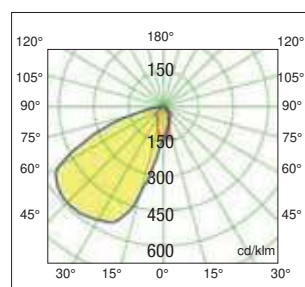

**cod. 46011**  
**Semi concentrante**  
solo LED COB 13W  
**Semi-concentrating**  
LED COB 13W only

Cod.46011

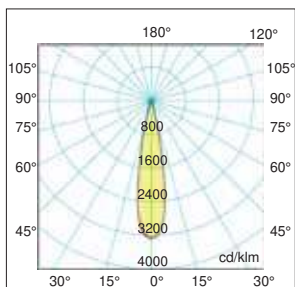

Montaggio a filo senza cornice da  
abbinare ai frontali antiabbagliamento.  
Trimless flush mounting to be  
combined with Anti-glare panels



cod. 45000  
cod. 45001  
cod. 46001  
cod. 46002  
cod. 46003  
cod. 46004  
cod. 46006  
cod. 46011

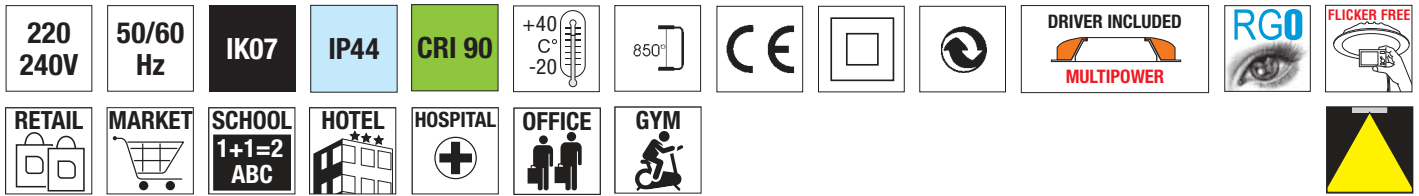

LED Gloria, downlight con frontale antiabbagliamento per installazioni ad incasso, con ottica arretrata orientabile  $\pm 30^\circ$  asse verticale e  $355^\circ$  sull'asse frontale. Ideale per gli ambienti commerciali, residenziali e in qualsiasi ambiente dove è necessaria un'illuminazione spot e d'accento senza abbagliamento. Frontale antiabbagliamento disponibile in differenti colori. Corpo del prodotto realizzato in pressofusione di alluminio verniciato con tecnica powder coating e polveri con elevato grado di purezza. L'ottica speciale permette la creazione della distribuzione rettangolare della luce. La gamma si compone di prodotti con sistema di fissaggio tramite molle piatte, oppure in versione trimless per rasatura in cartongesso.

**Installazione:** incasso a soffitto.

**Corpo:** alluminio pressofuso. Verniciato bianco (RAL 9003) con tecnica powder coating e polveri con elevato grado di purezza.

**Riflettore (non incluso):** in PC placcato in alluminio antiabbagliamento, disponibile in differenti colori.

**Conforme alla norma:** EN60598-1, RGO nessun rischio fotobiologico ai fini della norma EN62471.

**LED COB:** mantenimento del flusso luminoso minimo al 80%: L80B20>50.000h.

**Driver:** incluso.

**Prodotto conforme alle direttive:**

*Gloria LED, downlight with anti-glare panel for flush mounting installations, with recessed adjustable optics  $\pm 30^\circ$  vertical axis and  $255^\circ$  on the front axis, ideal for commercial and residential rooms and in any room where spot and accent lighting without glare is required. Anti-glare panel available in various colours.*

*Product body made of die-cast aluminium painted via powder coating technique and powders with a high degree of purity.*

*The special optics create a rectangular light distribution.*

*The range consists of products with a fixing system using flat springs, or in the trimless version for plasterboard finishing.*

**Installation:** ceiling flush mounting.

**Body:** die-cast aluminium. White painted (RAL 9003) with powder coating technique and powders with a high degree of purity.

**Reflector (not included):** in anti-glare aluminium plated PC, available in various colours. **Compliant with standard:** EN60598-1, RGO no photobiological risk for the purposes mentioned in standard EN62471.

**COB LED:** maintenance of 80% minimum luminous flux: L80B20>50.000h.

**Driver:** included.

**Product compliant with directives:**

### LED Gloria RR

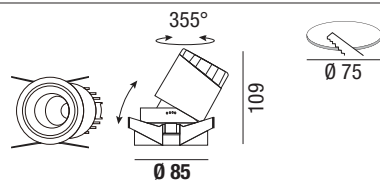
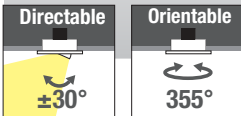

### LED Gloria Trimless

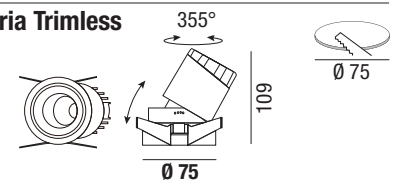

	W max	Lm Output		mA max	K	pcs	Kg	CELL
B	8	800	wide	700	3000	001	0,314	46009NAPO
B	8	800	wide	700	4000	001	0,314	46010NAPO
B	8	800	wide	700	3000	001	0,314	46009DALNAPO
B	8	800	wide	700	4000	001	0,314	46010DALNAPO
B	13	1400	medium	350	3000	001	0,314	46007
B	13	1400	medium	350	4000	001	0,314	46008
B	13	1400	wide	350	3000	001	0,314	46009
B	13	1400	wide	350	4000	001	0,314	46010
B	13	1400	wide	350	3000	001	0,314	46009DALI
B	13	1400	wide	350	4000	001	0,314	46010DALI

2700 K A richiesta / on demand

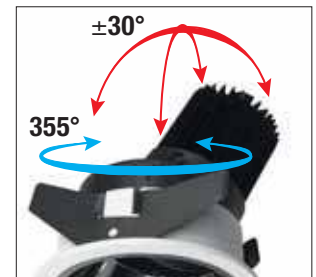

### Tabella di scelta potenza driver LED (incluso) - LED Power supply table choice (included)



### Dati fotometrici - Photometric data

#### Medium

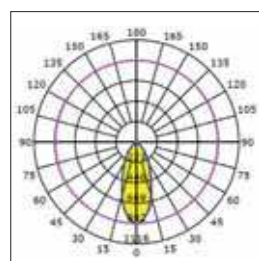

#### Wide

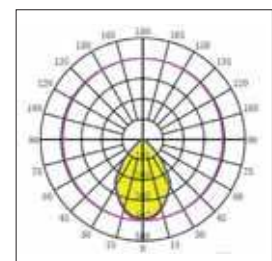

Fornito di dip switch per la selezione della tensione in uscita. Il driver incluso nella confezione è normalmente settato alla massima corrente. Se necessario è possibile diminuire la potenza e di conseguenza i lumen output.

*Equipped with dip switch for selecting the voltage output. The driver included inside the package is usually set to max power. If necessary it is possible to decrease the power and consequently the lumen output.*

## LED Gloria QR

A RICHIESTA  
ON DEMAND

0-10V



LED Gloria Q

LED Gloria Q trimless



### Accessori non inclusi - Accessories not included

Frontali antiabbagliamento disponibile in vari colori e finiture.  
*Anti-glare panels available in various colours and finishes.*

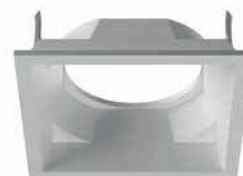

**cod. 47015**  
Bianco satinato  
*Frosted White*



**cod. 47014**  
Nero satinato  
*Frosted Black*



**cod. 47013**  
Argento a specchio  
*Mirror-finish silver*



**cod. 47012**  
Semi concentrante  
*Semi-concentrating*



**cod. 47011**  
A filo muro  
*Trimless*

Montaggio a filo senza cornice da  
abbinare ai frontali antiabbagliamento.  
*Trimless flush mounting to be  
combined with Anti-glare panels*



cod. 47012  
cod. 47013  
cod. 47014  
cod. 47015

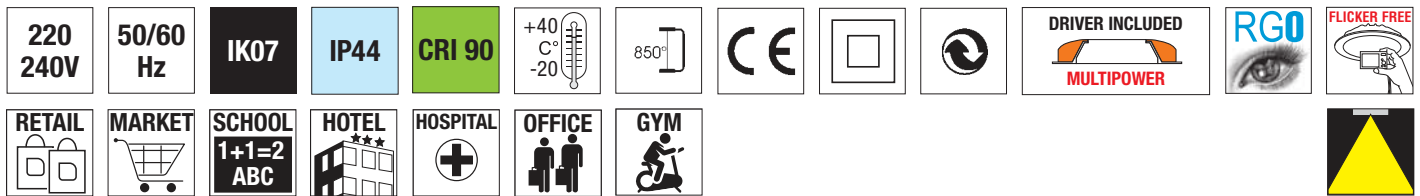

LED Gloria, downlight with frontale antiabbagliamento per installazioni ad incasso, con ottica arretrata orientabile  $\pm 30^\circ$  asse verticale e  $355^\circ$  sull'asse frontale, ideale per gli ambienti commerciali, residenziali e in qualsiasi ambiente dove è necessaria un'illuminazione spot e d'accento senza abbagliamento. Frontale antiabbagliamento disponibile in differenti colori. Corpo del prodotto realizzato in pressofusione di alluminio verniciato con tecnica powder coating e polveri con elevato grado di purezza. L'ottica speciale permette la creazione della distribuzione rettangolare della luce. La gamma si compone di prodotti con sistema di fissaggio tramite molle piatte, oppure in versione trimless per rasatura in cartongesso.

**Installazione:** incasso a soffitto.

**Corpo:** alluminio pressofuso. Verniciato bianco (RAL 9003) con tecnica powder coating e polveri con elevato grado di purezza.

**Riflettore (non incluso):** in PC placcato in alluminio antiabbagliamento, disponibile in differenti colori.

**Conforme alla norma:** EN60598-1, RGO nessun rischio fotobiologico ai fini della norma EN62471.

**LED COB:** mantenimento del flusso luminoso minimo al 80%: L80B20>50.000h.

**Driver:** incluso.

**Prodotto conforme alle direttive:**

*Gloria LED, downlight with anti-glare panel for flush mounting installations, with recessed adjustable optics  $\pm 30^\circ$  vertical axis and  $255^\circ$  on the front axis, ideal for commercial and residential rooms and in any room where spot and accent lighting without glare is required. Anti-glare panel available in various colours.*

*Product body made of die-cast aluminium painted via powder coating technique and powders with a high degree of purity.*

*The special optics create a rectangular light distribution.*

*The range consists of products with a fixing system using flat springs, or in the trimless version for plasterboard finishing.*

**Installation:** ceiling flush mounting.

**Body:** die-cast aluminium. White painted (RAL 9003) with powder coating technique and powders with a high degree of purity.

**Reflector (not included):** in anti-glare aluminium plated PC, available in various colours. **Compliant with standard:** EN60598-1, RGO no photobiological risk for the purposes mentioned in standard EN62471.

**COB LED:** maintenance of 80% minimum luminous flux: L80B20>50.000h.

**Driver:** included.

**Product compliant with directives:**

### LED Gloria QR

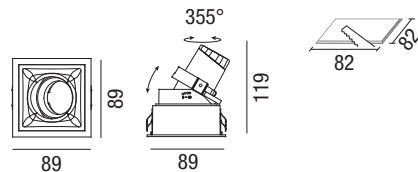

	W max	Lm Output		mA max	K	pcs	Kg	CELL
	8	800	wide	700	3000	001	0,314	47009NAPO
	8	800	wide	700	4000	001	0,314	47010NAPO
	8	800	wide	700	3000	001	0,314	47009DALNAPO
	8	800	wide	700	4000	001	0,314	47010DALNAPO
	13	1400	medium	350	3000	001	0,314	47007
	13	1400	medium	350	4000	001	0,314	47008
	13	1400	wide	350	3000	001	0,314	47009
	13	1400	wide	350	4000	001	0,314	47010
	13	1400	wide	350	3000	001	0,314	47009DALI
	13	1400	wide	350	4000	001	0,314	47010DALI

2700 K A richiesta / on demand



Riflettore da ordinare a parte  
Reflector to be ordered separately

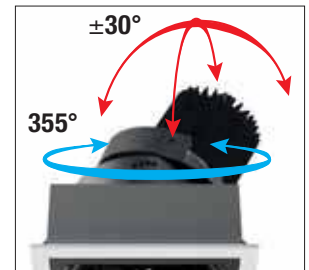

### Tabella di scelta potenza driver LED (incluso) - LED Power supply table choice (included)



Fornito di dip switch per la selezione della tensione in uscita. Il driver incluso nella confezione è normalmente settato alla massima corrente. Se necessario è possibile diminuire la potenza e di conseguenza i lumen output.

*Equipped with dip switch for selecting the voltage output. The driver included inside the package is usually set to max power. If necessary it is possible to decrease the power and consequently the lumen output.*

### Dati fotometrici - Photometric data

Medium

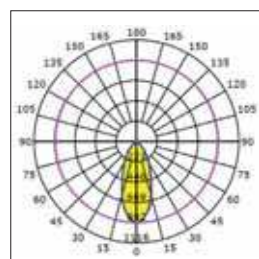

Wide

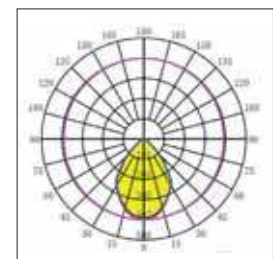

## Gesso ceramico

A RICHIESTA  
ON DEMAND



Relco consiglia:  
Relco recommends:

7W 3CCT -700lm/W  
3000-4000-6000K  
GU10 230V.

BASIC series



Cod. 555304.3CCT

Porta faretto in gesso a scomparsa di forma tonda o quadrata. Un elemento minimale, perfetto in ogni tipologia di ambiente da quello privato a quello pubblico. Istitato nel cartongesso risulta a scomparsa totale, semplice, lineare, moderno ed esteticamente essenziale, tanto da adattarsi alla perfezione a tutti i tipi di progetto. Perfetto per conciliare funzione ed estetica, illumina gli ambienti con eleganza, mettendo in risalto i dettagli. Semplice da installare su parete in cartongesso o laterizio, inserirlo, fare gli opportuni collegamenti e stuccare. Di colore bianco è possibile verniciarlo in tinta con gli interni o in base alle necessità e ai gusti personali.

**Installazione:** incasso a soffitto o a parete come segnapasso.

**Corpo:** ingesso ceramico fortificato.

**Conforme alla norma:** EN60598-1, RG0 nessun rischio fotobiologico ai fini della norma EN62471.

**LED:** mantenimento del flusso luminoso minimo al 80%: L80B20>50.000h.

**Driver:** incluso (nei codici HD 9043, HD9029).

Retractable plaster spotlight holder, round or square. A minimal element, perfect in any type of environment, whether private or public. Fitted in plasterboard it totally disappears, being simple, linear, modern and aesthetically essential, so much so that it perfectly fits into any type of design. It wonderfully blends function and aesthetics, lighting up environments with elegance, while highlighting details. Easy to install on plasterboard or brick walls, to insert it, to make the proper connections and to plaster. White colour, it can be painted like the interiors or based on necessity or personal preferences.

**Installation:** ceiling recessed.

**Body:** die-cast aluminium. Polyester powder coating.

**According to standard:** EN60598-1, RG0 exempt from photo-biological risks in compliance with standard EN62471.

**LED:** maintenance of minimum luminous flux to 80%: L80B20>50.000h.

**Driver:** <img alt="lightbulb icon" data-bbox="555 706 575 719"/> included in Kit (into HD 9043, HD9029).

### Informazioni tecniche di montaggio - Technical assembly information



Avvitare la staffa regolabile per cartongesso spessore da 9~15 mm.

Screw the adjustable bracket for plasterboard, 9-15 mm thick.



Collegare il portalamпада alla rete e alloggiare la lampada nella sede.

Connect the lamp holder to the mains and fit the lamp in its housing.



Assicurare la lampada alla staffa tramite due viti.

Secure the lamp to the bracket with the two screws.



Rasare a filo con gesso per pareti.

Smooth with wall plaster.



Collegare la lampadina al portalamпада.

Connect the lightbulb to the lamp holder.

# Gesso ceramico da incasso a rasare

## Recessed ceramic plaster to be smoothed

220-240V 50/60Hz

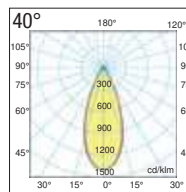
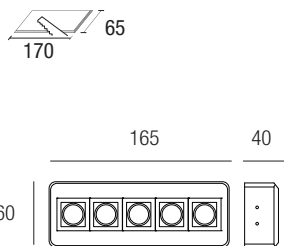

CRI 90

colour	W max		Lm Output		K	pcs	Kg	CELL
B	5	5 Led SMD	500	40	3000	001	0,314	HD9043

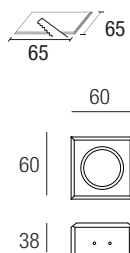
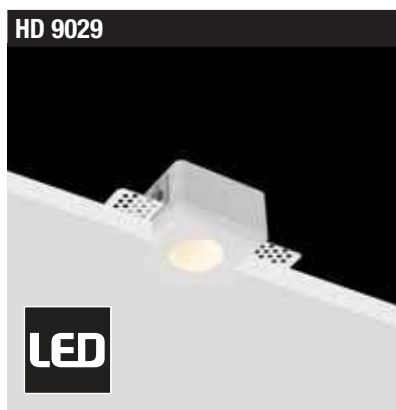

Vetro di protezione temperato  
Tempered safety glass

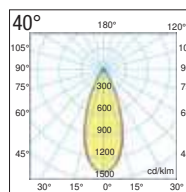

CRI 90

colour	W max		Lm Output		K	pcs	Kg	CELL
B	1,5	5 Led SMD	150	40	3000	001	0,314	HD9029

220-240V 50/60Hz **IK07** **IP20**

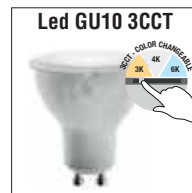
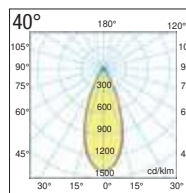
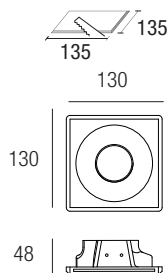

colour	W max		Lm Output		K	pcs	Kg	S
B	60	GU10	-	-	-	001	0,314	HD9003

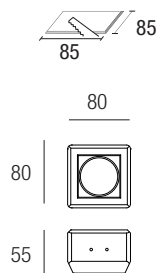

Vetro di protezione temperato  
Tempered safety glass

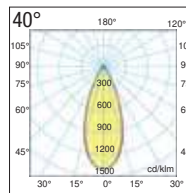

colour	W max		Lm Output		K	pcs	Kg	S
B	60	GU10	-	-	-	001	0,314	HD9028/T

Recessed

# Gesso ceramico da incasso a rasare

## Recessed ceramic plaster to be smoothed

220-240V 50/60Hz



IK07

IP20



HD 9028

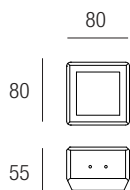

Vetro di protezione temperato  
Tempered safety glass

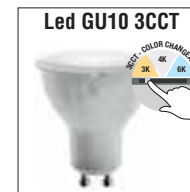
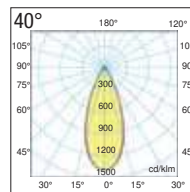

colour	W max		Lm Output		K	pcs	Kg	S
B	60	GU10	-	-	-	001	0,314	HD9028



HD 9001G

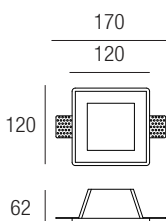

Vetro di protezione temperato  
Tempered safety glass

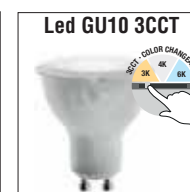
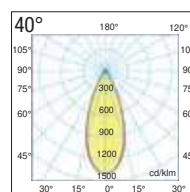

colour	W max		Lm Output		K	pcs	Kg	S
B	60	GU10	-	-	-	001	0,314	HD9001G



HD 8013

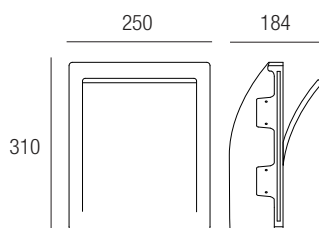

colour	W max		Lm Output		K	pcs	Kg	S
B	60	E14	-	-	-	001	0,314	HD8013



HD 8540

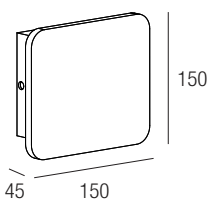

Vetro di protezione temperato  
Tempered safety glass



colour	W max		Lm Output		K	pcs	Kg	CELL
B	5,6	5 Led SMD	550	-	3000	001	0,400	HD8540

HD 8016

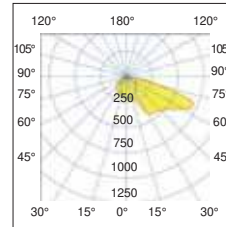
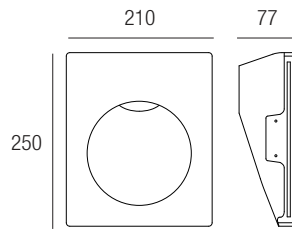
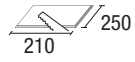

ASY  
Asimmetrica - Asymmetrical

colour	W max		Lm Output		K	pcs	Kg	S
B	60	GU10	-	-	-	001	0,314	HD8016



Recessed

## LED Imperceptible, the smallest

A RICHIESTA  
ON DEMAND

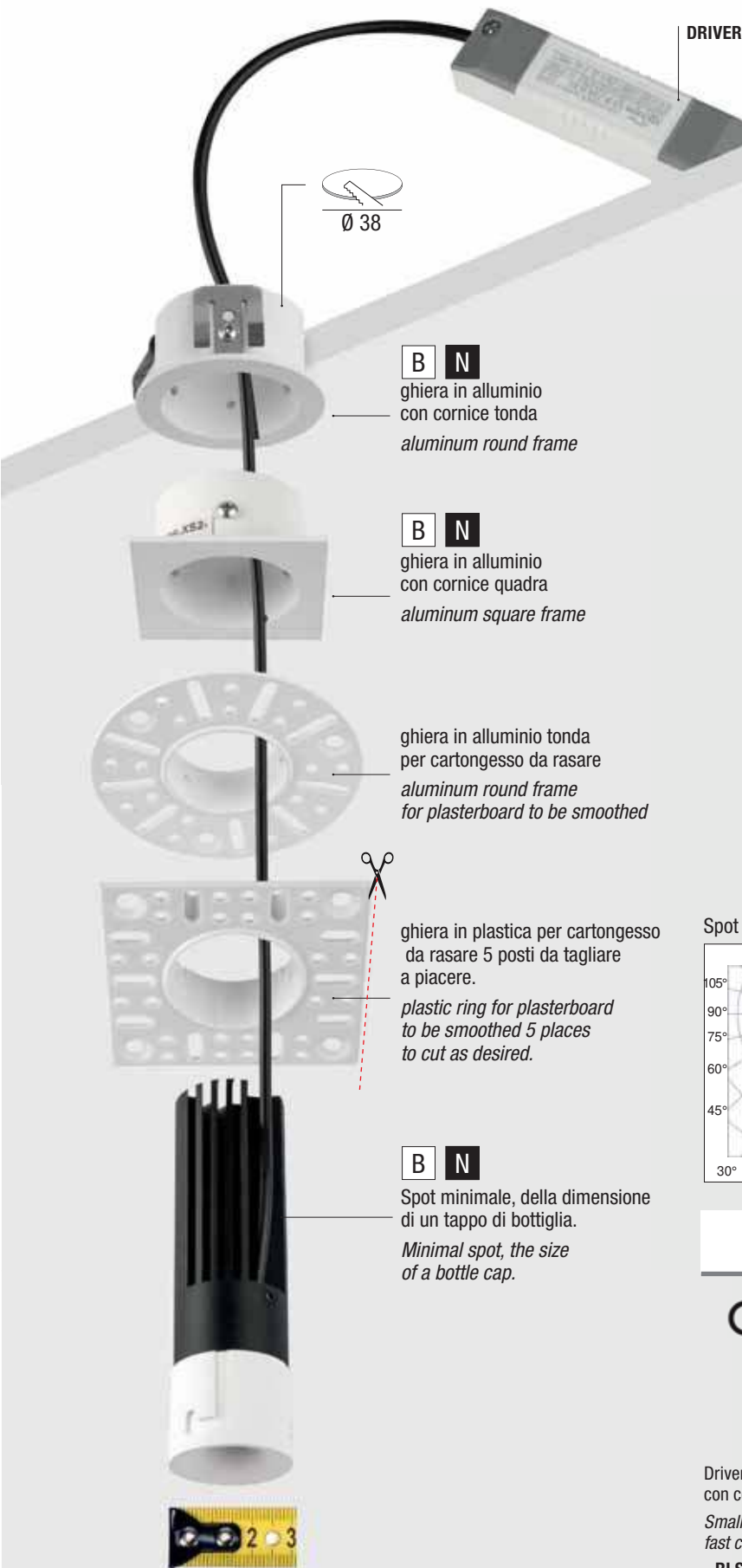

Ø 38

DRIVER

**B N**  
ghiera in alluminio  
con cornice tonda  
*aluminum round frame*

**B N**  
ghiera in alluminio  
con cornice quadra  
*aluminum square frame*

ghiera in alluminio tonda  
per cartongesso da rasare  
*aluminum round frame  
for plasterboard to be smoothed*

ghiera in plastica per cartongesso  
da rasare 5 posti da tagliare  
a piacere.  
*plastic ring for plasterboard  
to be smoothed 5 places  
to cut as desired.*

**B N**  
Spot minimale, della dimensione  
di un tappo di bottiglia.  
*Minimal spot, the size  
of a bottle cap.*

Spot 36°

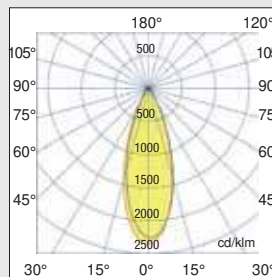

Spot 20°

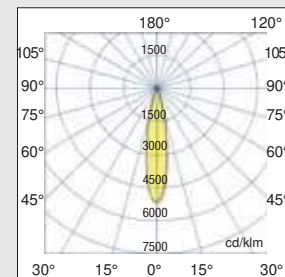

**Driver LED, accessorio non incluso**  
**LED driver, accessory not included**



Driver di ridotte dimensioni  
con connessione rapida.

Dimensioni (mm) - Dimensions (mm)

*Small size drivers with  
fast connection.*

- RLS-8-700SIE (max700mA) (ON-OFF)

- CC15W-100-700 (max700mA) (DALI2 PUSH)

SR-CC15UT (1x coprimorsetto - terminal cover  
acquistare 2 pcs - buy 2 pcs.)

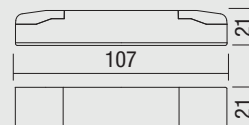

Recessed



LED Imperceptible, spots a LED con ottica arretrata. Foro ridottissimo dall'eccezionale luminosità. Installazione della sorgente luminosa tramite innesto a baionetta sui diffusori. Ideale per gli ambienti commerciali, residenziali e in qualsiasi ambiente dove si desidera mascherare completamente il corpo illuminante e ottenere un livello di comfort elevatissimo.

Apparecchi a base tonda o quadra, con sorgenti luminose singole o multiple.

**Installazione:** incasso a soffitto per superfici in cartongesso.

**Corpo:** alluminio pressofuso. Verniciatura di tipo poliestere eseguita a polvere bianco RAL 9003.

**Conforme alla norma:** EN60598-1, RG0 nessun rischio fotobiologico ai fini della norma EN62471.

**LED:** 2700K, 3000K o 4000K mantenimento del flusso luminoso minimo al 80%: L80B20>50.000h.

**Driver:** non incluso, di dimensioni ridotte adatto al passaggio nel foro di Ø38mm dedicato alle ghiera della versione singola o da rasare in cartongesso.

*LED Imperceptible, recessed luminaires with recessed optics.*

*Very small hole with exceptional brightness. Installation of the light source by bayonet coupling on the diffusers. Ideal for commercial and residential environments and in any environment where you want to completely mask the lighting fixture and obtain a very high level of comfort.*

*Round or square base fixtures, with single or multiple light sources.*

**Installation:** ceiling built-in on plasterboard surfaces.

**Body:** die-cast aluminum. Polyester type painting performed with white powder RAL 9003.

**Compliant with the standard:** EN60598-1, RG0 No photobiological risk for the purposes of the EN62471 standard.

**LED:** 2700K, 3000K o 4000K maintenance of the minimum luminous flux to 80%: L80B20>50.000h.

**Driver:** not included, small size suitable for the passage in the Ø38mm hole dedicated to the single version or to be shaped in plasterboard.

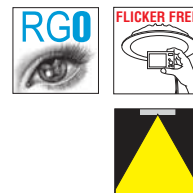
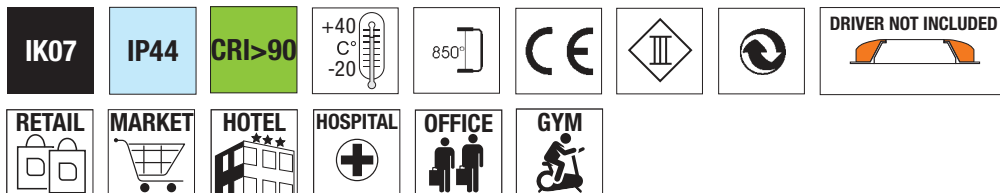

### LED Imperceptible 1001R



	W max	Lm Output	△	mA max	Vdc	K	pcs	Kg	S+L
B	10	560	20°	700	12	2700	1	0,05	39001/27KW/24
B	10	560	20°	700	12	3000	1	0,05	39001/3KW/24
B	10	620	20°	700	12	4000	1	0,05	39001/4KW/24
B	10	560	36°	700	12	2700	1	0,05	39001/27KW/36
B	10	560	36°	700	12	3000	1	0,05	39001/3KW/36
B	10	620	36°	700	12	4000	1	0,05	39001/4KW/36
N	10	560	20°	700	12	2700	1	0,05	39001/27KW/24B
N	10	560	20°	700	12	3000	1	0,05	39001/3KW/24B
N	10	620	20°	700	12	4000	1	0,05	39001/4KW/24B
N	10	560	36°	700	12	2700	1	0,05	39001/27KW/36B
N	10	560	36°	700	12	3000	1	0,05	39001/3KW/36B
N	10	620	36°	700	12	4000	1	0,05	39001/4KW/36B

Versione DALI aggiungere "D" dopo il codice / DALI version add "D" after the code.

### LED Imperceptible 1002R



	W max	Lm Output	△	mA max	Vdc	K	pcs	Kg	S+L
B	10	275	20°	700	12	2700	1	0,05	39002/27KW/24
B	10	275	20°	700	12	3000	1	0,05	39002/3KW/24
B	10	290	20°	700	12	4000	1	0,05	39002/4KW/24
B	10	275	36°	700	12	2700	1	0,05	39002/27KW/36
B	10	275	36°	700	12	3000	1	0,05	39002/3KW/36
B	10	290	36°	700	12	4000	1	0,05	39002/4KW/36
N	10	275	20°	700	12	2700	1	0,05	39002/27KW/24B
N	10	275	20°	700	12	3000	1	0,05	39002/3KW/24B
N	10	290	20°	700	12	4000	1	0,05	39002/4KW/24B
N	10	275	36°	700	12	2700	1	0,05	39002/27KW/36B
N	10	275	36°	700	12	3000	1	0,05	39002/3KW/36B
N	10	290	36°	700	12	4000	1	0,05	39002/4KW/36B

Versione DALI aggiungere "D" dopo il codice / DALI version add "D" after the code.

### LED Imperceptible 1003R



	W max	Lm Output	△	mA max	Vdc	K	pcs	Kg	S+L
N	10	265	20°	700	12	2700	1	0,05	39003/27KW/24B
N	10	265	20°	700	12	3000	1	0,05	39003/3KW/24B
N	10	285	20°	700	12	4000	1	0,05	39003/4KW/24B
N	10	265	36°	700	12	2700	1	0,05	39003/27KW/36B
N	10	265	36°	700	12	3000	1	0,05	39003/3KW/36B
N	10	285	36°	700	12	4000	1	0,05	39003/4KW/36B

Versione DALI aggiungere "D" dopo il codice / DALI version add "D" after the code.



Recessed

# incasso con cornice in alluminio - *recessed with aluminum frame*

LED Imperceptible 1001R\*



LED Imperceptible 1002R



LED Imperceptible 1003R



ghiera in alluminio con cornice tonda  
*aluminum round frame*



ghiera in alluminio con cornice quadra  
*aluminum square frame*



ghiera in alluminio tonda da rasare  
*aluminum round frame to be smoothed*





# cornice in plastica per cartongesso a rasare - *plastic frame recessed plasterboard*

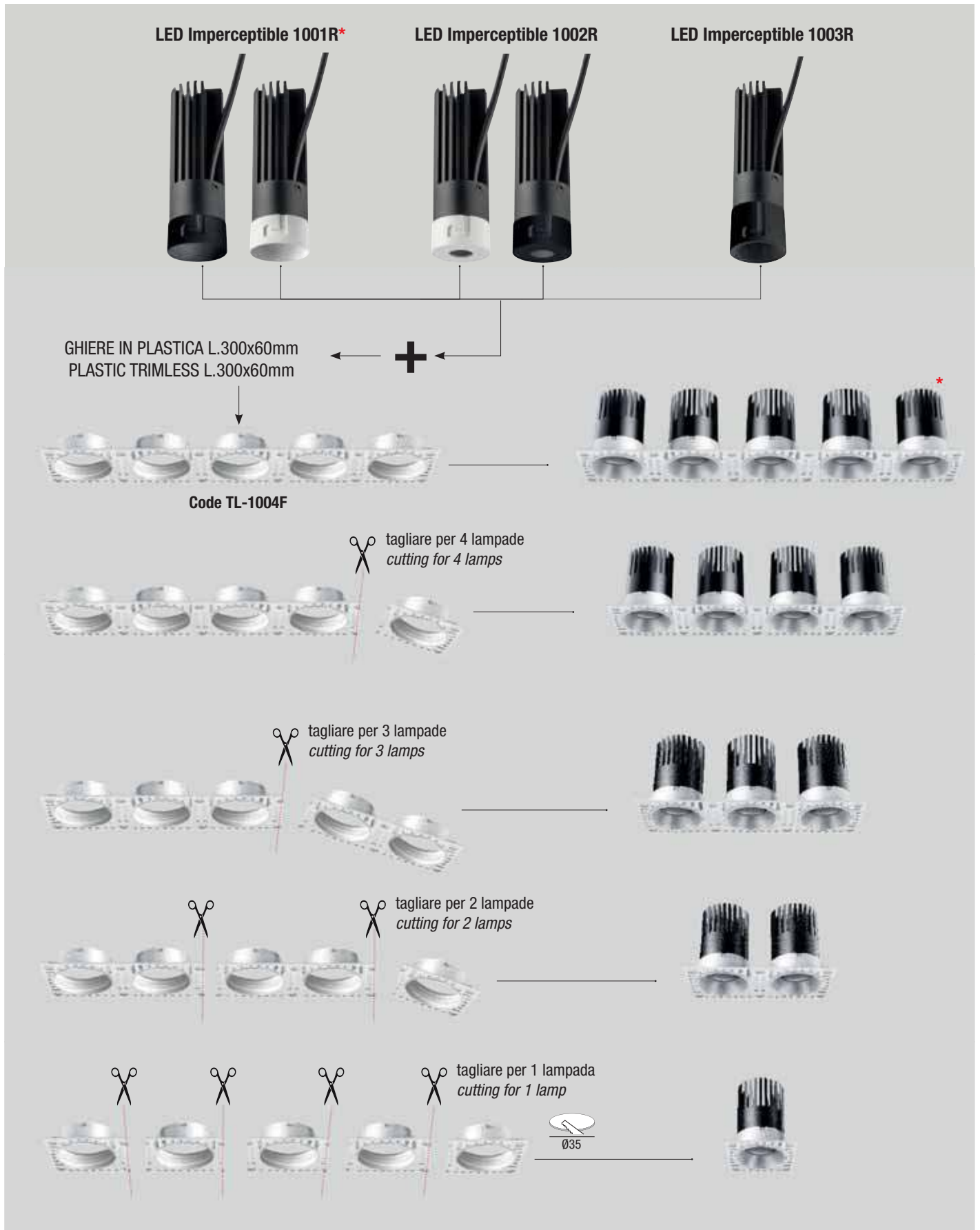

\* Esempio di installazione **LED Imperceptible 1001R** su ghiera per cartongesso, è possibile utilizzare uno qualsiasi dei 4 modelli. La ghiera da 5 moduli (codice TL-1004F) può essere tagliata per ottenere moduli da 4, 3, 2 o 1 modulo singolo.  
*Example of **LED Imperceptible 1001R** installation on plasterboard frames, any of the 4 models can be used.  
 The 5-module ring (code TL-1400F) can be cut to obtain modules of 4, 3, 2 or 1 single module.*



## LED Aqua IP65

A RICHIESTA  
ON DEMAND



DRIVER NON INCLUSO  
DRIVER NOT INCLUDED

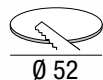

**B N**

ghiera in alluminio  
con cornice tonda  
*aluminum round frame*

ghiera in alluminio tonda  
per cartongesso da rasare  
*aluminum round frame  
for plasterboard to be smoothed*



ghiera in plastica per cartongesso  
da rasare 5 posti da tagliare  
a piacere.  
*plastic ring for plasterboard  
to be smoothed 5 places  
to cut as desired.*

**B N**

Spot IP65.  
*IP65 Spot lights.*

Ø 44,7

**Driver LED, accessorio non incluso**  
**LED driver, accessory not included**



Dimensioni (mm) - Dimensions (mm)

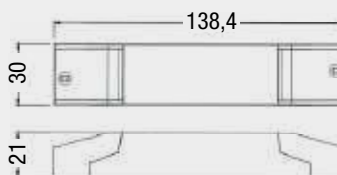

**RN7136DA** (DALI2 PUSH)  
Coprimerseiti inclusi  
*Terminal covers included*

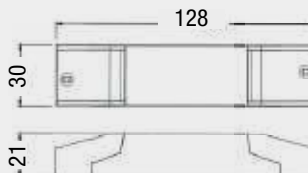

**RN7136** (ON-OFF)  
Coprimerseiti non inclusi  
*Terminal covers not included*  
**7136TB**  
Coprimerseito - Terminal cover  
(ordinare 2 pezzi/order 2 pcs)

**Tabella di scelta potenza driver LED (versione 3000K)**  
**LED Power supply table choice (3000K version)**

<b>I<sub>out</sub></b>	<b>mA</b>	150	200	250
<b>V<sub>out</sub></b>	<b>Vdc</b>	36	36	36
<b>Power</b>	<b>W</b>	<b>6</b>	<b>8</b>	<b>10</b>
<b>Lm</b>	<b>Lm</b>	507	676	846

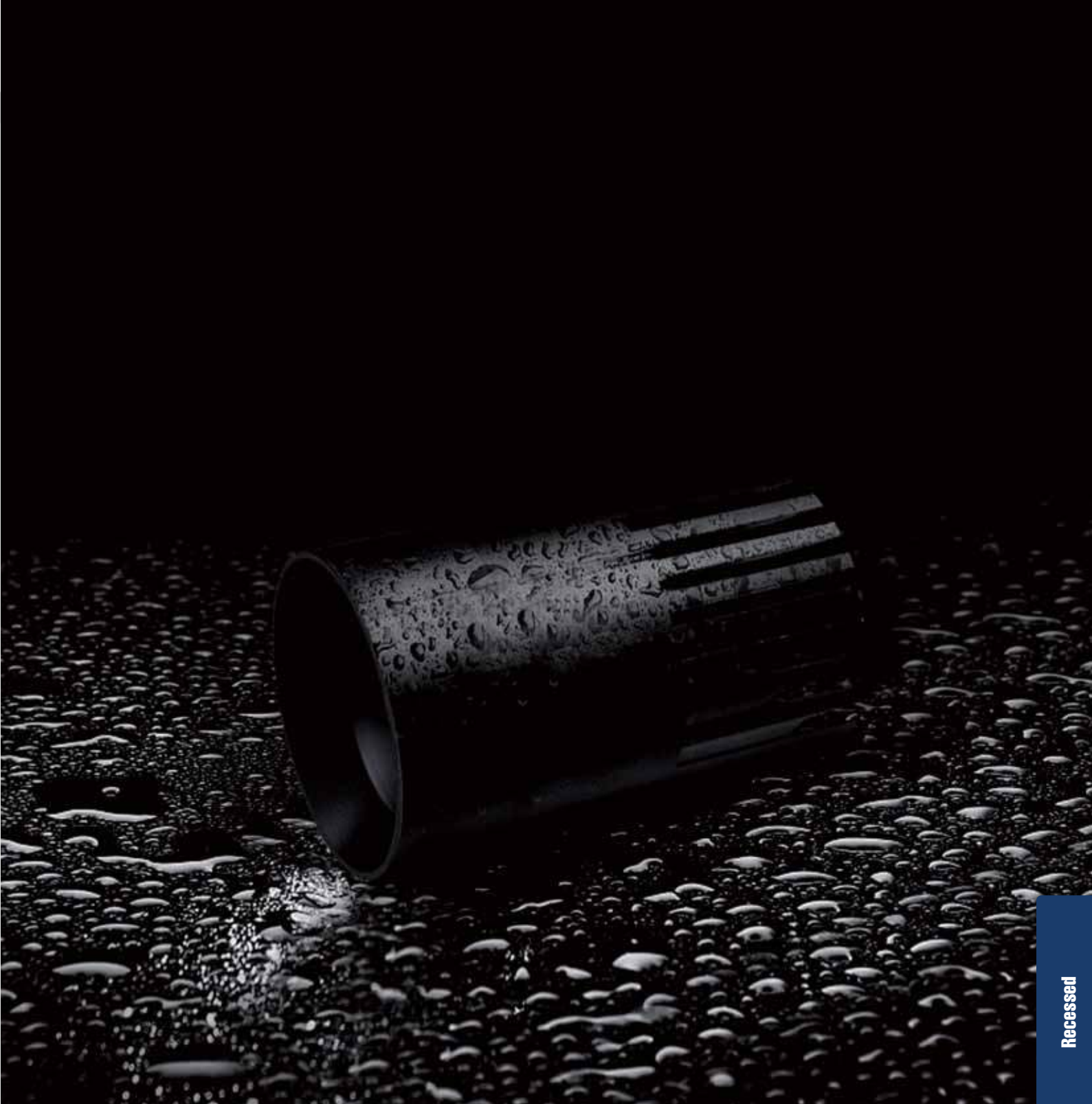

LED Aqua, spots a LED IP65 con ottica arretrata dall'eccezionale luminosità. Installazione della sorgente luminosa tramite innesto a bionetta sui diffusori. Ideale per gli ambienti umidi, grazie all'elevato grado IP è possibile installarlo in palestre, piscine, saune, bagni e in qualsiasi ambiente dove si desidera mascherare completamente il corpo illuminante e ottenere un livello di comfort elevatissimo.

Apparecchi a base tonda o quadra, con sorgenti luminose singole o multiple.

**Installazione:** incasso a soffitto per superfici in cartongesso.

**Corpo:** alluminio pressofuso. Verniciatura di tipo poliestere eseguita a polvere bianco RAL 9003.

**Conforme alla norma:** EN60598-1, RG0 nessun rischio fotobiologico ai fini della norma EN62471.

**LED:** 2700K, 3000K o 4000K mantenimento del flusso luminoso minimo al 80%: L80B20>50.000h.

**Driver:** non incluso, di dimensioni ridotte adatto al passaggio nel foro di Ø52mm dedicato alle ghiera della versione singola o da rasare in cartongesso.

*LED Aqua, IP65 LED spots with recessed optics with exceptional brightness. Installation of the light source via bayonet connection on the diffusers. Ideal for humid environments, thanks to the high IP rating it is possible to install it in gyms, swimming pools, saunas, bathrooms and in any environment where you want to completely mask the lighting body and obtain a very high level of comfort.*

*Round or square base fixtures, with single or multiple light sources.*

**Installation:** ceiling built-in on plasterboard surfaces.

**Body:** die-cast aluminum. Polyester type painting performed with white powder RAL 9003.

**Compliant with the standard:** EN60598-1, RG0 No photobiological risk for the purposes of the EN62471 standard.

**LED:** 2700K, 3000K o 4000K maintenance of the minimum luminous flux to 80%: L80B20>50.000h.

**Driver:** not included, small size suitable for the passage in the Ø52mm hole dedicated to the single version or to be shaped in plasterboard.

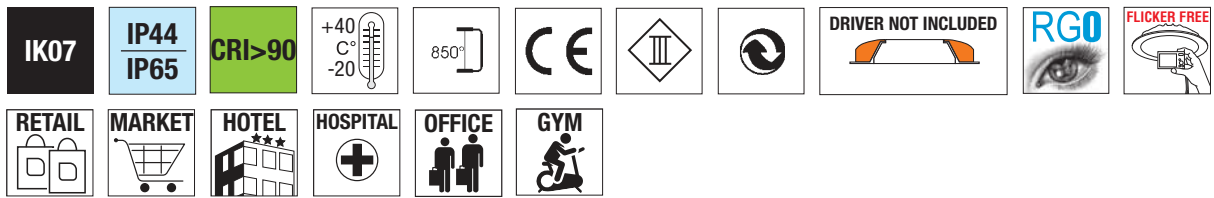

**LED Aqua 1201R**

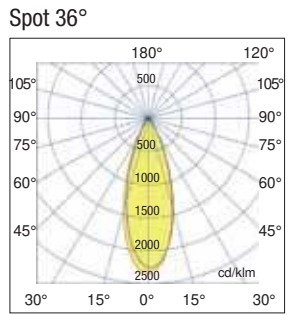
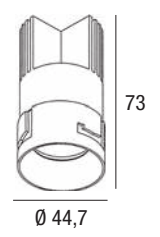

	W max	Lm Output	Beam	mA max	Vdc	K	pcs	Kg	S+L
B	10	800	36°	250	36	2700	1	0,10	1201RW27IP65
B	10	846	36°	250	36	3000	1	0,10	1201RW3IP65
B	10	900	36°	250	36	4000	1	0,10	1201RW4IP65
N	10	800	36°	250	36	2700	1	0,10	1201RBL27IP65
N	10	846	36°	250	36	3000	1	0,10	1201RBL3IP65
N	10	900	36°	250	36	4000	1	0,10	1201RBL4IP65

**incasso con cornice in alluminio - recessed with aluminum frame**

+

ghiera in alluminio con cornice tonda  
*aluminum round frame*

CUT Ø52

Cod. 1201FW  
misura-size Ø57,6mm

ghiera in alluminio con cornice tonda  
*aluminum round frame*

CUT Ø52

Cod. 1201FBL  
misura-size Ø57,6mm

ghiera in alluminio tonda da rasare  
*aluminum round frame to be smoothed*

CUT Ø50

Cod. 1203F  
misura-size Ø47mm

Recessed



# cornice in plastica per cartongesso a rasare - *plastic frame recessed plasterboard*

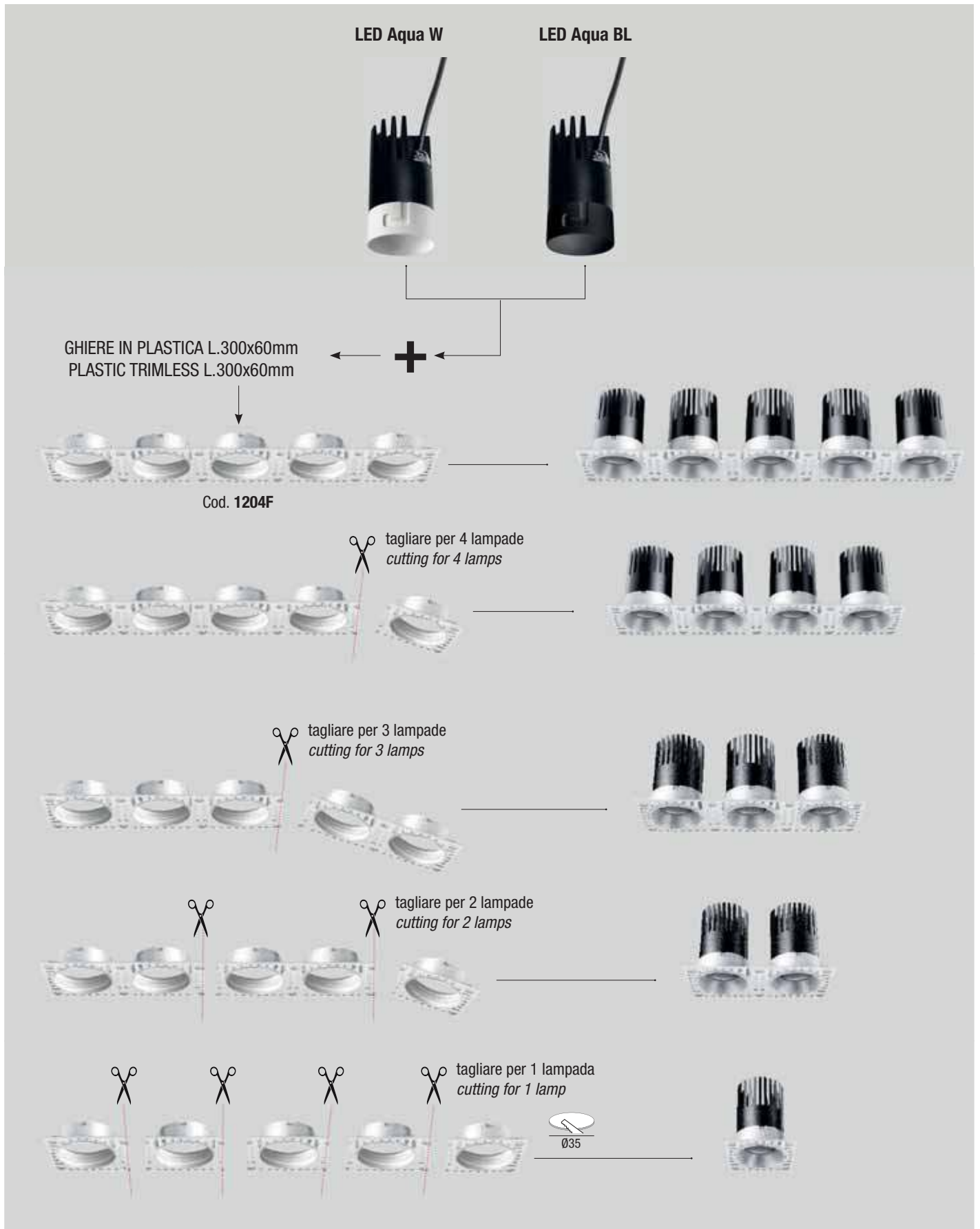

Esempio di installazione su ghiera per cartongesso.

La ghiera da 5 moduli (codice 1204F) può essere tagliata per ottenere moduli da 4, 3, 2 o 1 modulo singolo.

*Example of installation on plasterboard frames.*

*The 5-module ring (code 1204F) can be cut to obtain modules of 4, 3, 2 or 1 single module.*

## LED Life 150-LED Life IP54

A RICHIESTA  
ON DEMAND



min Ø 185  
max Ø 225

Ø 150

min Ø 185  
max Ø 225

Ø 150

Ø 150

min Ø 185  
max Ø 225

**3 CCT SWITCHABLE**

WW	NW	CW
▲ 3000K	▲ 4000K	▲ 6000K

Con cambio tonalità mediante selettore integrato posizionato sul corpo lampada è possibile scegliere la temperatura di colore preferita.

*With the integrated selector switch on the lamp body, you can choose your preferred color temperature.*

Apparecchi ad incasso progettati per illuminare aree comuni, corridoi, laboratori, sale riunioni, uffici, cucine e bagni e qualsiasi ambiente dove è necessaria un'illuminazione con ridotti livelli di abbagliamento. Ideale per luoghi umidi.

**Installazione:** ad incasso per controsoffitti in cartongesso (completo di staffe di fissaggio).

**Corpo e telaio:** in alluminio pressofuso UNI 5076 verniciato con polvere termoisolante, poliestere.

**Staffe di fissaggio:** in acciaio nichelato.

**Verniciatura:** di tipo poliestere eseguita a polvere. Colore bianco RAL 9003

**Ottica:** parabola in alluminio diffondente, semi diffondente, .

**Schermo:** vetro.

**Temperatura di colore: LED Life:** 3000K - 4000K; altre temperature di colore a richiesta. **LED Life 150:** disponibile 3CCT (3000K-4000K-6000K).

**Driver multipotenza:** Fattore di potenza  $\geq 0,95$ .

**Conforme alla norma:** EN60598-1, RG0 nessun rischio fotobiologico ai fini della norma EN62471.

**Led COB:** mantenimento del flusso luminoso minimo al 80%: L90B10>100.000h.

**A richiesta:** versione 110V. **Prodotto conforme alle direttive:**

*Recessed downlights designed to light up common areas, corridors, laboratories, meeting rooms, offices kitchens, bathrooms and any other place that requires diffused lighting with no glare effect. The series consists of recessed fittings with increased protection degree ideal for humid places.*

**Installation:** recessed use in plasterboard false ceilings (complete with fixing brackets)

**Body and frame:** made by UNI 5076 die-cast aluminum, coated with polyester thermoset powder.

**Fixing brackets:** made by galvanized steel

**Coating:** coated with powdered polyester. RAL 9003 white color.

**Optic:** semi-diffused, diffused aluminum parabola.

**Shield:** glass.

**Color temperature: LED Life:** 3000K - 4000K; other color temperatures available on demand. **LED Life 150:** available 3CCT (3000K-4000K-6000K).

**Driver multipower:** Power factor  $\geq 0,95$ .

**According to standard:** EN60598-1, RG0 exempt from photo-biological risks in compliance with standard EN62471.

**Led COB:** maintenance of minimum luminous flux to 80%: L90B10>100.000h.

**On demand:** 110V version. **Product compliant with directives:**



### LED Life 150 - Opal

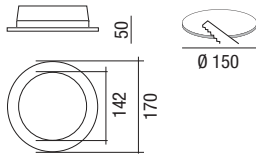

**3CCT**  
SWITCHABLE

max  
500mA

DRIVER NOT INCLUDED  
S+L

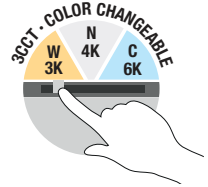

### LED LIFE R PLUS OPAL 150 - 3CCT

colour	W max	mA max	△	lm output	K			pcs	Kg	S+L
B	21	500	100°	max 2300	3000	4000	6000	001	0.33	2436-

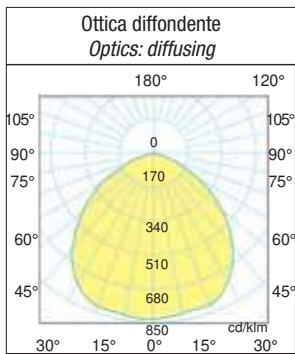

### LED Life 150 - Cromo

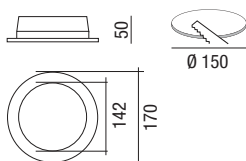

**3CCT**  
SWITCHABLE

max  
500mA

DRIVER NOT INCLUDED  
S+L

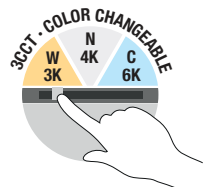

### LED LIFE R PLUS CROMO 150 - 3CCT

colour	W max	mA max	△	lm output	K			pcs	Kg	S+L
B	21	500	100°	max 2300	3000	4000	6000	001	0.33	2436/CR-

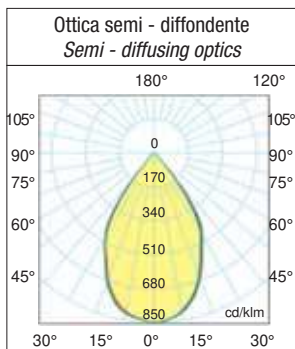

Recessed

## LED Life 150 - Specchio

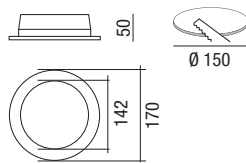

**3CCT**  
SWITCHABLE

max  
**500mA**

DRIVER NOT INCLUDED  
S+L

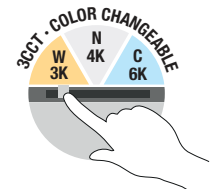

## LED LIFE R PLUS SPECCHIO 150 - 3CCT

colour	W max	mA max	Im output	K	pcs	Kg	S+L			
B	21	500	100°	max 2300	3000	4000	6000	001	0.33	2436/SP-

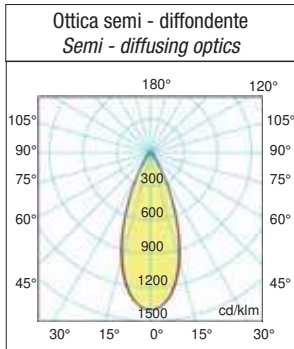

## Accessori non inclusi - Not included accessories



**Anello riduttore a battuta.**  
*Reducer ring (for application against a surface)*  
**Cod. 24398-150**  
Anello riduttore bianco RAL 9003 per LED Life 150. È adatto per fori da Ø 150mm a Ø 180mm max.  
*White RAL 9003 reduction ring for LED Life 150. It is suitable for hole diameter from Ø 150mm to Ø 180mm max.*



**Kit emergenza**  
*Emergency kit*  
**Cod. 65151LED80CP3**  
Kit emergenza 3W - 3h/12% 180÷250 Vac  
*180÷250 Vac - 3h/12% - 3W emergency kit*  
**Cod. RP0714CP3 - AUTOTEST**  
Kit emergenza 3W - 3h/12% 180÷250 Vac  
*180÷250 Vac - 3h/12% - 3W emergency kit*

CE RoHS compliance F M M equi SELV EMC 300MHz IP20 PFC VDT LED driver multipower



**RN8166 - DALI 2 PUSH**  
**Taratura max 500mA - Max setting 500mA**  
Fornito di dip switch per la selezione della corrente in uscita. Il driver non è incluso nella confezione ed è normalmente settato al minimo. Se necessario è possibile aumentare la potenza e di conseguenza i lumen output senza superare i 500mA.  
*Equipped with dip switch for selecting the current output. The driver is not included inside the package and is normally set to minimum. If necessary it is possible to increase the power and consequently the lumen output without exceeding 500mA.*

**Cod. 7136TB\***  
Coprimerzetti NON INCLUSI (da ordinare a parte per RN9152-N)  
*Terminal cover NOT INCLUDED (ordinarily a part to RN9152-N)*

## Tabella di scelta potenza driver LED - LED Power supply table choice



Fornito di dip switch per la selezione della tensione in uscita. Il driver è normalmente settato a 7W (150mA) vedi tabella. Se necessario è possibile aumentare la potenza e di conseguenza i lumen output fino ad un massimo di 21W (500mA).  
*Equipped with dip switch for selecting the voltage output The driver is usually set to 7W (150 mA) see table. If necessary, it is possible to increase the power and consequently the lumen output up to a maximum of 21W (500mA).*

Taratura Dip-switch	Potenza Power	Lm Output
mA	Watt	Lm
150	7	770
200	9	990
250	11	1210
300	13	1430
350	15	1650
400	17	1870
450	19	2090
500	21	2300



### LED Life - OPAL

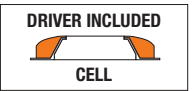
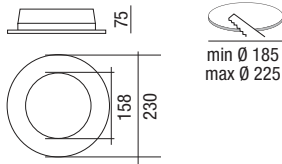

colour	W max	△	lm output	K	pcs	Kg	CELL
B	30	100°	max 3200	3000	001	0.57	24363/SP/PLUS
B	30	100°	max 3200	4000	001	0.57	24365/SP/PLUS
<b>DALI 2</b> PUSH B	30	100°	max 3200	3000	001	0.57	24363/30/SPDA
<b>DALI 2</b> PUSH B	30	100°	max 3200	4000	001	0.57	24365/30/SPDA

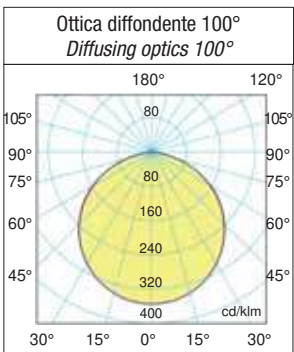

### LED Life - Cromo

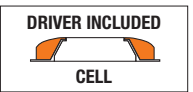
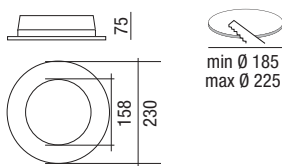

colour	W max	△	lm output	K	pcs	Kg	CELL
B	30	100°	max 3450	3000	001	0.57	24363/30/DL
B	30	100°	max 3450	4000	001	0.57	24365/30/DL
<b>DALI 2</b> PUSH B	30	100°	max 3450	4000	001	0.57	24365/30/DLDA

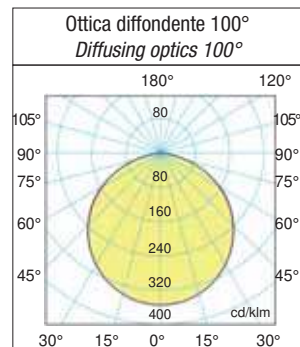

Recessed

## LED Life - Darklight

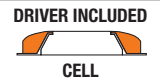
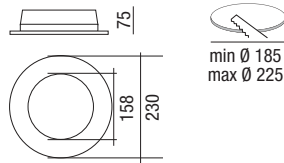

A richiesta: versione 3000K (consegna 90gg.)  
On demand: 3000K versions (delivery 90 days)

	W max	Beam angle	lm output	K	pcs	Kg	CELL
[B]	30	40°	max 3450	4000	001	0.57	24365/40/DL/N
[B]	30	60°	max 3450	4000	001	0.57	24365/60/DL/N
<b>DALI 2</b> PUSH [B]	30	40°	max 3450	4000	001	0.57	2436540DLNDA

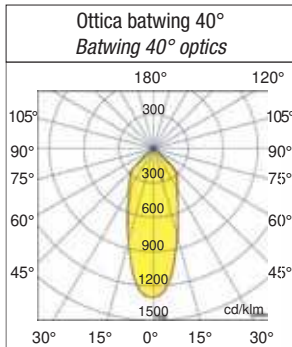

### Accessori non inclusi - Not included accessories

Anello riduttore a battuta  
Reducer ring (for application against a surface)

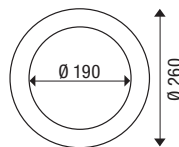

**Cod. 24398**  
Anello riduttore bianco RAL 9003 per LED Life R IP54. È adatto per fori da Ø 210mm a Ø 250mm max.  
White RAL 9003 reduction ring for LED Life R IP54. It is suitable for hole diameter from Ø 210mm to Ø 250mm max



**Kit emergenza**  
Emergency kit

**Cod. 65151LED80CP3**  
Kit emergenza 3W - 3h/12% 180÷250 Vac  
180÷250 Vac - 3h/12% - 3W emergency kit

**Cod. RP0714CP3 - AUTOTEST**  
Kit emergenza 3W - 3h/12% 180÷250 Vac  
180÷250 Vac - 3h/12% - 3W emergency kit

### Tabella di scelta potenza driver LED (incluso) - LED Power supply table choice (included)



Fornito di dip switch per la selezione della tensione in uscita. Il driver incluso nella confezione è normalmente settato a 26W (vedi tabella). Se necessario è possibile aumentare max 30W la potenza e di conseguenza i lumen output.

Equipped with dip switch for selecting the voltage output. The driver included inside the package is usually set to 26W (see table). If necessary it is possible to increase max 30W the power and consequently the lumen output.

Taratura Dip-switch	Potenza Power	Lm Output
mA	Watt	Lm
500	22	2530
600	26	2990
700	30	3450

Taratura standard di fabbrica  
Driver Standard factory setting

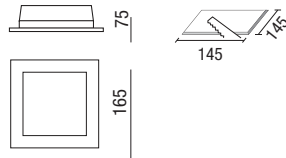
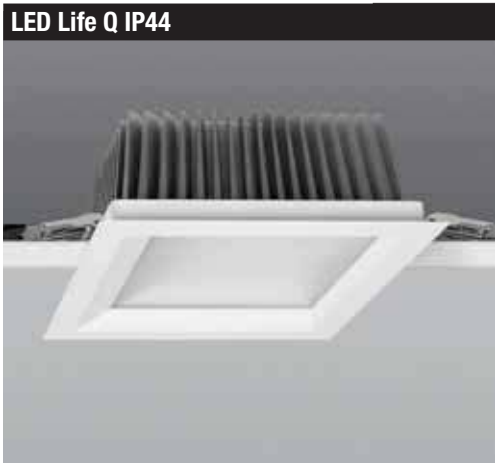

colour	W max			lm output	K	pcs	Kg	CELL
B	30	Led SMD	100°	3000	3000	001	0.57	24393
PUSH B	30	Led SMD	100°	3000	3000	001	0.57	24393/DALI
B	30	Led SMD	100°	3000	4000	001	0.57	24393/4K
PUSH B	30	Led SMD	100°	3000	4000	001	0.57	24393/4K/DALI



**Accessori non inclusi - Not included accessories**

Kit emergenza  
Emergency kit



**Cod. 65151LED80CP3**  
Kit emergenza 3W - 3h/12% 180÷250 Vac  
180÷250 Vac - 3h/12% - 3W emergency kit

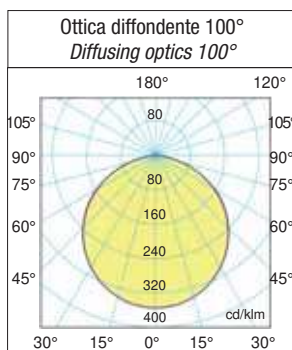

Fornito di dip switch per la selezione della tensione in uscita. Il driver incluso nella confezione è normalmente settato a 26W (vedi tabella). Se necessario è possibile diminuire o aumentare fino a max.30W la potenza e di conseguenza i lumen output.  
*Equipped with dip switch for selecting the voltage output. The driver included inside the package is usually set to 26W (see table). If necessary it is possible to decrease or increase to max 30W the power and consequently the lumen output.*

Taratura Dip-switch	Potenza Power	Lm Output
mA	Watt	Lm
500	22	2100
600	26	2300
700	30	2600

Taratura standard di fabbrica  
Driver Standard factory setting

## LED Marian



A RICHIESTA  
ON DEMAND



Downlights progettati per illuminare spazi commerciali (supermercati, grandi magazzini, retail, ecc.), uffici e qualsiasi ambiente dove è necessaria un'illuminazione generale e d'accento.

**Installazione:** ad incasso in controsoffitti di cartongesso (completo di staffe di fissaggio).

**Corpo:** in lamiera di acciaio, verniciata con polvere termoindurente poliestere RAL9010.

**Staffe di fissaggio:** in acciaio.

**Ottica:** semi concentrante 40°, orientabile +-15°.

**Temperatura di colore:** 3000K - 4000K, disponibile 3CCT.

**Driver:** multipotenza con selezione del dip switch per scegliere la tensione in uscita. Fattore di potenza ≥0,95.

**Conforme alla norma:** EN60598-1, RG0 nessun rischio fotobiologico ai fini della norma EN62471.

**Led:** SAMSUNG mantenimento del flusso luminoso minimo al 80%: L80B20>50.000h.

*Downlights designed for lighting in shopping malls (supermarkets, department stores, retail stores, etc.), offices and any facility requiring general and accent lighting.*

**Installation:** flush mounting in plasterboard false ceilings (fixing brackets included).

**Body:** in sheet steel, painted with thermo-hardening polyester RAL9010.

**Fastening brackets:** in steel.

**Optics:** semi-clumping 40°, +-15° adjustable.

**Colour temperature:** 3000K - 4000K, available 3CCT.

**Driver:** Multipower with dip switch selection to select the output voltage.

Power factor ≥0.95.

**Compliant with standard:** EN60598-1, RG0 no photobiological risk for the purposes mentioned in standard EN62471.

**LED:** SAMSUNG maintenance of 80% minimum luminous flux: L80B20>50.000h.



220-240V 50/60Hz **IK07** **IP20**

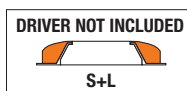
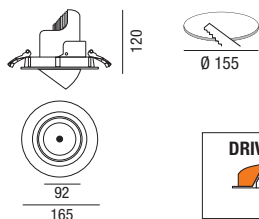

colour	W max			K	Lm	pcs	Kg	CELL
B	30	1 Led COB	40°	4000	max 3000	001	1.70	24318

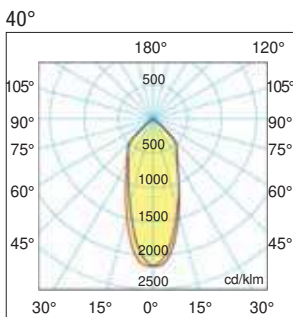

### LED Marian 3CCT

colour	W max	mA max		K	lm output	pcs	Kg	S+L
B	30	700	40°	3000 4000 6000	max 3000	001	1.70	24317-3CCT

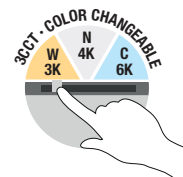

Accessorio non incluso (S+L) - Not included accessory (S+L)



LED driver multipower

**RN8167 - ON-OFF ON-OFF Taratura max 700mA**  
**RN8166 - DALI2 PUSH Taratura max 700mA**

Forniti di dip switch per la selezione della corrente in uscita. Il driver non è incluso nella confezione ed è normalmente settato al minimo. Se necessario è possibile aumentare la potenza e di conseguenza i lumen output senza superare i 700mA.

**Equipped with dip switch for selecting the current output.** The driver is not included inside the package and is normally set to minimum. If necessary it is possible to increase the power and consequently the lumen output without exceeding 700mA.



**3CCT SWITCHABLE**

WW 3000K    NW 4000K    CW 6000K

Con cambio tonalità mediante selettore integrato posizionato sul corpo lampada è possibile scegliere la temperatura di colore preferita.

*With the integrated selector switch on the lamp body, you can choose your preferred color temperature.*

## Equal Family R-C-W

A RICHIESTA  
ON DEMAND

WIRELESS

0-10V

DALI 2



Recessed/ceiling

Famiglia di apparecchi ad incasso, plafone, parete e sospensione ad elevato comfort visivo. Ideale per spazi dove è necessario un basso livello di abbagliamento. Il bassissimo consumo energetico e le contenute temperature garantiscono una lunga durata al prodotto.

L'utilizzo della tecnologia LED garantisce una resa luminosa elevata in relazione al consumo di energia, annullando i costi di manutenzione.

**Installazione:** ad incasso su cartongesso, plafone, parete e a sospensione.

**Corpo e telaio:** corpo realizzato in alluminio anodizzato pressofuso verniciato nelle finiture bianco RAL9010 o in nero RAL9005, Equal Road con cornice grigia.

**Staffe di fissaggio:** in acciaio

**Verniciatura:** di tipo poliestere eseguita a polvere.

**Ottica:** in materiale termoplastico, ad alta definizione integrata nello schermo antiabbagliamento nero o bianco che definisce un'emissione con luminanza controllata. Ottiche: wide flood.

Il particolare sistema ottico permette una distribuzione luminosa definita, evitando l'effetto puntiforme.

**Temperatura di colore:** 3000K Equal Road, 3000K e 4000K serie Equal (6000K a richiesta).

**Driver multipotenza:** incluso. Fattore di potenza  $\geq 0,95$

**Conforme alla norma:** EN60598-1, RG0 nessun rischio fotobiologico ai fini della norma EN62471.

**Led:** Mantenimento del flusso luminoso minimo al 80%: L80B20>50.000h.

*Family of recessed, surface-mounted, wall and pendant luminaires with high visual comfort. Ideal for spaces where a low level of glare is required.*

*Very low energy consumption and low temperatures guarantee a long product life.*

*LED technology guarantees high light output in relation to energy consumption, eliminating completely maintenance costs.*

**Installation:** flush mounted with no tools required or ceiling-mounted with the accessory to be ordered separately.

**Body and frame:** body made of die-cast anodized aluminum painted in white RAL9010 or black RAL9005, Equal Road with gray frame.

**Fastening brackets:** in steel

**Painting:** powder polyester coating.

**Optics:** made of high-definition thermoplastic material integrated into the black or white anti-glare screen that defines controlled luminance emission. Wide flood optics.

The particular optical system allows for defined and circular light distribution, avoiding the punctiform effect.

**Colour temperature:** 3000K Equal Road, 3000K and 4000K Equal series (6000K on request).

**Multipower driver:** included. Power factor  $\geq 0,95$

**According to standard:** EN60598-1, RG0 exempt from photo-biological risks in compliance with standard EN62471.

**Led:** Maintenance of minimum luminous flux to 80%: L80B20>50.000h.

# panoramica prodotti - *products overview*

## Equal Road incasso/recessed



## Equal incasso/recessed

LED Equal 4 R

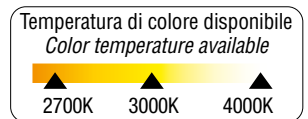

## Equal parete plafone/wall ceiling

LED Equal 4 CW double



LED Equal 4 C

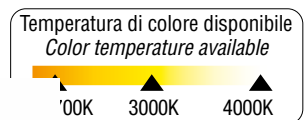

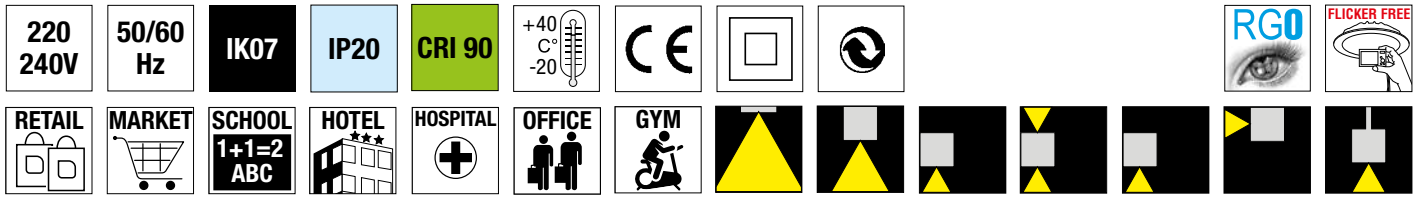

**LED Road Equal R 10**



220-240V 50/60Hz **IK07** **IP20**

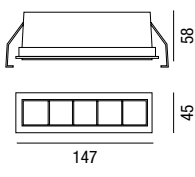

colour	W		lm output	K	pcs	Kg	CELL
<b>G N</b>	9	30°	800	3000	001	0,23	28200
<b>DALI 2 G N</b>	9	30°	800	3000	001	0,23	28200/DA

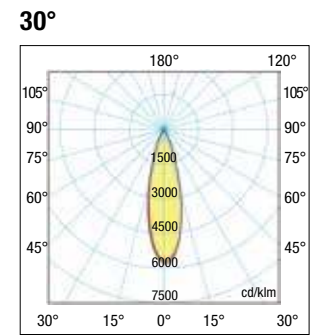

**Accessori non inclusi - Not included accessories**

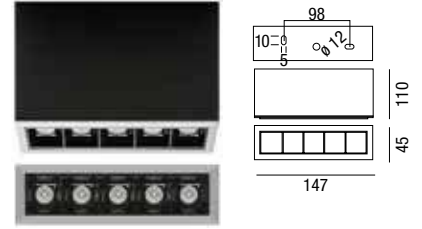

**LED Equal Road 10W**  
**LED Equal Road 20W**  
 Cassaforma esterna per montaggio a soffitto. Rimuovendo le molle di fissaggio sul corpo del faretto è possibile installarlo sulla cassaforma tramite due viti a brugola in dotazione. Aggiungere /C dopo il codice.  
*External formwork for ceiling mounting. By removing the fixing springs on the body of the spotlight it is possible to install it on the formwork using two supplied Allen screws. Add /C after the code.*

**LED Road Equal R 20**

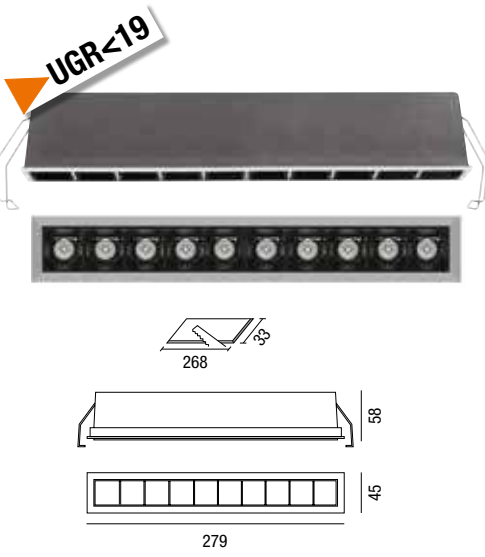

220-240V 50/60Hz **IK07** **IP20**

**Accessori non inclusi - Not included accessories**

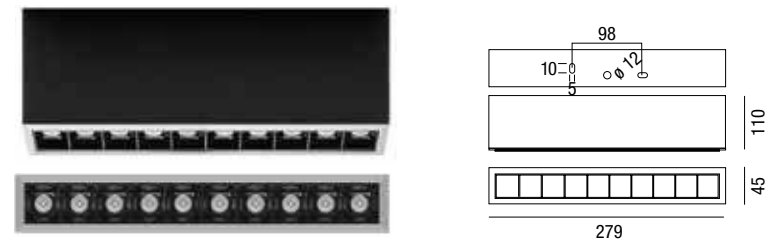

colour	W	mA max		lm output	K	pcs	Kg	S+L
<b>G N</b>	18	350	30°	1450	3000	001	0,45	28204

**Driver (non incluso) - LED Power supply (not included)**

SCEGLI LA GIUSTA CORRENTE PER OTTIMIZZARE IL FLUSSO LUMINOSO NECESSARIO  
 CHOOSE THE RIGHT CURRENT TO OPTIMIZE THE NECESSARY LUMINOUS FLUX

**LED driver multipower**

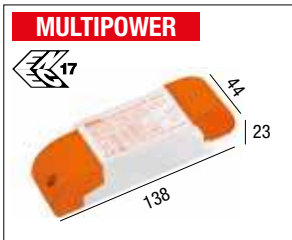

Cod. RN8167  
1050 mA max.

LED driver multipower   
RN8167 (ON-OFF)

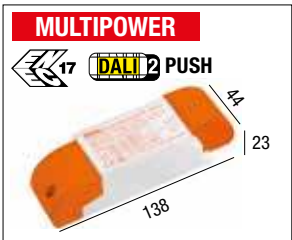

RN8166  
1050 mA max.

LED driver multipower   
RN8166 DALI 2 PUSH (DALI, PUSH, 0-10V.)

Taratura Dip-switch	Potenza Power
mA	Watt
150	7,5
200	10
250	10
300	15
350	17,5

Taratura standard di fabbrica  
Driver Standard factory setting

Recessed/ceiling







### LED Equal 4 R

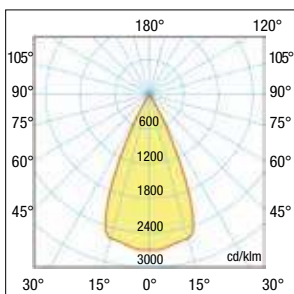

50°



	colour	W		lm output	K	Lm/W	pcs	Kg	CELL
	B	15	50°	1950	3000	130	001	0,50	29200W
	N	15	50°	1950	3000	130	001	0,50	29200B
	 B	15	50°	1950	3000	130	001	0,50	29200WDA
	 N	15	50°	1950	3000	130	001	0,50	29200BDA
	B	15	50°	1950	4000	130	001	0,50	29200W/4K
	N	15	50°	1950	4000	130	001	0,50	29200B/4K
	 B	15	50°	1950	4000	130	001	0,50	29200WDA/4K
	 N	15	50°	1950	4000	130	001	0,50	29200BDA/4K

A richiesta 2700K - 2700K On request

**UGR < 19**

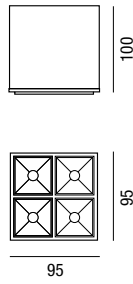

50°

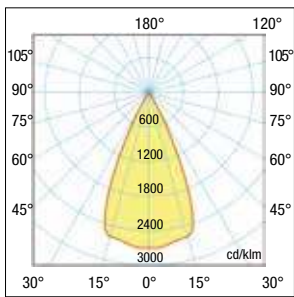

colour	W			lm output	K	pcs	Kg	CELL
<b>B</b>	15	Led SMD	50°	1950	3000	001	0,50	30200W
<b>N</b>	15	Led SMD	50°	1950	3000	001	0,50	30200B
<b>DALI 2</b> <b>B</b>	15	Led SMD	50°	1950	3000	001	0,50	30200WDA
<b>DALI 2</b> <b>N</b>	15	Led SMD	50°	1950	3000	001	0,50	30200BDA
<b>B</b>	15	Led SMD	50°	1950	4000	001	0,50	30200W/4K
<b>N</b>	15	Led SMD	50°	1950	4000	001	0,50	30200B/4K
<b>DALI 2</b> <b>B</b>	15	Led SMD	50°	1950	4000	001	0,50	30200WDA/4K
<b>DALI 2</b> <b>N</b>	15	Led SMD	50°	1950	4000	001	0,50	30200BDA/4K

A richiesta 2700K - 2700K On request







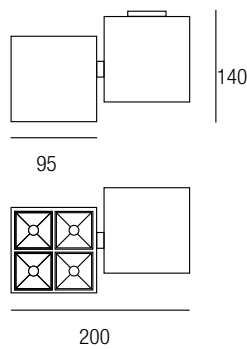
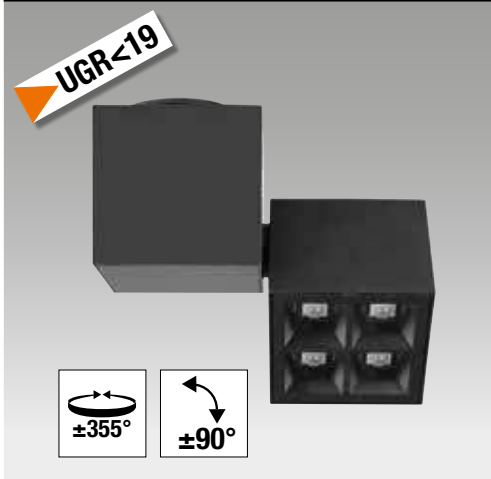

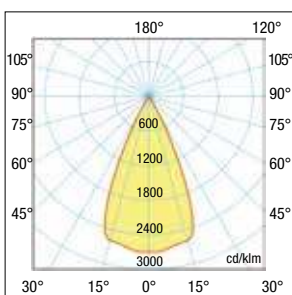

**LED Equal 4 CW double**



50°



colour	W		lm output	K	Lm/W	pcs	Kg	CELL
B	15	50°	1950	3000	130	001	0,70	33200W
N	15	50°	1950	3000	130	001	0,70	33200B
 B	15	50°	1950	3000	130	001	0,70	33200WDA
 N	15	50°	1950	3000	130	001	0,70	33200BDA
B	15	50°	1950	4000	130	001	0,70	33200W/4K
N	15	50°	1950	4000	130	001	0,70	33200B/4K
 B	15	50°	1950	4000	130	001	0,70	33200WDA/4K
 N	15	50°	1950	4000	130	001	0,70	33200BDA/4K

A richiesta 2700K - 2700K On request

## LED Ardito

Downlights progettati per illuminare spazi commerciali (supermercati, grandi magazzini, retail, ecc.), uffici e qualsiasi ambiente dove è necessaria un'illuminazione generale e d'accento.

**Installazione:** ad incasso in controsoffitti di cartongesso (completo di staffe di fissaggio).

**Corpo:** in lamiera di acciaio, verniciata con polvere termoidurente poliestere.

**Staffe di fissaggio:** in acciaio.

**Verniciatura:** di tipo poliestere eseguita a polvere. Colore bianco RAL 9010

**Optica:** parabola in alluminio semi concentrante 60°.

**Schermo:** in policarbonato semi-opale.

**Temperatura di colore:** 3000K - 4000K, 3CCT.

**Driver:** multipotenza (non incluso)  con selezione del dip switch per scegliere la tensione in uscita. Fattore di potenza  $\geq 0,95$ .

**Conforme alla norma:** EN60598-1, RG0 nessun rischio fotobiologico ai fini della norma EN62471.

**Led:** SAMSUNG mantenimento del flusso luminoso minimo al 80%: L80B20>50.000h.

**Prodotto conforme alle direttive:** 

*Downlights designed to light up retail spaces (supermarkets, department stores, shops, etc.), offices and any other place that requires general and spot lighting.*

**Installation:** recessed use in plasterboard false ceilings (complete with fixing brackets).

**Body:** made of sheet steel, painted with polyester thermosetting powder.

**Fixing brackets:** made by steel.

**Coating:** coated with powdered polyester. RAL 9010 white color.

**Optic:** 60° semi-diffused aluminum parabola 0° semi-clumping.

**Shield:** in semi-opal polycarbonate.

**Color temperature:** 3000K - 4000K, 3CCT.

**Driver:** multipower (not included)  with dip switch to choose the output voltage. Power factor  $\geq 0,95$ .

**According to standard:** EN60598-1, RG0 exempt from photo-biological risks in compliance with standard EN62471.

**Led:** SAMSUNG maintenance of minimum luminous flux to 80%: L80B20>50.000h.

**Product compliant with directives:** 

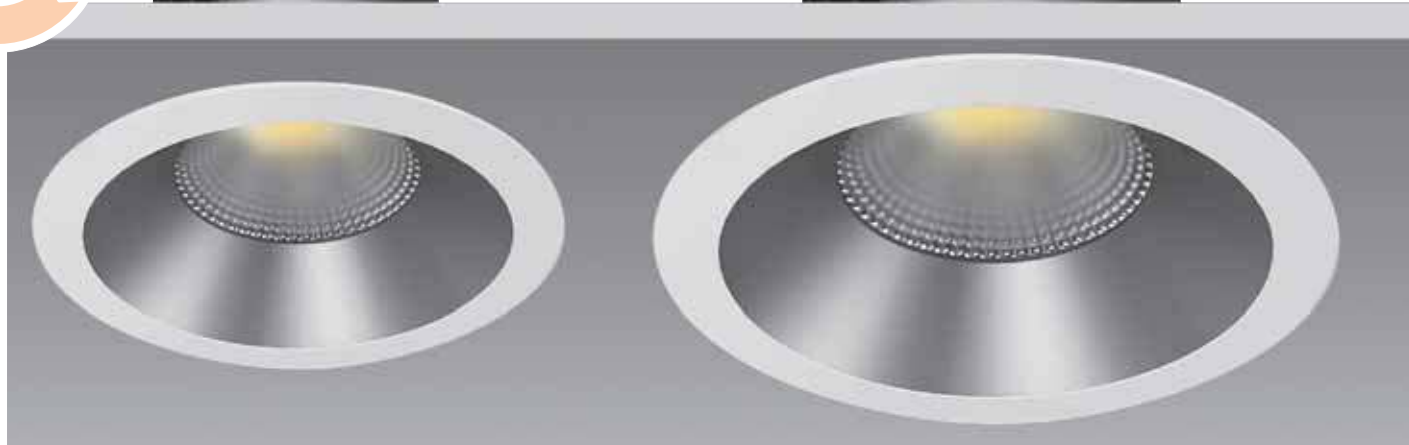

**3CCT SWITCHABLE**



Con cambio tonalità mediante selettore integrato posizionato sul corpo lampada è possibile scegliere la temperatura di colore preferita.

*With the integrated selector switch on the lamp body, you can choose your preferred color temperature.*

### UGR Indice di abbagliamento - Unified Glare Rating

UGR	Classificazione valori UGR in funzione delle applicazioni. <i>UGR value classification based on application.</i>
≤ 16	<b>Applicazioni molto impegnative</b> (disegni tecnici, lavoro a videoterminale). <b>Highly demanding applications</b> (technical drawings, working with video display terminals).
≤ 19	<b>Uffici e scuole</b> (lettura, scrittura, riunioni). <b>Offices and schools</b> (reading, writing, meetings).
≤ 22	Applicazioni industriali, artigianato. <i>Industrial, artisanal applications.</i>
>28	Abbagliamento elevato. <i>High glare.</i>

L'UGR è l'indicatore dell'abbagliamento diretto derivante dall'impianto di illuminazione. La norma Europea per l'illuminazione dei posti di lavoro in interni **UNI-EN12464-1** richiede un valore UGR specifico per ogni applicazione, compreso tra 10 e 30. Più è basso il valore, minore è l'abbagliamento.

*UGR is the indicator to assess the direct glare coming from a lighting system. The **UNI-EN12464-1** European standard for lighting indoor workplaces requires a specific UGR value for every application, ranging between 10 and 30. The lower the value, the lower the glare.*

A richiesta  
On demand



WIRELESS



IP20 IK06  
IP44 IK06

### LED Ardito 150

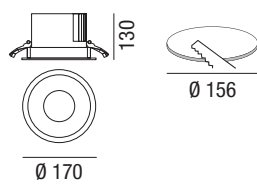
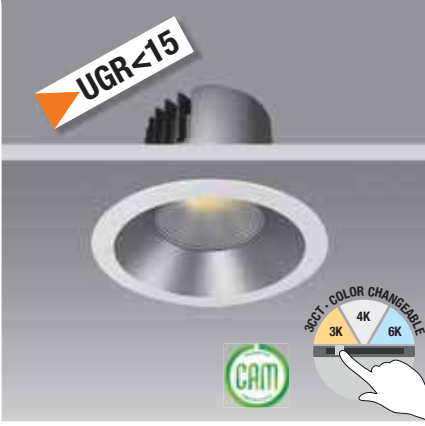

### LED Ardito 150 - 3CCT

3CCT  
SWITCHABLE

colour	W max	mA max	Beam angle	K	Lm output	pcs	Kg	S+L
B	30	700	60°	3000 4000 6000	max 3000	001	1.70	24320/150-

### LED Ardito 200

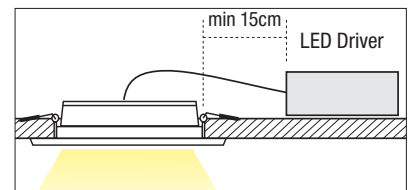
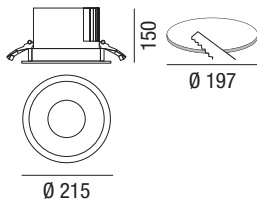

colour	W max	mA max	Beam angle	K	Lm output	pcs	Kg	S+L
B	30	700	60°	3000	max 3000	001	1.70	24319/200/B
B	30	700	60°	4000	max 3000	001	1.70	24320/200/B

### LED Ardito 200 - 3CCT

3CCT  
SWITCHABLE

colour	W max	mA max	Beam angle	K	Lm output	pcs	Kg	S+L
B	30	700	60°	3000 4000 6000	max 3000	001	1.70	24320/200-

### Tabella di scelta potenza driver LED (non incluso) - LED Power supply table choice (not included)



LED driver multipower



RN8167 - ON-OFF Taratura max 700mA  
RN8166 - DALI2 PUSH - Taratura max 700mA

Fornito di dip switch per la selezione della corrente in uscita. Il driver non è incluso nella confezione ed è normalmente settato al minimo. Se necessario è possibile aumentare la potenza e di conseguenza i lumen output senza superare i 700mA.

Equipped with dip switch for selecting the current output. The driver is not included inside the package and is normally set to minimum. If necessary it is possible to increase the power and consequently the lumen output without exceeding 700mA.

Taratura Dip-switch	Potenza Power	Lm Output
mA	Watt	Lm
500	21	2100
600	25	2500
650	27	2700
700	30	3000



Cod. RP0714CP3 - AUTOTEST  
L195x P55x H42  
Kit emergenza 3W - 3h/12% 180÷250 Vac  
180÷250 Vac - 3h/12% - 3W emergency kit

Cod. 65151LED80CP3  
L240x P59x H40  
Kit emergenza 3W - 3h/12% 180÷250 Vac  
180÷250 Vac - 3h/12% - 3W emergency kit

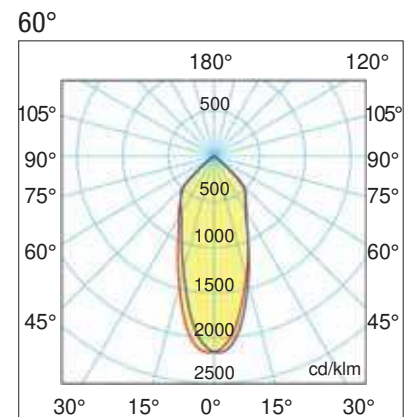

## LED Bazar

A RICHIESTA  
ON DEMAND



Apparecchi ad incasso progettati per illuminare aree comuni, corridoi, laboratori, sale riunioni, uffici e qualsiasi ambiente dove è necessaria un'illuminazione con ridotti livelli di abbagliamento.

**Installazione:** ad incasso per controsoffitti in cartongesso (completo di staffe di fissaggio).

**Corpo e telaio:** in lamiera di acciaio con faretto orientabili e basculanti.

**Staffe di fissaggio:** in acciaio nichelato.

**Verniciatura:** di tipo poliestere eseguita a polvere. Colore bianco RAL 9010

**Ottica:** parabola in alluminio diffondente.

**Temperatura di colore:** 3000K - 4000K.

**Driver multipotenza:** incluso.

Fattore di potenza  $\geq 0,95$ .

**Conforme alla norma:** EN60598-1, RG0 nessun rischio fotobiologico ai fini della norma EN62471.

**Led: SAMSUNG** mantenimento del flusso luminoso minimo al 80%: L80B20>50.000h.

*Recessed downlights designed to light up common areas, corridors, laboratories, meeting rooms, offices and any other place that requires diffused lighting with no glare effect.*

**Installation:** recessed use in plasterboard false ceilings (complete with fixing brackets)

**Body and frame:** in sheet steel with adjustable and tilting spotlights.

**Fixing brackets:** made by galvanized steel.

**Coating:** coated with powdered polyester.

RAL 9010 white color.

**Optic:** semi-diffused.

**Color temperature:** 3000K - 4000K.

**Driver multipower:** included.

Power factor  $\geq 0,95$ .

**According to standard:** EN60598-1, RG0 exempt from photo-biological risks in compliance with standard EN62471.

**Led: SAMSUNG** maintenance of minimum luminous flux to 80%: L80B20>50.000h.

### LED Bazar 1X25 - 1X40

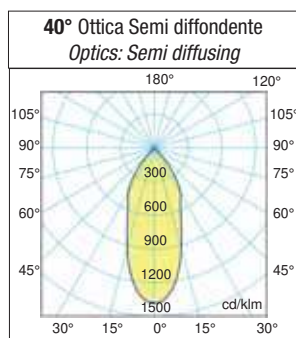
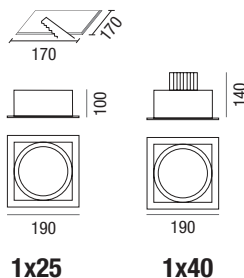

	colour	W max*	K	Lm output		on demand	pcs	Kg	CELL
	B	25	3000	2750	40°	25° - 60°	10	1.50	BZ125403K
	B	25	3000	2750	40°	25° - 60°	10	1.50	BZ125403KDA
	B	25	4000	2750	40°	25° - 60°	10	1.50	BZ125404K
	B	25	4000	2750	40°	25° - 60°	10	1.50	BZ125404KDA
	B	40	3000	4400	40°	25° - 60°	10	1.50	BZ140403K
	B	40	3000	4400	40°	25° - 60°	10	1.50	BZ140403KDA
	B	40	4000	4400	40°	25° - 60°	10	1.50	BZ140404K
	B	40	4000	4400	40°	25° - 60°	10	1.50	BZ140404KDA

\*Driver multipotenza incluso, è possibile se necessario, ridurre i Lm Output.  
*Multipower driver included, it is possible if necessary, to reduce the Lm Output.*

### A richiesta - On request

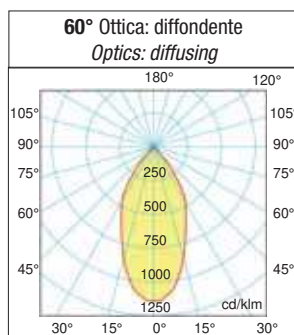
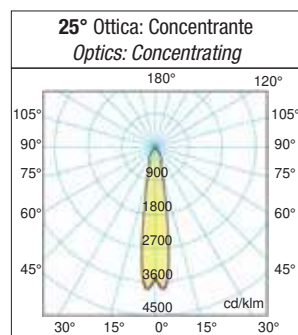

**Cod. 65151LED80CP3**  
Kit emergenza 3W -3h/12% 180÷250 Vac  
180÷250 Vac - 3h/12% emergency kit 3W

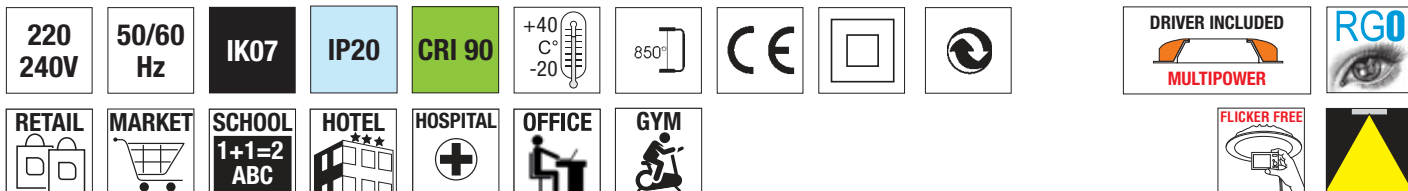

**LED Bazar 2x25 -2X40**

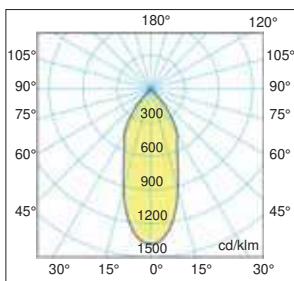
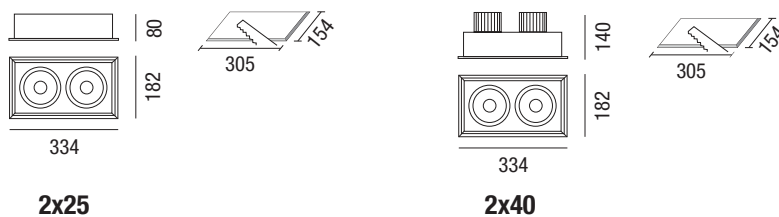

colour	W max*	Beam angle	on demand	lm output	K	pcs	Kg	CELL
B	2x25	40°	25° - 60°	max 5000	3000	001	2	BZ225403K
<b>DALI 2</b>	B	2x25	40°	25° - 60°	max 5000	3000	001	BZ225403KDA
B	2x25	40°	25° - 60°	max 5000	4000	001	2	BZ225404K
<b>DALI 2</b>	B	2x25	40°	25° - 60°	max 5000	4000	001	BZ225404KDA
B	2x40	40°	25° - 60°	max 8000	3000	001	2,5	BZ240403K
<b>DALI 2</b>	B	2x40	40°	25° - 60°	max 8000	3000	001	BZ240403KDA
B	2x40	40°	25° - 60°	max 8000	4000	001	2,5	BZ240404K
<b>DALI 2</b>	B	2x40	40°	25° - 60°	max 8000	4000	001	BZ240404KDA

\*Driver multipotenza incluso, è possibile se necessario, ridurre i Lm Output.  
*Multipower driver included, it is possible if necessary, to reduce the Lm Output.*

**Driver LED incluso - Included LED Power supply**



Fornito di dip switch per la selezione della corrente in uscita. Se necessario diminuire (NO AUMENTARE) la potenza e di conseguenza i lumen output.

**Equipped with dip switch for selecting the current output. If necessary, decrease (NO INCREASE) the power and consequently the lumen output.**

**Accessorio non incluso - Not included accessory**

Accessorio cassaforma esterna per montaggio a soffitto, lo spazio è idoneo per alloggiare il Driver compreso con la lampada.

*External formwork accessory for ceiling mounting, the space is suitable for housing the Driver included with the lamp.*

Cod. CBZ1



Cod. CBZ2



Recessed

**LED Regina R 2CCT**A RICHIESTA  
ON DEMAND**WIRELESS****DALI 2****2CCT**  
COLOUR  
CHANGING

Apparecchi ad incasso progettati per illuminare sale riunioni, uffici, negozi, cucine e qualsiasi ambiente dove è necessaria un'illuminazione potente e direzionabile.

**Installazione:** ad incasso per controsoffitti in cartongesso (completo di staffe di fissaggio).

**Corpo e telaio:** in alluminio pressofuso UNI 5076 verniciato con polvere termoindurente poliestere.

**Orientabilità:** il corpo è estraibile ed orientabile su due assi, rispettivamente di Z=360°, Y=68°.

**Staffe di fissaggio:** in alluminio.

**Verniciatura:** di tipo poliestere eseguita a polvere. Colore bianco RAL 9010, nero RAL 9005.

**Ottica:** 40° riflettore in policarbonato.

**Schermo:** lastra in tecnopolimero trasparente.

**Temperatura di colore:** 2CCT 3000K e 4000K.

**Driver multipotenza:**  non incluso. Fattore di potenza  $\geq 0,95$ .

**Conforme alla norma:** EN60598-1, RG0 nessun rischio fotobiologico ai fini della norma EN62471.

**Prodotto conforme alle direttive:** 

*Recessed downlights designed to light up common areas, meeting rooms, offices, shops, kitchens, and any other place that requires diffused lighting powerful and directional.*

**Installation:** recessed use in plasterboard false ceilings (complete with fixing brackets)

**Body and frame:** made by UNI 5076 die-cast aluminum, coated with polyester thermoset powder.

**Adjustability:** Pull-out light Head pivot through Y=68°, rotates through Z=360°.

**Fixing brackets:** made by aluminum material.

**Coating:** coated with powdered polyester.

RAL 9010 white color or RAL 9005 black color.

**Optic:** 40° polycarbonate Reflector.

**Shield:** transparent engineering polymer sheet.

**Color temperature:** 2CCT 3000K e 4000K.

**Driver multipower:**  not included. Power factor  $\geq 0,95$ .

**According to standard:** EN60598-1, RG0 exempt from photo-biological risks in compliance with standard EN62471.

**Product compliant with directives:** 



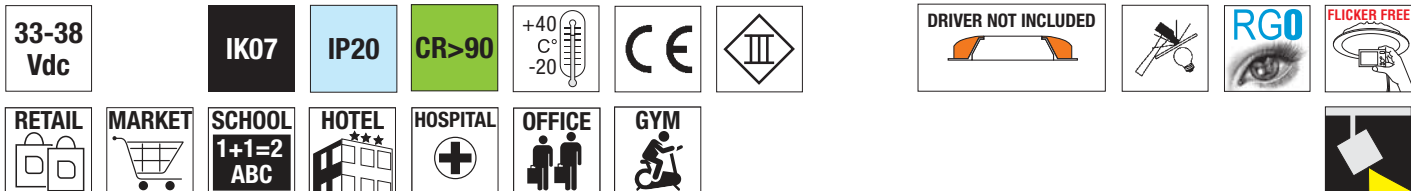

**LED Regina R 2CCT**

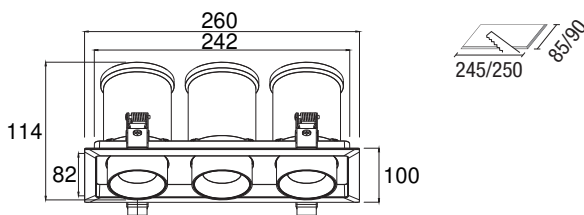

colour	W max	I max	lm output max	K	Pcs	Kg	S+L
<b>N</b>	<b>3x14 (42)</b>	3x350 mA	3400	3000	4000	6	329402CCT
<b>B</b>	<b>3x14 (42)</b>	3x350 mA	3400	3000	4000	6	329412CCT

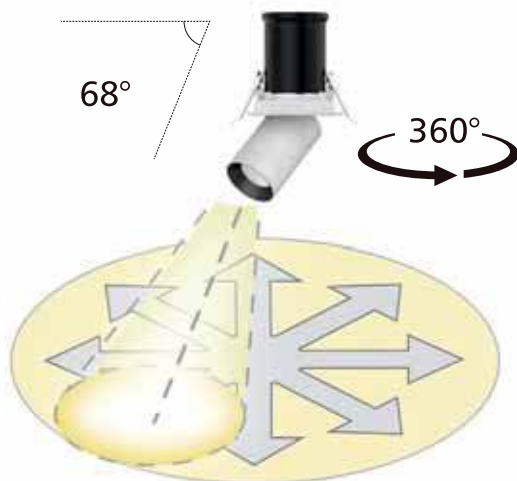
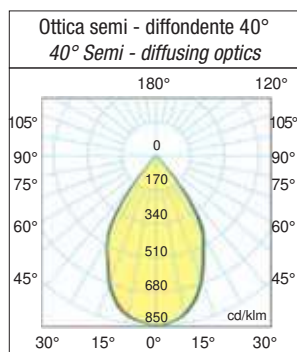

Zubehör nicht im Lieferumfang enthalten - Accessoires non compris



**LED driver multipower**

3X - RN8167 350mA (ON-OFF)  
3X - RN9152 350mA (ON-OFF)  
3X - RN8166 350mA **DALI 2** PUSH



**Cod. 65151LED80CP3**  
Kit emergenza 3W - 3h/12% 180÷250 Vac  
180÷250 Vac - 3h/12% - 3W emergency kit

**Cod. RP0714CP3 - AUTOTEST**  
Kit emergenza 3W - 3h/12% 180÷250 Vac  
180÷250 Vac - 3h/12% - 3W emergency kit

**Tabella di scelta potenza driver LED - LED Power supply table choice**

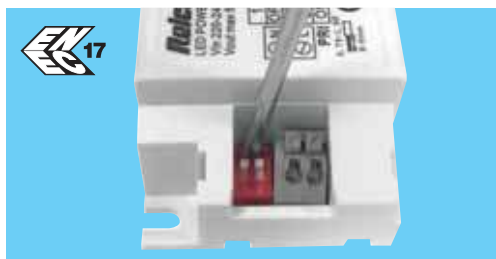

Fornito di dip switch per la selezione della corrente in uscita. Il driver incluso nella confezione.

Equipped with dip switch for selecting the current output. The driver included inside the package.

Taratura Dip-switch	Potenza Power	Lm Output
mA	Watt	Lm
3x250	3x11	3300
3x350	3x16	4200

Recessed

## LED Otto IP44

A RICHIESTA  
ON DEMAND



### Otto LED 3 lampade in una!

Apparecchi da incasso progettati per illuminare aree comuni, corridoi, laboratori, sale riunioni, uffici e qualsiasi ambiente dove è necessaria un'illuminazione diffusa. La struttura del faretto è a base tonda, ideale per sostituire apparecchi con sorgenti fluorescenti compatte.

**Installazione:** ad incasso in controsoffitti di cartongesso (completo di staffe di fissaggio).

**Corpo e telaio LED Otto T3 - T4 - T5:** in tecnopolimero ad alta resistenza.

**Staffe di fissaggio e viteria:** in acciaio.

**Verniciatura:** di tipo poliestere eseguita a polvere. Colore bianco RAL 9010.

**Ottica:** diffusore.

**Schermo:** in lastra tecnopolimero opale.

**Temperatura di colore:** LED Otto T3 e T4 con possibilità di scelta tra tre diverse temperature di colore, bianco caldo, bianco neutro o bianco freddo (3CCT).

LED Otto T5 3000K o 4000K.

**Driver:** incluso.

**Conforme alla norma:** EN60598-1, RG0 nessun rischio fotobiologico ai fini della norma EN62471.

### Otto LED 3 lamps in one!

Recessed downlights designed to light up common areas, corridors, laboratories, meeting rooms, offices and any other place that requires diffused lighting. The luminaire structure is round, ideal to replace fixtures with compact fluorescent lamps.

**Installation:** recessed use in plasterboard false ceilings (complete with fixing brackets).

**LED Otto T3 - T4 - T5 body and frame:** made by engineering polymer with high resistance.

**Fixing brackets and screws:** made by steel.

**Coating:** coated with powdered polyester. RAL 9010 white color.

**Optic:** diffused.

**Shield:** opal engineering polymer sheet.

**Color temperature:** LED Otto T3 and T4 with the possibility of choosing between three different color temperatures, warm white, neutral white or cold white (3CCT).

LED Otto T5 3000K or 4000K.

**Driver:** included.

**According to standard:** EN60598-1, RG0 exempt from photo-biological risks in compliance with standard EN62471.

220 240V	50/60 Hz	IK07	IP44	CRI>80	+40 C° -20	850°	CE			DRIVER INCLUDED	RG0
-------------	-------------	------	------	--------	------------------	------	----	--	--	-----------------	-----

### LED Otto T5 Adjustable

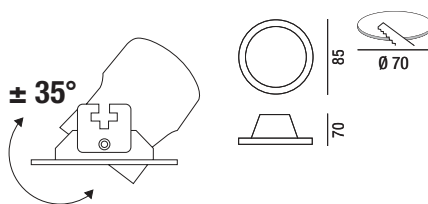

Regolabile / Adjustable



colour	W	Beam angle	lm output	K	pcs	Kg	Box	CELL
B	9	38°	990	3000	001	0.33	60 pcs	24922/3000
B	9	38°	990	4000	001	0.33	60 pcs	24922



### LED Otto T3

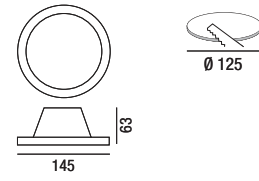
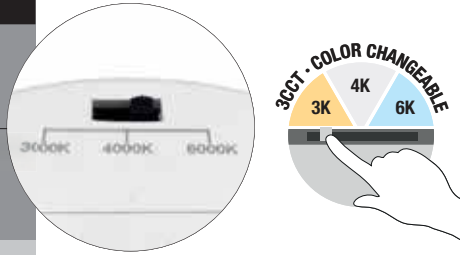

colour	W	Beam	lm output	K			pcs	Kg	Box	CELL
B	12	100°	1320	3000	4000	6000	001	0.30	40 pcs	25923/3-4-6K

### LED Otto T4

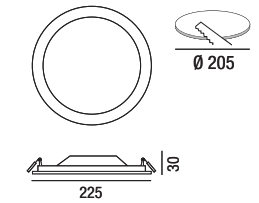
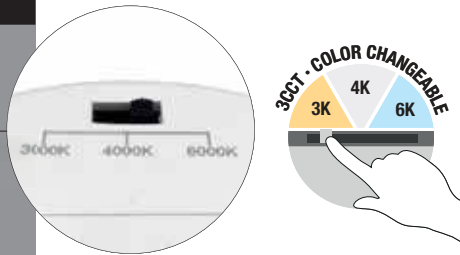

colour	W	Beam	lm output	K			pcs	Kg	Box	CELL
B	25	100°	2750	3000	4000	6000	001	0.40	20 pcs	25924/3-4-6K

### Accessori non inclusi - Not included accessories

Otto LED T4 accessorio per plafone  
Otto LED T4 ceiling accessory

Colour	pcs	H. mm	Ø mm	Code
B	001	33	230	25924/PL

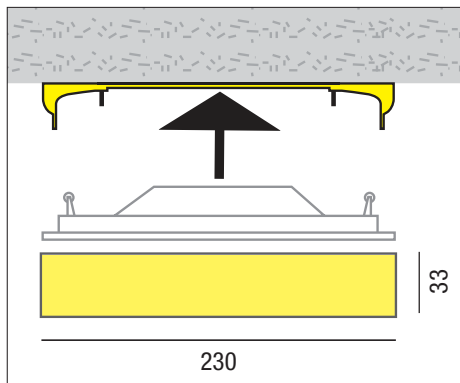

### Kit d'emergenza Emergency kit

**LED Otto T3** Cod. 65151LED80CP3  
Kit emergenza 3W - 3h/12% 180÷250 Vac  
180÷250 Vac - 3h/12% - 3W emergency kit

**LED Otto T4+T5** Cod. RP0714/OTTO + 00PB0530-N / **AUTOTEST**  
Kit emergenza 3W - 3h/12% 180÷250 Vac  
180÷250 Vac - 3h/12% - 3W emergency kit



## LED Nove C-R IP44



### LED Nove 6 lampade in una!

Plafoniere da incasso o plafone "Super Slim" 3CCT con possibilità di scelta tra tre differenti potenze, progettate per illuminare aree comuni, corridoi, laboratori, sale riunioni, uffici e qualsiasi ambiente dove è necessaria un'illuminazione diffusa. La struttura dei faretto è a base tonda, in 3 misure, ideali per sostituire apparecchi con sorgenti fluorescenti compatte, fornito di staffe scorrevoli in acciaio con molle che si adattano a fori già esistenti da da Ø65 a Ø310mm.

**Installazione:** a plafone, incasso in controsoffitti di cartongesso (complete di staffe di fissaggio che si adattano a fori di diversi diametri da Ø65 a Ø310mm) e sospensione con accessori inclusi.

**Corpo e telaio:** in tecnopolimero ad alta resistenza.

**Staffe di fissaggio e viteria:** in acciaio.

**Verniciatura:** di tipo poliester e eseguita a polvere. Colore bianco RAL 9010.

**Ottica:** diffondente.

**Schermo:** in lastra tecnopolimero opale.

**Cornici:** in metallo, magnetiche di colore Bianco, Nero, Nikel (da ordinare a parte).

**Temperatura di colore:** con possibilità di scelta tra tre diverse temperature di colore, bianco caldo, bianco neutro o bianco freddo.

**Driver:** incluso.

**Conforme alla norma:** EN60598-1, RG0 nessun rischio fotobiologico ai fini della norma EN62471.

### LED Nove 6 lamps in one!

3CCT "Super Slim" recessed or surface-mounted ceiling lights with the possibility of choosing between three different powers, designed to illuminate common areas, corridors, laboratories, meeting rooms, offices and any environment where diffused lighting is required.

The structure of the spotlight has a round base, ideal for replacing fixtures with compact fluorescent sources, supplied with sliding steel brackets with springs that adapt to existing holes from Ø65 to Ø310mm.

**Installation:** surface mounted, recessed in plasterboard false ceilings (complete with fixing brackets that adapt to holes of different diameters from Ø65 to Ø310mm) and suspended with accessories included.

**Body and frame:** in high resistance technopolymer.

**Fixing brackets and screws:** in steel.

**Painting:** polyester type made with powder. RAL 9010 white colour.

**Optics:** diffusing.

**Screen:** in opal technopolymer plate.

**Frames:** in metal, magnetic in White, Black, Nikel (to be ordered separately).

**Color temperature:** with the choice of three different color temperatures, warm white, neutral white or cool white.

**Drivers:** included.

**Compliant with standard:** EN60598-1, RG0 no photobiological risk for the purposes of standard EN62471.



**2 in 1 + 6 in 1**

**soffitto e incasso ceiling or recessed**

Montaggio a soffitto  
Surface-mounted

Montaggio ad incasso  
Recessed-mounted

Super sottile  
Super slim

Cornici non incluse  
not included Frames

Cornice bianca inclusa  
White frame included

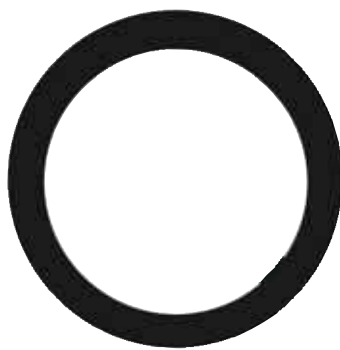

Code: 001Black - Ø 225mm  
Code: 002Black - Ø 300mm





### LED Nove C-R 225

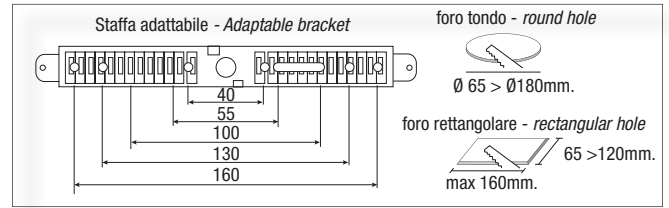
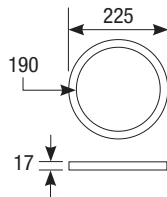

colour	W	Im output	K			pcs	Kg	CELL	
B	6	500	3000	4000	6000	001	0.30	20 pcs	NOVE-18
	12	1000							
	18	1500							

### LED Nove C-R 300

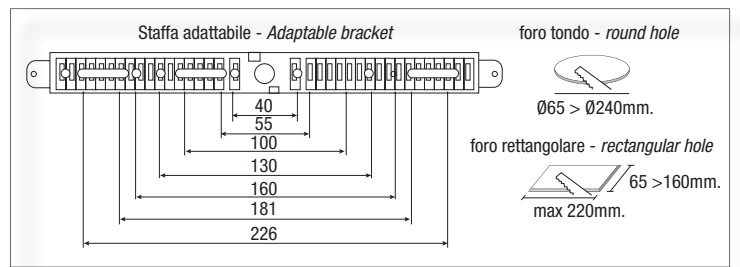
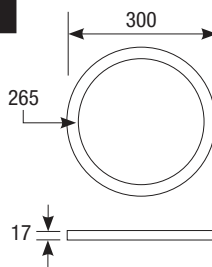

colour	W	Im output	K			pcs	Kg	CELL	
B	20	1600	3000	4000	6000	001	0.45	10 pcs	NOVE-28
	24	1920							
	28	2380							

### Accessori inclusi - Included accessories

Staffe adattabili per fori quadrati  
Brackets adaptable for square holes

Staffe adattabili per fori tondi  
Brackets adaptable for round holes

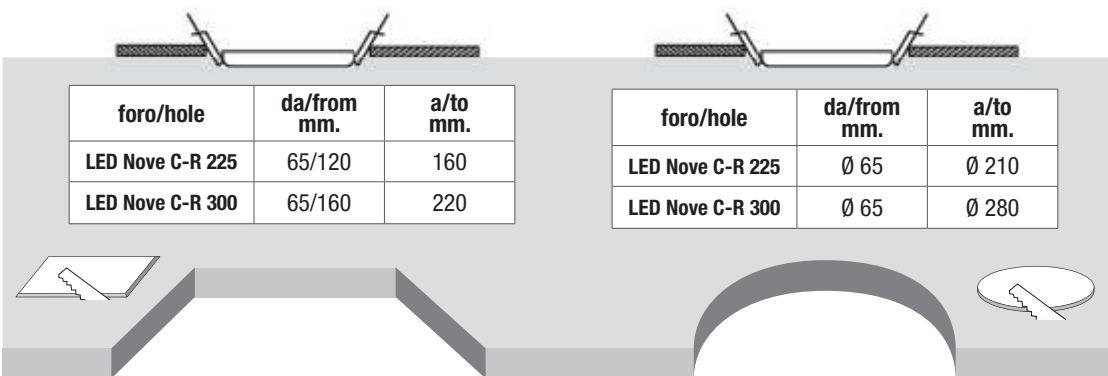

Molle scorrevoli  
Slidable springs

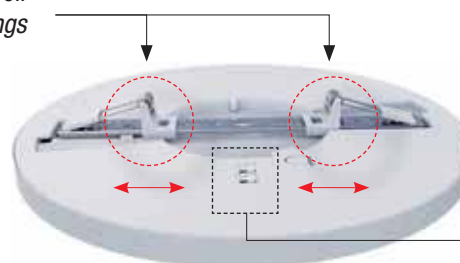
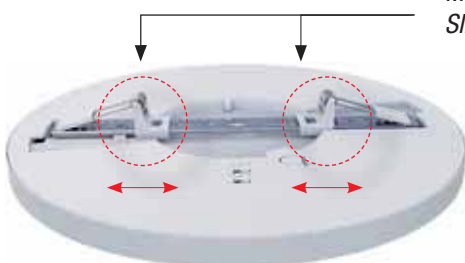

**6in1**

3CCT - COLOR CHANGEABLE  
3K 4K 6K

POWER CHANGEABLE  
W W W

eco series

Recessed

# LINEAR RECESSED Professional

Serie di apparecchi a LED lineari da incasso in diverse misure, dalle dimensioni più compatte per creare giochi di luce di grande effetto a dimensioni più ampie con schermo opale oppure con schermo dark light con UGR<16 per uffici, reception. Facilmente installabile anche in linea continua tramite gli accessori di giunzione (non inclusi).

Collegamento rapido con morsetto fast.

Disponibili in versione DALI, 0-10V.

**Corpo:** alluminio estruso anodizzato.

**Ottica :** in policarbonato opale.

**Ottica dark Light:** parabola in alluminio 99,85, antiriflesso UGR<16 e antiridescenza a bassissima luminanza.

**Conforme alla norma:** EN60598-1, RG0 nessun rischio fotobiologico ai fini della norma EN62471.

**Prodotto conforme alle direttive:** 

*Straight LED fixtures with compact dimensions for flush mounting with opal screen, which can be easily installed in a continuous line by means of the junction accessories for continuous lines (not included), quick connection with fast terminal. Available in DALI version, 0-10V.*

**Body:** anodised extruded aluminium.

**Optics:** in opal polycarbonate.

**Dark light optics:** 99.85 aluminium parabola, antiglare UGR<16 and anti-iridescent, with very low luminance.

**Compliant with standard:** EN60598-1, RG0 no photobiological risk for the purposes mentioned in standard EN62471.

**Product compliant with directives:** 



Syros slim system R - Dark Light



Infinity -Dark Light

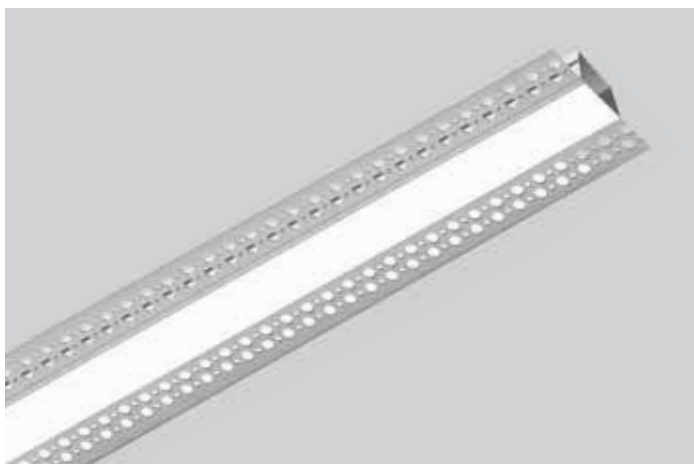

Trim 50 R - Opal

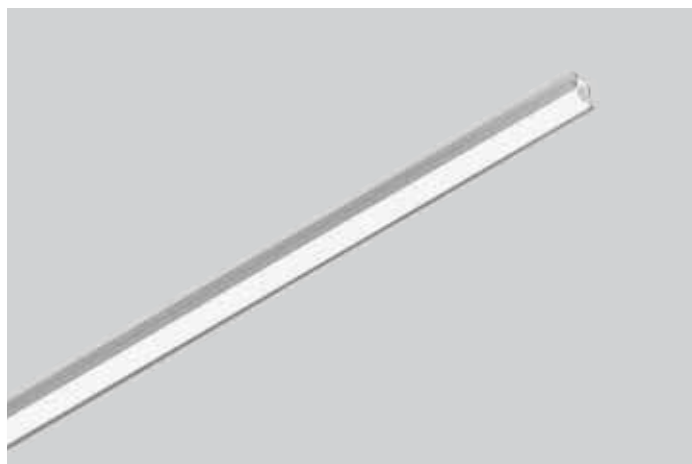

Trim R - Opal

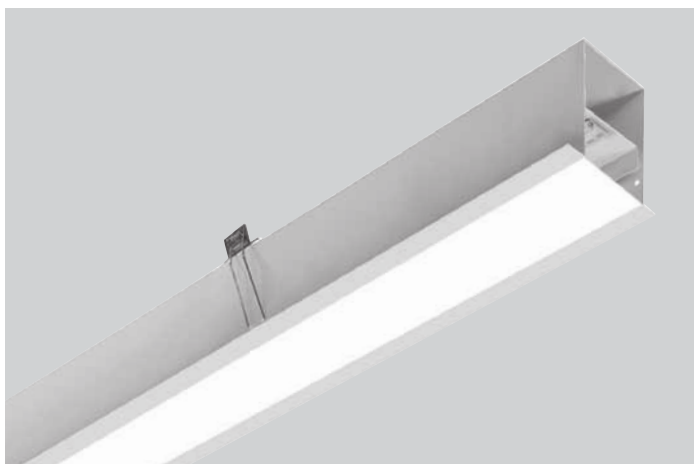

Creta RS - Opal

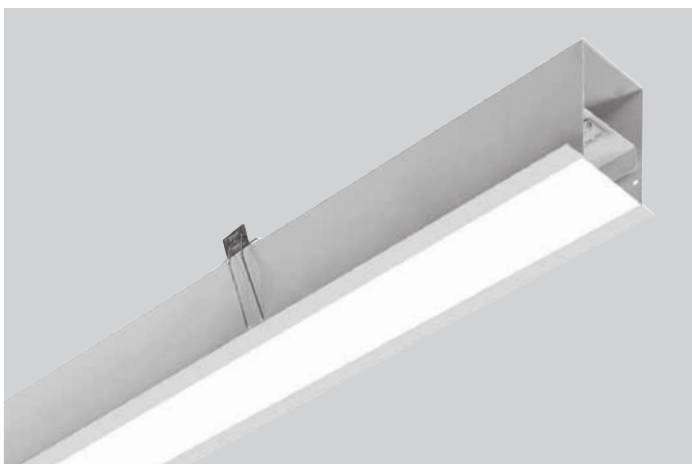

Rodi RS - Opal

# LINEAR RECESSED Professional

## LED Trim R Opal

Apparecchio singolo e fila continua  
Single devices and continuous line

A richiesta  
On demand **EMERGENCY**

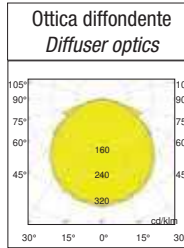
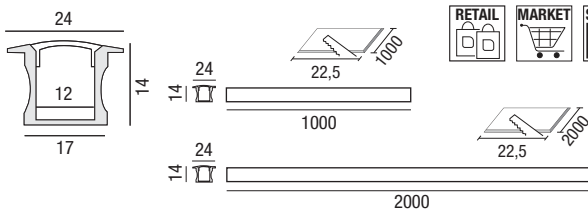
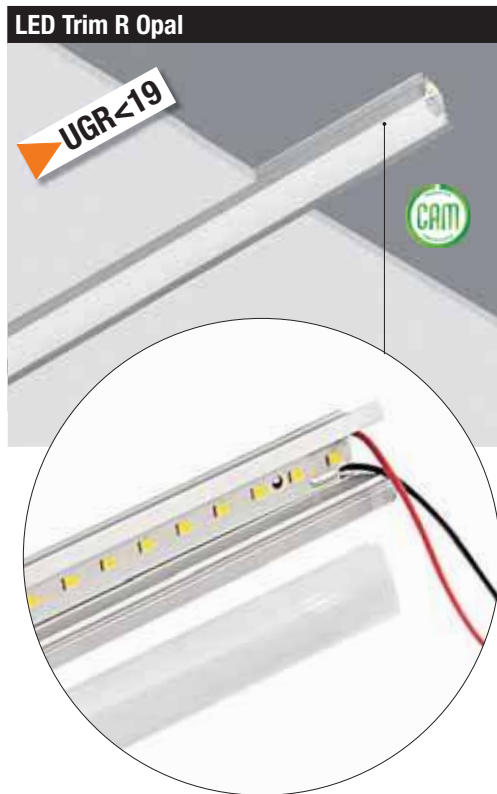

**DRIVER NOT INCLUDED** **CRI 90** +40 C° -20 C° **RG0**

colour	W max	IP	Imax	Im	K	L [mm]	Kg	?	S+L
S	20	20	900 mA	2300	4000	1000	0.185	5 pcs	20070-1/PLUS
S	20	20	900 mA	2300	3000	1000	0.185	5 pcs	20070-1/PLUS3
S	40	20	900 mA	4600	4000	2000	0.370	5 pcs	20070-2/PLUS
S	40	20	900 mA	4600	3000	2000	0.370	5 pcs	20070-2/PLUS3

La confezione include 5 pezzi, il prezzo è riferito ad una singola lampada.  
The package includes 5 pieces, the price refers to a single lamp.

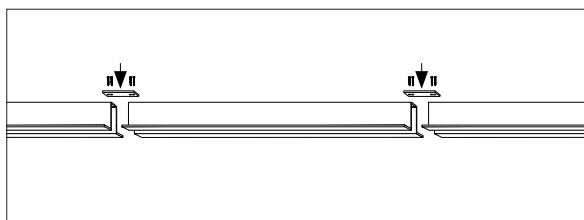

Possibilità di collegamento in linea continua tramite l'accessorio Kit giunto lineare **incluso nella confezione**.  
Possibility of series connection to create a continuous row using the accessory linear joint kit **included in the packaging**.

### Esempio applicativo - Application example

**Incluso di:** molle di fissaggio in lamiera di acciaio zincata e giunto lineare (2pcs) in lamiera di acciaio zincata, che permette di realizzare una giunzione di due corpi illuminanti in fila continua (fissaggio con viti).  
**Included:** fixing springs kit in galvanised steel sheet, Linear coupler kit (2 pcs) In galvanised steel sheet, fixing with screws. It allows a junction to be created, of two lighting fixtures in a continuous row.

### Accessori non inclusi - Not included accessories

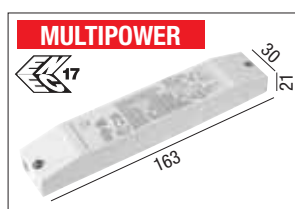

Cod. RN7136  
150-900mA

DRIVER:  
**DALI 2 PUSH**

Cod. RN7136DA  
150-900mA

Per versione L.1000  
For L.1000 version

Per versione L.2000  
For L.2000 version



Cod. 20070/T  
**Kit tappi di chiusura (2pcs)**  
In materiale termoplastico.  
**Closure caps kit (2pcs)**  
Thermoplastic material.

Recessed

# LED Trim 50 R Opal

Apparecchio singolo e fila continua  
*Single devices and continuous line*

A richiesta  
*On demand*



Recessed

# LINEAR RECESSED Professional



LED Trim 50 R Opal

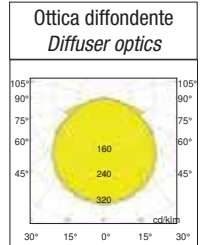
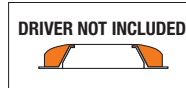
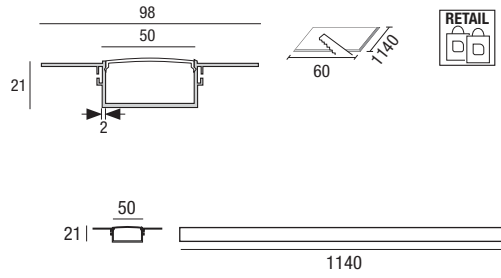
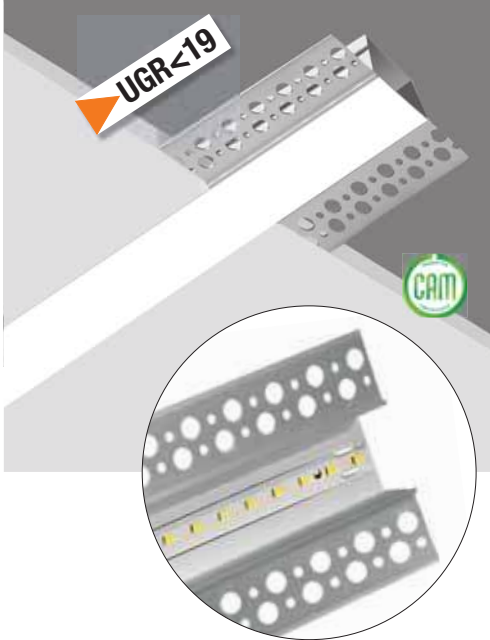

colour	W max	IP	Imax	Im	K	Kg		S+L
S	40	20	950 mA	4600	4000	0.185	5 pcs	20073-5/PLUS
S	40	20	950 mA	4600	3000	0.185	5 pcs	20073-5/PLUS3



Recessed

## Accessori non inclusi - Not included accessories

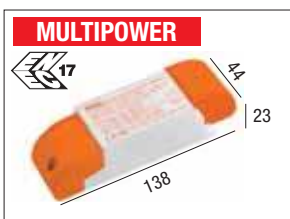

Cod. RN8167  
Cod. RN8166



Cod. 20073/C  
(2pcs)  
**Kit giunto lineare a scomparsa**  
In lamiera di acciaio zincato,  
fissaggio con viti.  
**Retractable linear coupler kit**  
In galvanised steel sheet,  
fixing with screws.

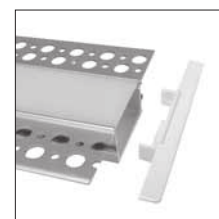

Cod. 20073/T  
(2pcs)  
**Kit tappi di chiusura**  
In materiale termoplastico  
Bianco RAL 9010  
**Closure caps kit**  
Thermoplastic material  
white RAL 9010

## Syros slim system R

Apparecchio singolo e fila continua  
*Single devices and continuous line*

A RICHIESTA  
ON DEMAND

0-10V

DALI 2

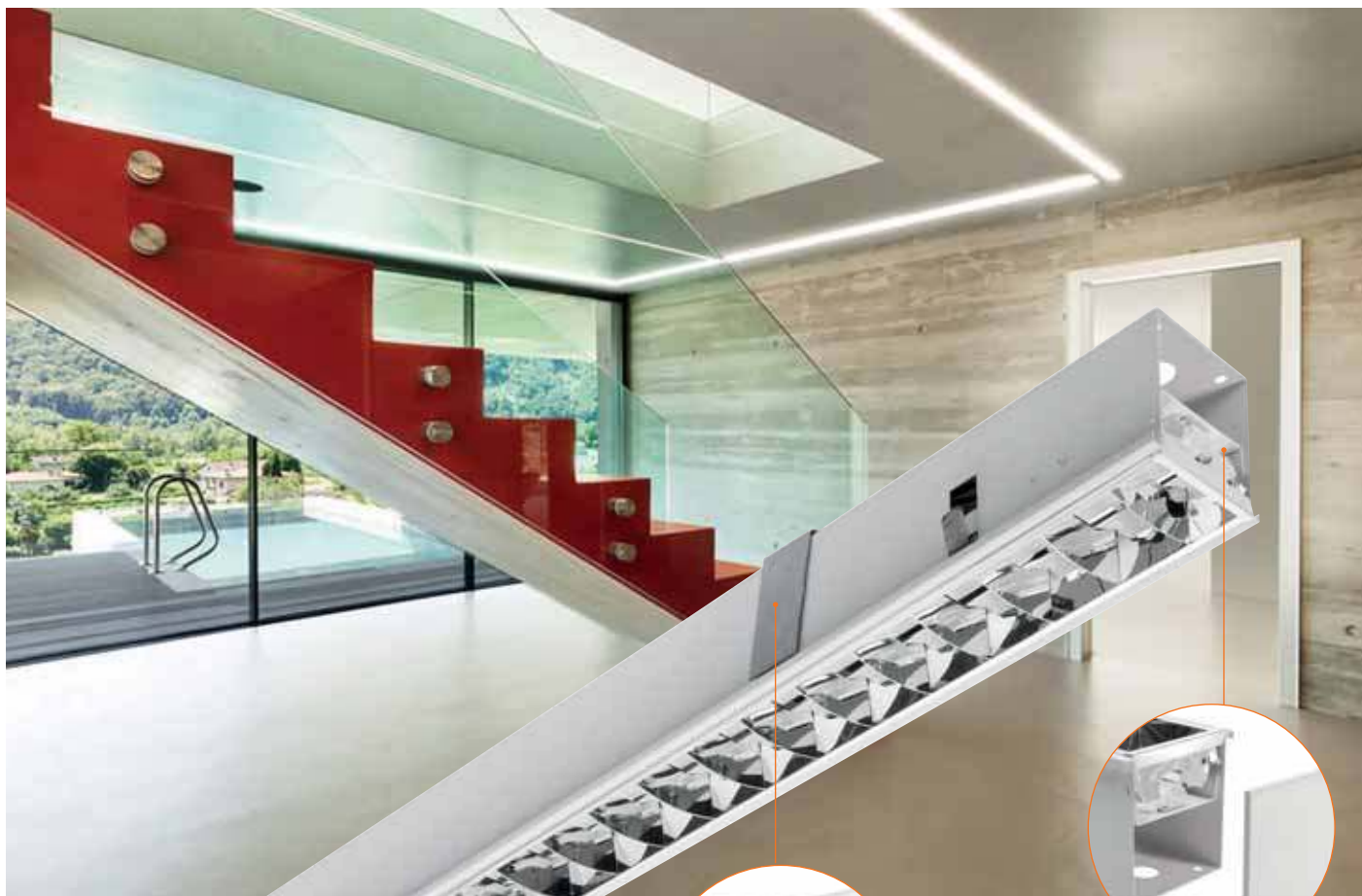

**Cod. 25804/Endcaps**  
Coppia di testate in policarbonato bianco con fissaggio a pressione.  
*Pair of white polycarbonate heads with pressure fixing.*

Con molle regolabili per l'incasso  
*With adjustable springs for flush mounting*

**Cod. 25803/SL**  
Collegabile in serie, a scomparsa semplice e stabile.  
*Connectable in series, simple and stable retractable.*

Connessione Fast di serie.  
*Fast connection as per standard.*

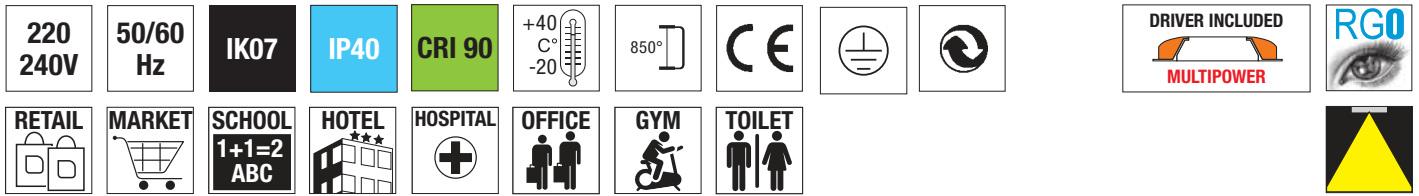

### Syros slim system R - Dark light

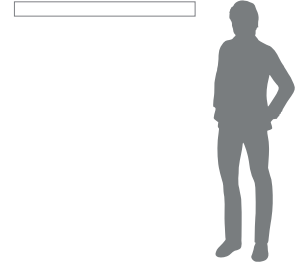
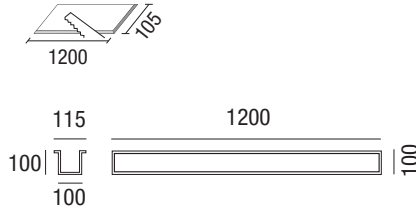
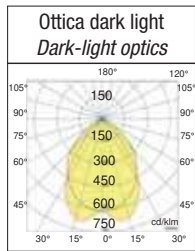

	colour	W max	Vac	lm output	lm/W	K	pcs/pallets	Kg	CELL
	B	40	220-240	5100	127	4000	60	4.50	25933/SL
	B	40	220-240	5100	125	4000	60	4.50	25933/SL/DALI
	B	60	220-240	7200	120	4000	60	4.50	25934/SL
	B	60	220-240	7200	120	4000	60	4.50	25934/SL/DALI

Per lampade cablate in emergenza (aggiungere /EM dopo il codice) sovrapprezzo del 20%.  
For wired emergency lights (add /EM after the code) 20% extra charge.

## Syros slim system R installazione - installation

### 3S Syros slim system R - Incasso / recessed

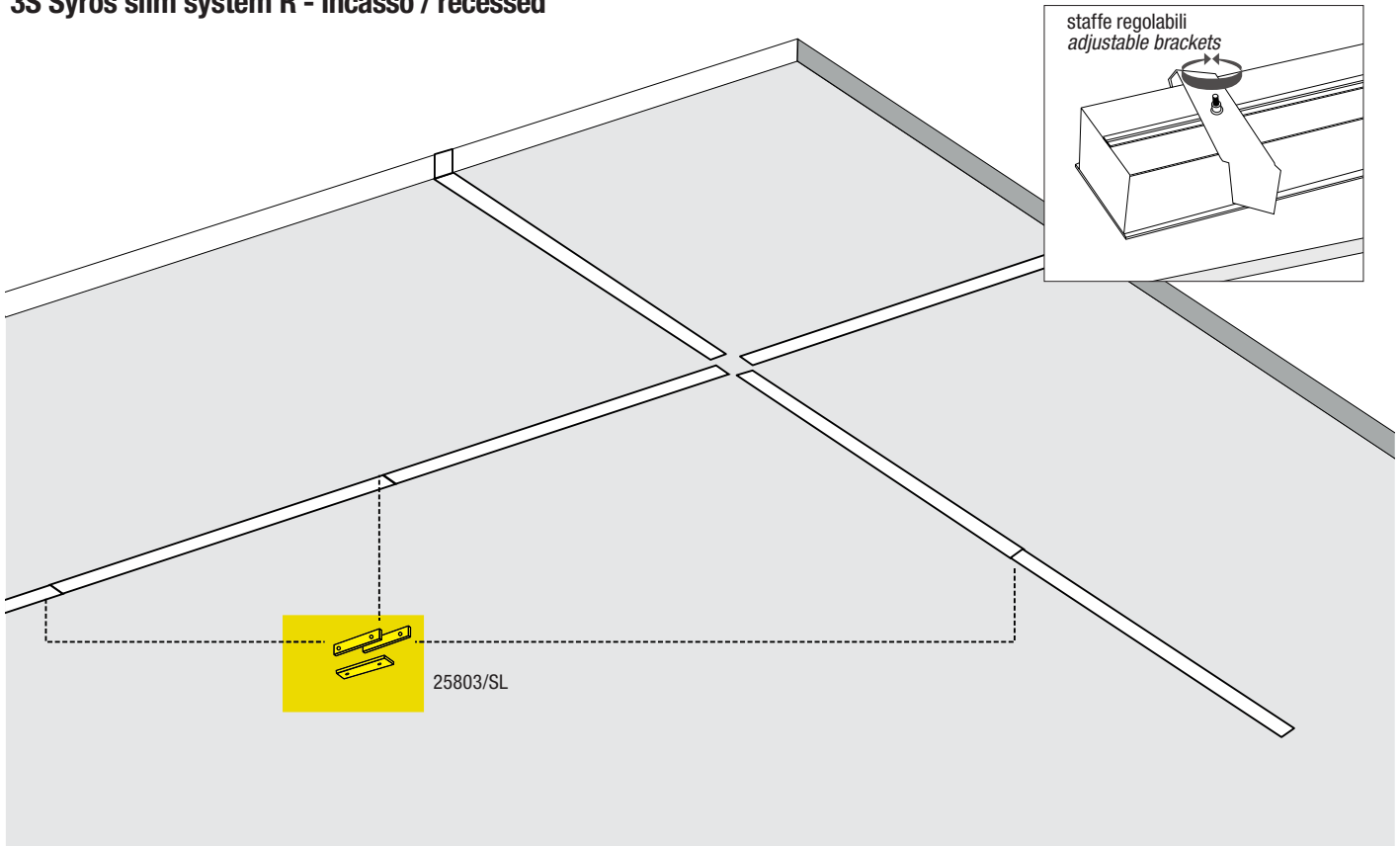

Recessed

## Infinity system R

Apparecchio singolo e fila continua  
Single devices and continuous line

A RICHIESTA  
ON DEMAND

0-10V

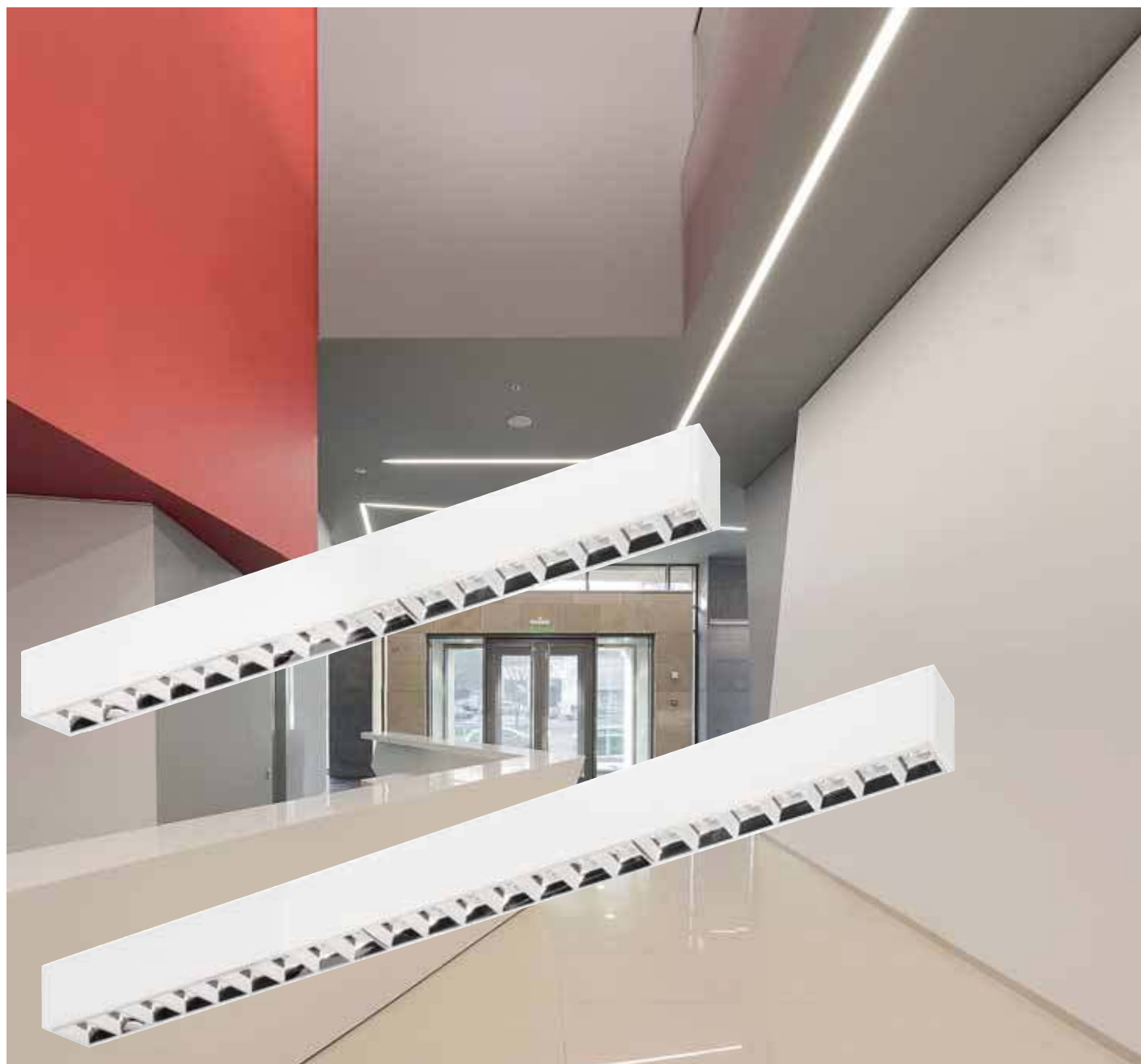

### LED Infinity R dark light.

Sistema luminoso modulare per file continue a sospensione o plafone, ideale uffici, reception, supermarket, palestre. Elementi di giunzione di semplice utilizzo per linee continue, la lampada è già predisposta di serie con cablaggio per fila continua.

Collegamento rapido con morsetto fast.

**A richiesta modello Biemissione.**

**Installazione:** ad incasso.

**Corpo:** alluminio estruso anodizzato al naturale verniciato (goffrato) a polveri epossidiche bianco RAL 9010.

**Incluso di molle di fissaggio in lamiera di acciaio zincata.**

**Optica comfort dark:** simmetrica 65° in policarbonato metallizzato anti-abbagliamento per un miglior confort visivo.

**Conforme alla norma:** EN60598-1, RG0 nessun rischio fotobiologico ai fini della norma EN62471.

**Led:** Lumileds SMD CR190 mantenimento del flusso luminoso minimo L80B20>50.000h.

**Driver multipotenza:** Incluso > 50.000 h Fattore di potenza ≥0,95, con dip switch accessibile per poter diminuire i W e di conseguenza i Lm.

**A richiesta:** per quantità si esegue il settaggio dedicato della corrente del Driver e di conseguenza la potenza di W e Lm.

**Prodotto conforme alle direttive:**

### LED Infinity R dark light.

Modular lighting system for continuous lines suspended or ceiling, ideal for offices, receptions, supermarkets, gyms. Easy-to-use connection elements for continuous lines, the lamp is already set up as standard with wiring for continuous lines.

Quick connection with fast terminal.

**On request Bi-emission model.**

**Installation:** recessed.

**Body:** natural anodised extruded aluminium painted (Textured) with white RAL 9010 epoxy powders.

**Included: fixing springs kit in galvanised steel sheet.**

**Comfort dark optics:** symmetrical 65° in anti-glare metallized polycarbonate for improved visual comfort.

**Compliant with standard:** EN60598-1, RG0 no photobiological risk for the purposes mentioned in standard EN62471.

**Led:** Lumileds SMD CR190 minimum luminous flux maintenance L80B20>50.000h.

**Multipower driver:** Included > 50,000 h Power factor ≥0.95, with accessible dip switch to be able to decrease the W and consequently the Lm.

**On request:** for quantity, the dedicated setting of the Driver current and consequently the power of W and Lm is carried out.

220 240V	50/60 Hz	IK07	IP40	CRI 90	+40 C -20	850°	CE				DRIVER INCLUDED MULTIPOWER	RG0
RETAIL	MARKET	SCHOOL 1+1=2 ABC	HOTEL	HOSPITAL	OFFICE	GYM	TOILET	EMER	Per lampade cablate in emergenza (aggiungere /EM dopo il codice) sovrapprezzo del 40%. Emergenza non possibile per versioni in linea continua. For wired emergency lights (add /EM after the code) 40% extra charge. Emergency not possible for versions in continuous line.			

### Infinity S-C

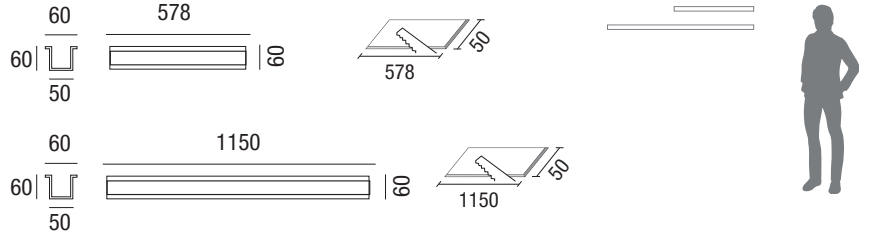

	colour	W max	Vac	lm output	lm/W	K	↓ [mm]	Kg	S+L
	B	16	220-240	2080	130	3000	578	2.00	653KRE
	B	16	220-240	2080	130	4000	578	2.00	654KRE
	<b>DALI 2 PUSH</b> B	16	220-240	2080	130	3000	578	2.00	653KDARE
	<b>DALI 2 PUSH</b> B	16	220-240	2080	130	4000	578	2.00	654KDARE
	B	30	220-240	3900	130	3000	1150	2.00	1133KRE
	B	30	220-240	3900	130	4000	1150	2.00	1134KRE
	<b>DALI 2 PUSH</b> B	30	220-240	3900	130	3000	1150	2.00	1133KDARE
	<b>DALI 2 PUSH</b> B	30	220-240	3900	130	4000	1150	2.00	1134KDARE

### Ottica diffondente 65° 65° Diffusing optics

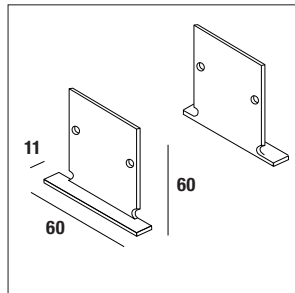
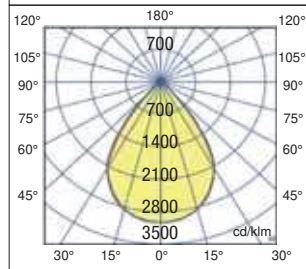

**Cod. INFYENDCAPS**  
**Testate terminali (2pcs)**  
 Coppia di testate in policarbonato bianco con fissaggio a pressione.  
**End caps (2pcs)**  
 Pair of white polycarbonate heads with pressure fixing.



### Accessori non inclusi - Not included accessories



LED driver multipower   
**RN8167**  
 max 700mA - 1135 mm  
 max 350mA- 605 mm

**RN8166**  
 max 700mA (DALI2 PUSH) - 1200 mm  
 max 350mA (DALI2 PUSH) - 605 mm

## Creta R

A RICHIESTA  
ON DEMAND

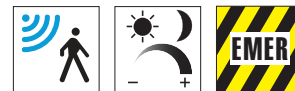

Apparecchio a LED **UGR<19** per un elevato confort visivo con un bassissimo indice di abbagliamento, in sostituzione retrofit di lampade fluorescenti installate su controsoffitti a doghe o su cartongesso. Ideale laddove è richiesta un'illuminazione con livelli di abbagliamento minimi come uffici ed Enti pubblici. Il bassissimo consumo energetico e le contenute temperature garantiscono una lunga durata al prodotto. L'utilizzo della tecnologia LED garantisce una resa luminosa elevata in relazione al consumo di energia, annullando completamente i costi di manutenzione.

**Installazione:** retrofit su doghe in metallo o cartongesso, con elementi di giunzione per linee continue e accessori a richiesta, per angoli a "L" "X" e "T".

**Corpo:** in alluminio verniciato bianco RAL 9003.

**Ottica:** diffusore in policarbonato opale o prismatico UGR 20.

**Temperatura di colore:** warm white 3000K o natural white 4000K.

**Driver multipotenza** : non incluso.

Possibilità di variare la potenza (Lm) tramite DIP. Fattore di potenza  $\geq 0,95$ .

**Conforme alla norma:** EN60598-1, RGO nessun rischio fotobiologico ai fini della norma EN62471.

**Led:** SMD Mantenimento del flusso luminoso minimo al 80%: L80B20>50.000h.

*LED fixture with **UGR<19** for high visual comfort with a very low glare index, replacing retrofit of fluorescent lamps installed on strip of slats aluminum or plasterboard. Ideal where light is required with minimal glare levels such as offices and public buildings. Very low energy consumption and low temperatures guarantee a long product life. LED technology guarantees high light output in relation to energy consumption, completely eliminating maintenance costs.*

**Installation:** retrofit for fluorescent lamps on slats aluminum or plasterboard, with junction elements for continuous lines and accessories on request, for "L" "X" and "T" corners.

**Body:** in white painted aluminum RAL 9003.

**Optic:** diffuser in opal or prismatic polycarbonate UGR 20.

**Color temperature:** warm white 3000K o natural white 4000K.

**Multipower driver** : not included.

*With possibility of decreasing power (Lm) by means of DIP switch. Power factor  $\geq 0.95$ .*  
**According to standard:** EN60598-1, RGO no photobiological risk for the purposes mentioned in standard EN62471.

**Led:** SMD Maintenance of 80% minimum luminous flux: L80B20>50.000h.



**Cod. LS7270S/M (2pcs)**  
Molle per incasso NON INCLUDE  
Springs for flush mounting NOT INCLUDED

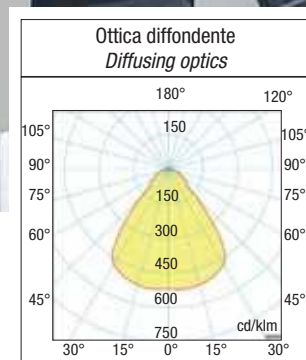

Recessed-ceiling-suspended



Senza Testate terminali / Without End caps

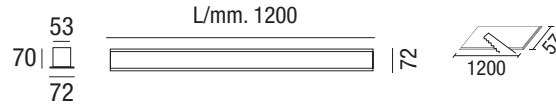

Con Testate terminali / With End caps

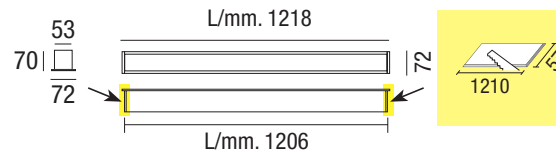

**A richiesta**  
**On request**

**220-240 Vac - 350mA - 130 lm/W**

W max	Im output	K	S+L
15	1950	3000	25889/603K
15	1950	4000	25889/604K

colour	W max	mA max	Im output	lm/W	K	L (mm)	Kg	S+L
B	30	700	3900	130	3000	1200	4.40	25889/1203K
B	30	700	3900	130	4000	1200	4.40	25889/1204K

Accessori non inclusi - Not included accessories

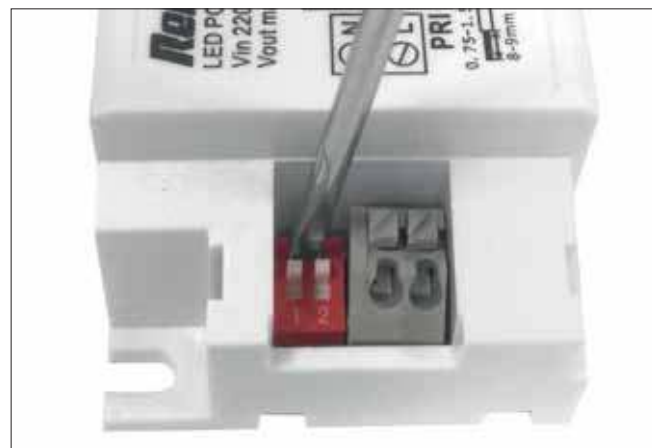

- LED driver multipower
- RN8167 - max 700mA 1200 mm
  - RN8166 - max 700mA (DALI2 PUSH) 1200 mm
  - RN8167 - max 350mA 600 mm
  - RN8166 - max 350mA (DALI2 PUSH) 600 mm

dip switch 1200 mm	Potenza Power	Lm Output
mA	Watt	Lm
350	15	1950
400	17	2210
450	19	2470
500	21	2730
550	23	2990
600	25	3250
650	27	3510
700	30	3900

Fornito di dip switch per la selezione della corrente in uscita. Il driver non è incluso nella confezione ed è normalmente settato al minimo. Se necessario è possibile aumentare la potenza e di conseguenza i lumen output senza superare i 700mA.

**Equipped with dip switch for selecting the current output.** The driver is not included inside the package and is normally set to minimum. If necessary it is possible to increase the power and consequently the lumen output without exceeding 700mA.



**Cod. 65151LED80CP3**  
L240x P59x H40  
Kit emergenza 3W - 3h/12% 180÷250 Vac  
180÷250 Vac - 3h/12% - 3W emergency kit

**Cod. RP0714CP3 - AUTOTEST**  
L195x P55x H42  
Kit emergenza 3W - 3h/12% 180÷250 Vac  
180÷250 Vac - 3h/12% - 3W emergency kit

Recessed-ceiling-suspended

**Accessori non inclusi - Not included accessories**

**Cod. LSXXXSPJT**

**Kit di giunzione scomparsa (2pcs)**

In lamiera di acciaio zincato, fissaggio con viti.

**splicing kit (2pcs)**

In galvanised steel sheet, fixing with screws.

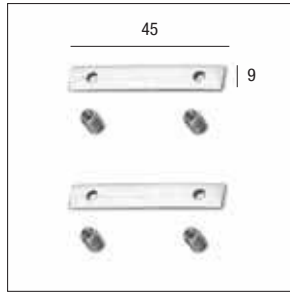

**Cod. 7270S-L**

**Kit congiunzione a L non luminoso**  
**L-shaped connection kit not bright**

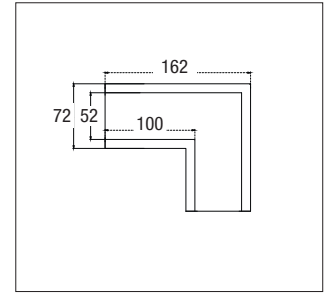

**Cod. 7270S-T**

**Kit congiunzione a T non luminoso**  
**T-shaped connection kit not bright**

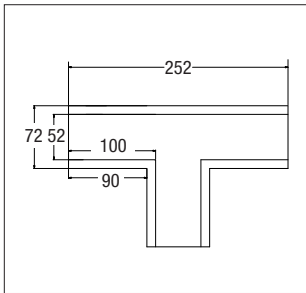

**Cod. 7270S-X**

**Kit congiunzione a X non luminoso**  
**X-shaped connection kit not bright**

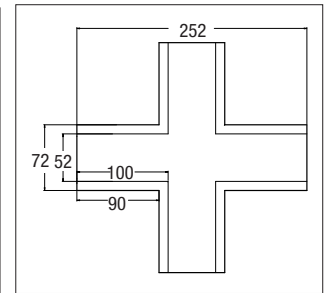

**Cod. LS7270S002**

**Testate terminali (2pcs)**  
**End caps (2pcs)**

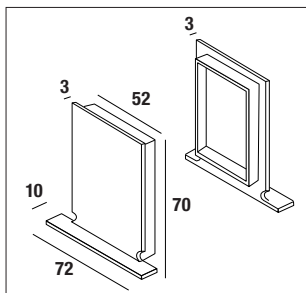

**Cod. LS7270S/M**

**Clip a molla per cartongesso e doghe in alluminio (2pcs)**  
**Spring clip for plasterboard and aluminum slats (2pcs)**

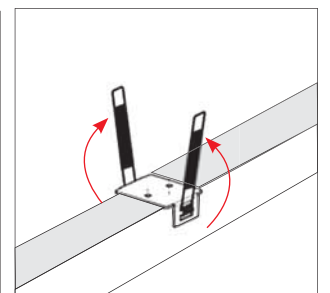
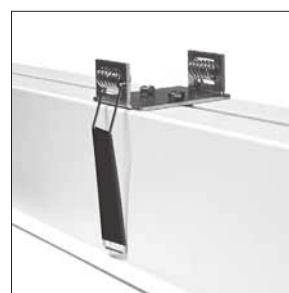

**Creta R600 - 1200**

installazione su doghe o cartongesso

on strip false ceilings or plasterboard installation

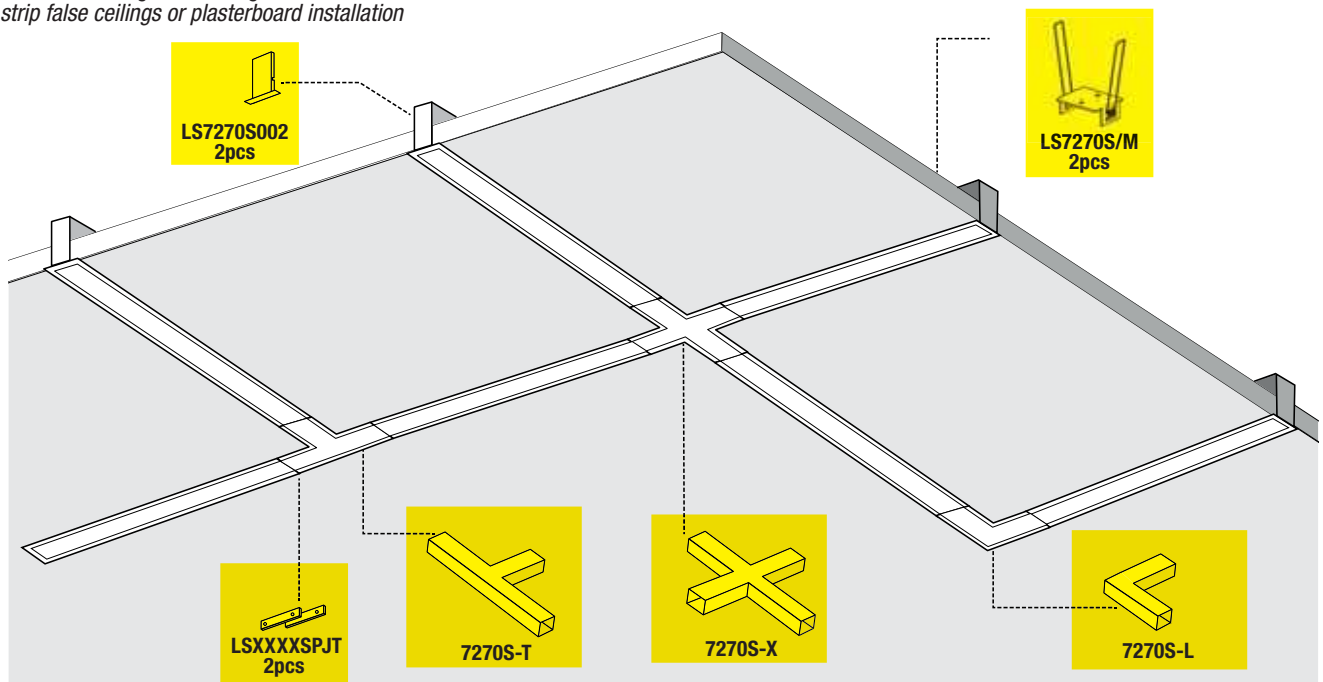

Recessed-ceiling-suspended

## Rodi R-S

A RICHIESTA  
ON DEMAND



**IK07** **IP40** **CRI 90**



Apparecchio a LED UGR<17 per un elevato confort visivo con un bassissimo indice di abbagliamento, in sostituzione retrofit di lampade fluorescenti installate su controsoffitti a doghe o su cartongesso. Driver DALI integrato.

**Installazione:** retrofit su doghe in metallo o cartongesso, sospensione con accessorio non incluso.

**Corpo:** in alluminio verniciato bianco RAL 9003.

**Ottica:** diffusore in policarbonato OPAL prismato UGR<17.

**Temperatura di colore:** warm white 3000K o natural white 4000K.

**Conforme alla norma:** EN60598-1, RG0 nessun rischio fotobiologico ai fini della norma EN62471.

**Led:** SMD Mantenimento del flusso luminoso minimo al 80%: L80B20>50.000h.

**Driver multipotenza:** Incluso > 50.000 h Fattore di potenza ≥0,95, con dip switch accessibile per poter diminuire i W e di conseguenza i Lm.

**A richiesta:** per quantità si esegue il settaggio dedicato della corrente del Driver e di conseguenza la potenza di W e Lm.

Prodotto conforme alle direttive:

**UGR<17 LED luminaire** for high visual comfort with a very low glare index, as a retrofit replacement for fluorescent lamps installed on slatted false ceilings or on plasterboard. Integrated DALI driver.

**Installation:** retrofit on metal slats or plasterboard, suspension with accessory not included.

**Body:** in RAL 9003 white painted aluminium.

**Optics:** OPAL prismatic polycarbonate diffuser UGR<17.

**Color temperature:** warm white 3000K or natural white 4000K.

**Complies with the standard:** EN60598-1, RG0 no photobiological risk for the purposes of the EN62471 standard.

**LED:** SMD Maintenance of minimum luminous flux at 80%: L80B20>50,000h.

**Multipower driver:** Included > 50,000 h Power factor ≥0.95, with accessible dip switch to be able to decrease the W and consequently the Lm.

**On request:** for quantity, the dedicated setting of the Driver current and consequently the power of W and Lm is carried out.

Product compliant with directives:

220-240V 50/60Hz

### Rodi with recessed accessories

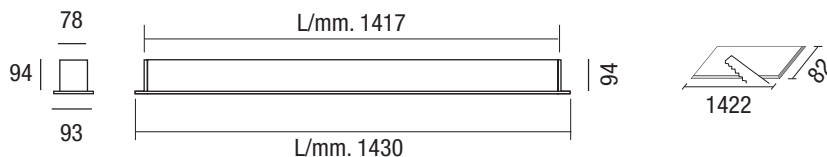

	colour	W max	Vac	lm output	lm/W	K	Kg	CELL
	B	35	220-240	3675	105	4000	5	WD354KDA

### Rodi with suspension accessories

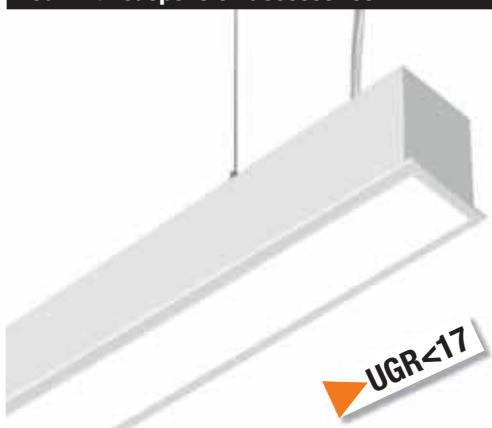

### Accessori non inclusi - Not included accessories

Cod. ENCAPSWD  
Testate terminali (2pcs)  
End caps (2pcs)



Cod. SUSPWD  
Kit sospensione max 1,5m (2pcs).  
Suspension Kit max 1,5m (2pcs).

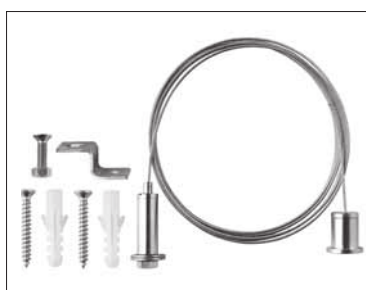

Cod. CLIPSRWD  
Clip a molla per cartongesso e doghe in alluminio (4pcs)  
Spring clip for plasterboard and aluminum slats (4pcs)

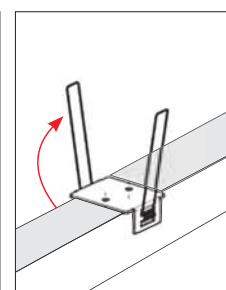
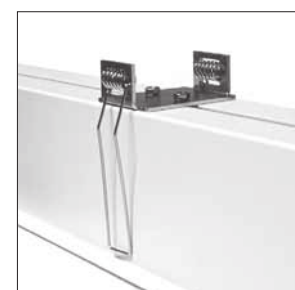

**LED Picasso - Quarantotto series**A RICHIESTA  
ON DEMAND**WIRELESS****DALI 2**

Lo speciale sistema ottico zoomabile rende LED Zoom adatto a diversi tipi di applicazione, il design minimale e snello lo rendono adatto ad abbinarsi ad ogni tipo di stile architettonico.

Disponibile in versione on /off e Dali, consente di risolvere progetti completi anche con sistemi di controllo intelligenti utilizzando un'unica tipologia di prodotto. Un buon design e una buona produzione con buoni materiali e processi garantiscono una lunga durata all'apparecchio rendendolo stabile nel tempo.

**Installazione:** su binario a 48V. (completo di adattatore)

**Corpo e verniciatura:** in alluminio pressofuso UNI 5076, verniciato con polvere termoindurente poliestere, colore nero opaco RAL 9005.

**Orientabilità:** Z=350°, Y=90°

**Viteria:** in acciaio

**Ottica:** concentrante e semi concentrante

**Temperatura di colore:** 3000K; altre temperature di colore a richiesta.

**Conforme alla norma:** EN60598-1, RG01 nessun rischio fotobiologico ai fini della norma EN62471.

**Led TWF:** mantenimento del flusso luminoso minimo al 80%: L90B10>100.000h.

**Driver:** incluso  Fattore di potenza ≥0,95.

*The special zoomable optical system makes LED Zoom suitable for different types of applications, the minimal and slim design make it suitable for combining with any type of architectural style.*

*Available in on / off and Dali versions, it allows you to solve complete projects even with intelligent control systems using a single type of product. Good design and good production with good materials and processes guarantee a long life to the appliance making it stable over time.*

**Installation:** on 48V tracks (complete with adapter).

**Body and painting:** made by UNI 5076 die-cast aluminum, coated with polyester thermoset powder, RAL Black 9005.

**Adjustability:** Z=350°, Y=90°.

**Screws:** made by steel.

**Optic:** clumping and semi-clumping.

**Color temperature:** 3000K; other color temperatures available on demand.

**According to standard:** EN60598-1, RG01 exempt from photo-biological risks in compliance with standard EN62471.

**LED TWF:** maintenance of 80% minimum luminous flux: L90B10>100.000h.

**Driver:** included  Power factor ≥0,95.



ADAPTER INCLUSO  
ADAPTER INCLUDED



## LED Picasso spot - Quarantotto



### Zoomable

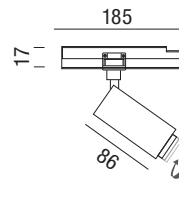
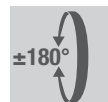
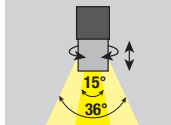

5W - 10W

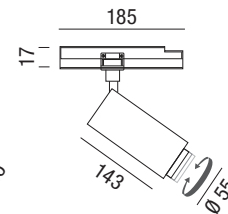

15W - 20W

	colour	W max	lm	K	△	pcs	Kg	S+L
	N	5	300	3000		001	0,25	48ZOOM3K5W
	N	5	300	3000		001	0,30	48ZOOM3K5WD
	N	10	600	3000		001	0,25	48ZOOM3K10W
	N	10	600	3000	to 15° from 36°	001	0,30	48ZOOM3K10WD
	N	15	1200	3000		001	0,39	48ZOOM3K15W
	N	15	1200	3000		001	0,44	48ZOOM3K15WD
	N	20	1600	3000		001	0,39	48ZOOM3K20W
	N	20	1600	3000		001	0,44	48ZOOM3K20WD

2700K / 4000K - A richiesta con tempi di consegna 60 giorni - On request available in 60 days



Il sistema soft zoom è ottenuto con una filettatura a passo lungo che permette di regolare l'angolo del fascio da 15 a 36 gradi mantenendo pulita la proiezione. Questo è perfetto per concentrare in un unico corpo illuminante tutta la flessibilità necessaria in spazi spesso riconfigurati. I negozi e le mostre temporanee vengono aggiornati in concomitanza con i cambiamenti nelle collezioni e nelle mostre.

The zooming smooth system by long pitch thread allows to change the beam angle from 15 to 36 degrees maintaining the projection clean. This is perfect to concentrate in one single lighting fixture all the flexibility needed in spaces that are often reconfigured. Shops and temporary exhibitions are updated to coincide with changes in collections and exhibits.

La filettatura a spirale morbida permette di regolare la apertura del fascio senza l'utilizzo di attrezzi.

The soft spiral thread allows to adjust the beam light without to use any tool.

15°

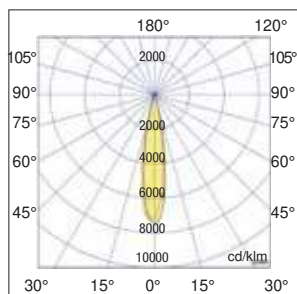

36°

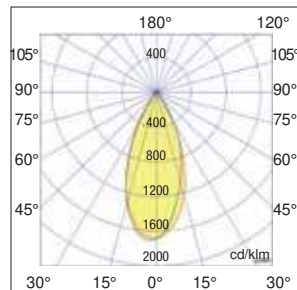

# LED Mirò





ADAPTER INCLUSO  
ADAPTER INCLUDED



## LED Mirò - Quarantotto

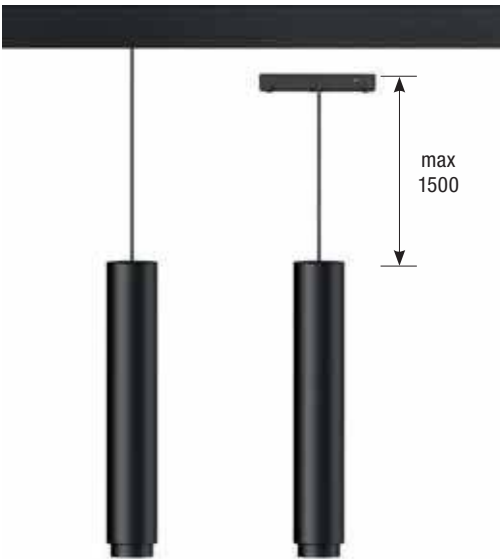

max  
1500

### Zoomable

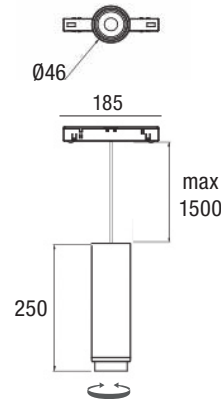
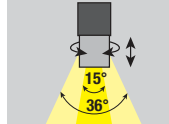

	colour	W max	lm	K		pcs	Kg	S+L
	N	5	350	3000	to 15° from 36°	001	0,41	48ZOOMS3K5W
	N	5	350	3000		001	0,46	48ZOOMS3K5WD
	N	10	700	3000	to 15° from 36°	001	0,41	48ZOOMS3K10W
	N	10	700	3000		001	0,46	48ZOOMS3K10WD
	N	10	700	4000		001	0,46	48ZOOMS4K10WD

2700K / 4000K - A richiesta con tempi di consegna 60 giorni - On request available in 60 days



Il sistema soft zoom è ottenuto con una filettatura a passo lungo che permette di regolare l'angolo del fascio da 15 a 36 gradi mantenendo pulita la proiezione. Questo è perfetto per concentrare in un unico corpo illuminante tutta la flessibilità necessaria in spazi spesso riconfigurati. I negozi e le mostre temporanee vengono aggiornati in concomitanza con i cambiamenti nelle collezioni e nelle mostre.

The zooming smooth system by long pitch thread allows to change the beam angle from 15 to 36 degrees maintaining the projection clean. This is perfect to concentrate in one single lighting fixture all the flexibility needed in spaces that are often reconfigured. Shops and temporary exhibitions are updated to coincide with changes in collections and exhibits.

15°

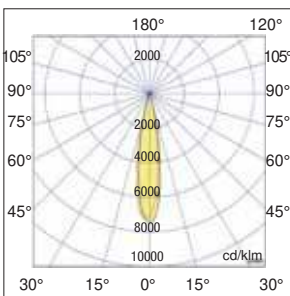

36°

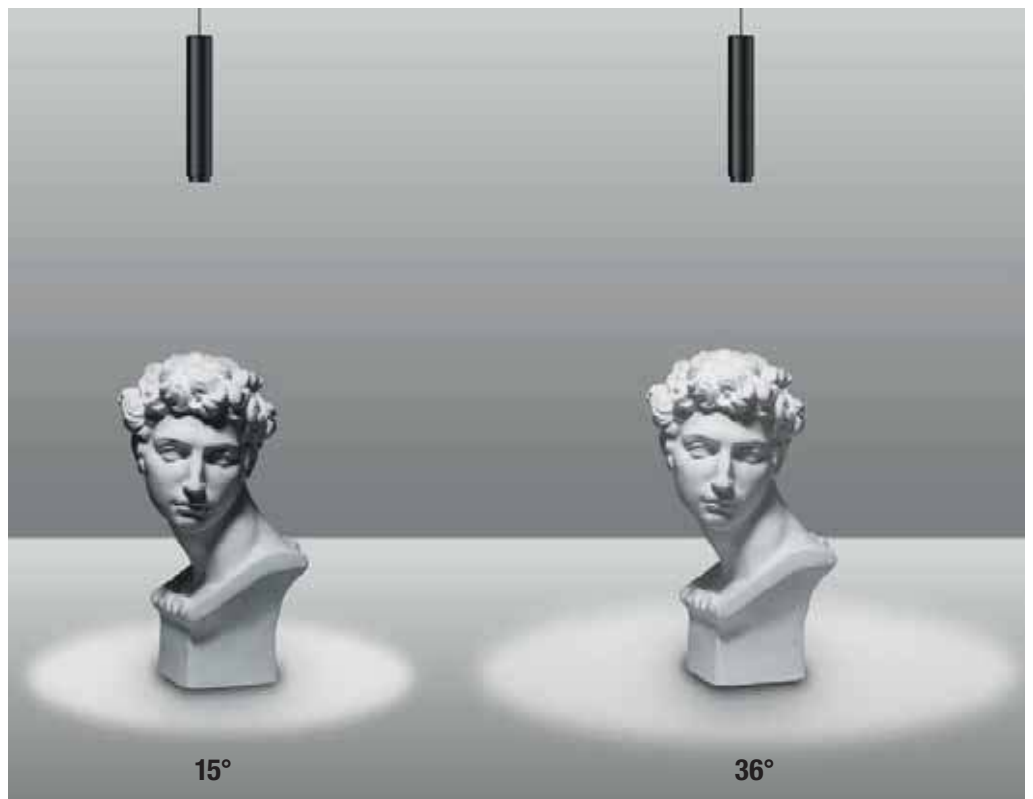
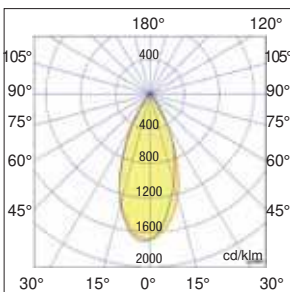

15°

36°

Track light

# LED Fontana



Track light

La dimensione del corpo e il design delle schede LED evitano punti sul diffusore. Il risultato è una perfetta linea continua di luce senza interruzioni.

*The dimension of the body and the design of the LED boards makes no dot on the diffuser. A continuous line of light for a perfect without interruption.*

48V

IK07

IP20

CR>90

+40  
C°  
-20

CE

III

48V



RG01

FLICKER FREE



SCHOOL  
1+1=2  
ABC



ADAPTER INCLUSO  
ADAPTER INCLUDED



### LED Fontana - Quarantotto

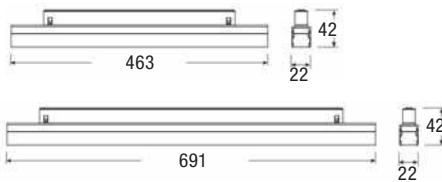

colour	W max	lm	K	Beam angle	pcs	Kg	S+L	
N	16	1100	3000	100°	001	0,31	48LINOP3K16W	
N	16	1100	4000		001	0,31	48LINOP4K16W	
<b>DALI 2</b>	N	16	1100		3000	001	0,36	48LINOP3K16WD
N	24	1500	3000		001	0,49	48LINOP3K24W	
<b>DALI 2</b>	N	24	1500		3000	001	0,54	48LINOP3K24WD

2700K / 4000K - A richiesta con tempi di consegna 60 giorni - On request available in 60 days

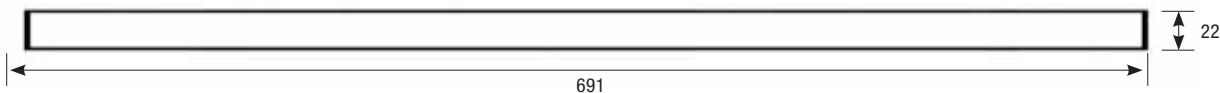
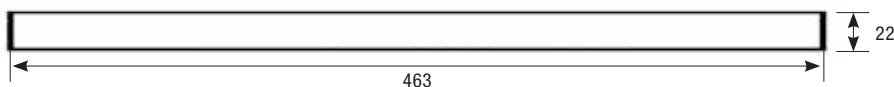

Convertitore DC/DC Driver led  
Versione ON-OFF e dimmerabile DALI  
*DC/DC converter Led driver  
ON-OFF and dimmable version DALI*

Corpo estruso per migliorare la dissipazione  
*Extruded body for heat management*

Adattatore da binario per sistema a bassa tensione 48Vdc, 4 contatti per uso ON-OFF o versione DALI  
*Track adapter for low voltage system 48V DC. 4 contacts for ON-OFF use or DALI version*

Diffusore in materiale plastico estruso ad alta efficienza  
*High efficiency plastic extruded diffuser*

Binning\* dei LED selezionato ed alto fattore di CRI.  
*Narrow LED binning\* selection and high CRI*

\* I binning è un metodo di scelta dei chip, in modo che tutti i LED di un lotto particolare abbiano lo stesso aspetto e un'emissione luminosa simile.

\* Binning is a method of choosing chips so that all LEDs in a particular batch have the same appearance and similar light output.

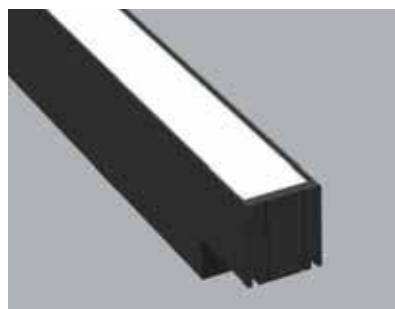

Il particolare disegno del tappo di chiusura permette di estrarlo facilmente, per rimuovere il diffusore in caso di installazione o manutenzione.

*The special design of the closing cap allows to open a little windows to remove the diffuser in case of installation and maintainance.*



Adatto per una illuminazione omogenea, per uffici, ambienti relax o spazi espositivi. L'ampio fascio luminoso consente di ridurre il numero di apparecchi ed avere una illuminazione uniforme.

*Used for geneal lighting tasks it is suitable for offices as well as relaxing rooms and open spaces. This beam angle allows to reduce the number of luminaires to have uniform illumination*

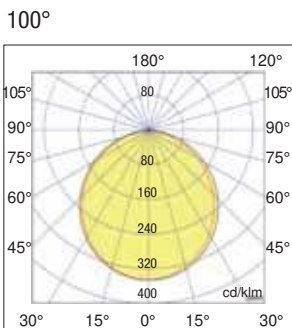

# LED Botero



48V

IK07

IP20

CR>90

+40  
°C  
-20

CE

III

48V



RG01

FLICKER FREE



SCHOOL  
1+1=2  
ABC



ADAPTER INCLUSO  
ADAPTER INCLUDED



### LED Botero - Quarantotto

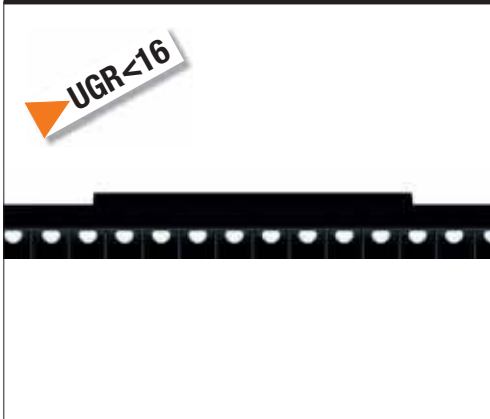

A RICHIESTA / ON REQUEST

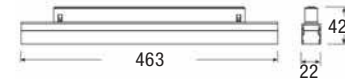

	colour	W max	lm	K	△	pcs	Kg	S+L
	N	16	1100	3000	36°	001	0,31	48LINC0B3K16
	N	16	1100	3000		001	0,36	48LINC0B3K16D
	N	24	1500	3000		001	0,49	48LINC0B3K24
	N	24	1500	3000		001	0,54	48LINC0B3K24D

2700K / 4000K - A richiesta con tempi di consegna 60 giorni - On request available in 60 days



A RICHIESTA  
ON REQUEST



Convertitore DC/DC Driver led  
Versione ON-OFF e dimmerabile DALI  
DC/DC converter Led driver  
ON-OFF and dimmable version DALI

Corpo estruso per migliorare la dissipazione  
Extruded body  
for heat management

Adattatore da binario per sistema a bassa tensione 48Vdc, 4 contatti per uso ON-OFF o versione DALI  
Track adapter for low voltage system 48V DC.  
4 contacts for ON-OFF use or DALI version

Ottica con lenti in polimero  
angolo del fascio medio, a 36°.  
Optical polymer lens  
medium beam angle, 36°.

Riflettore secondario in plastica  
per una maggior riduzione  
dell'abbagliamento  
Plastic secondary reflector  
for glare reduction

Binning\* dei LED selezionato ed alto fattore di CRI.  
Narrow LED binning\* selection and high CRI

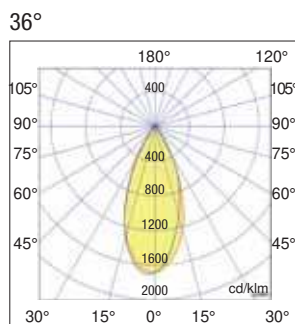

Ampliamente usato per molte applicazioni il fascio medio è il giusto compromesso per avere un alto livello di luce in negozi, ristoranti e casa senza disperdere la luce.  
Widely used for many application and tasks.it is a compromise to have high level of light in shops, restaurants and home.

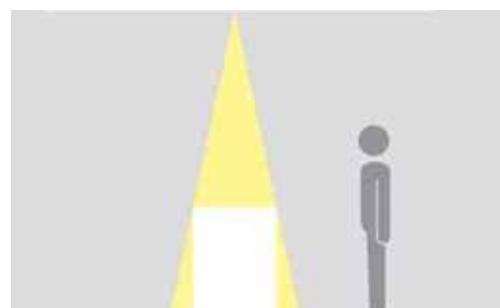

# Gilbert & George - Rotella - Burri



## LED Gilbert & George - Quarantotto serie

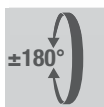
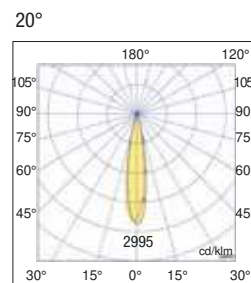
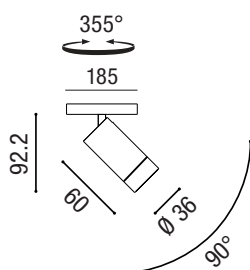

	colour	W max	lm	K		pcs	Kg	S+L
	N	5	300	3000		001	0,25	48GG3K5W
	N	5	300	4000	20°	001	0,25	48GG4K5W
	N	5	300	3000		001	0,30	48GG3K5WD

2700K / 4000K - A richiesta con tempi di consegna 60 giorni - *On request available in 60 days*

## LED Rotella - Quarantotto serie

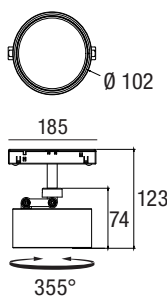

Possibili inclinazioni  
possible tilts

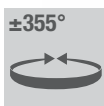
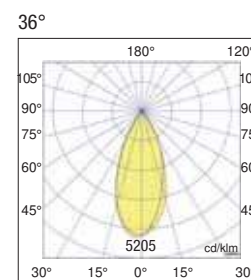
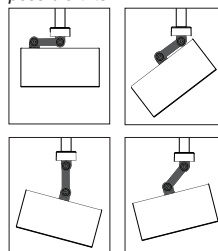

	colour	W max	lm	K		pcs	Kg	S+L
	N	18	2160	3000		001	0,25	48R03K18W
	N	18	2160	3000	36°	001	0,30	48R03K18WD

2700K / 4000K - A richiesta con tempi di consegna 60 giorni - *On request available in 60 days*

48V

IK07

IP20

CR>90

+40  
°C  
-20

CE



48V



RG01

FLICKER FREE



SCHOOL  
1+1=2  
ABC



ADAPTER INCLUSO  
ADAPTER INCLUDED



### LED Burri Glass - Quarantotto serie

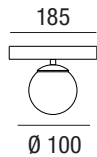

colour	W max	lm	K		pcs	Kg	S+L
B	8	390	3000	flood lights	001	0,25	48BU3K8W
<b>DALI 2</b> B	8	390	3000		001	0,30	48BU3K8WD

Sfera in Vetro  
Glass ball

2700K / 4000K - A richiesta con tempi di consegna 60 giorni - On request available in 60 days

### LED Burri Glass suspension - Quarantotto serie

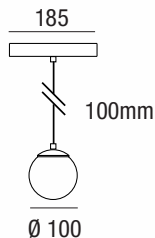

colour	W max	lm	K		pcs	Kg	S+L
B	8	390	3000	flood lights	001	0,25	48BUSU3K8W
<b>DALI 2</b> B	8	390	3000		001	0,30	48BUSU3K8WD

2700K / 4000K - A richiesta con tempi di consegna 60 giorni - On request available in 60 days

Diffondente - Flood lights

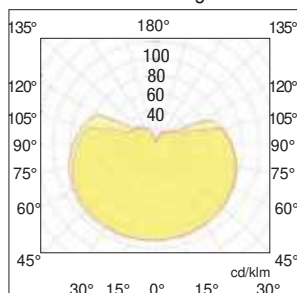

Sfera in Vetro  
Glass ball



Track light

## Binari 48V S-C-R - 48V tracks S-C-R

È un sistema completo a bassa tensione che propone binari per diversi utilizzi, per soddisfare tutte le esigenze tecniche e di design per creare linee e angoli. Lo scopo principale di questo sistema è quello di creare una soluzione decorativa e tecnica per creare linee di binario installate su superficie, a sospensione o ad incasso. Gli apparecchi vengono fissati nel binario tramite l'adattatore con un sistema meccanico.

Il binario monta 4 conduttori per consentire il corretto funzionamento sia della versione ON-OFF che di quella dimmerabile DALI. La gamma comprende diverse tipologie di adattatori, testate e connessioni per lo sviluppo di progetti di illuminazione complessi, tutti compatibili anche con il sistema.

*It is a complete low voltage system that proposes tracks for different uses, to meet all the technical and design needs to create lines and angles, the main purpose of this system is to create a decorative and technical solution to create installed track lines surface mounted, suspended or recessed. The luminaires are fixed in the track via the adapter with a mechanical system.*

*The track mounts 4 conductors to allow correct operation of both the ON-OFF version and the DALI dimmable version.*

*The range includes different types of adapters, heads and connections for the development of complex lighting projects, all of which are also compatible with the system.*

### Binario 48V su superficie o sospensione 48V in surface or suspended track



### Binario 48V ad incasso senza cornice 48V recessed trimless track

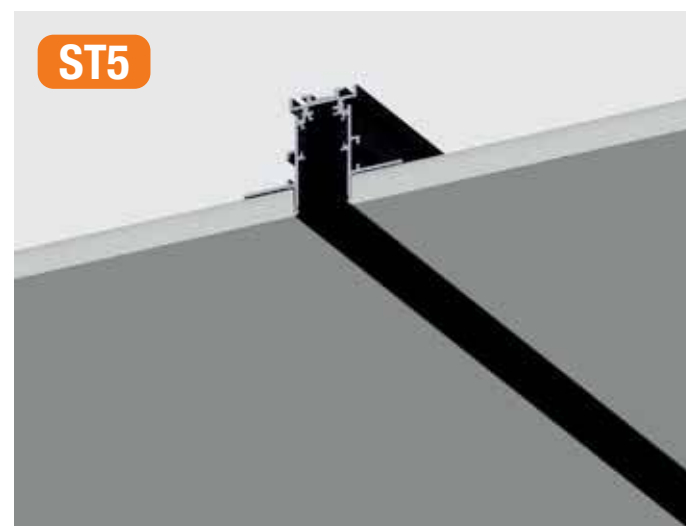

### Binario 48V a sospensione con possibilità di biemissione tramite strip LED. 48V suspension double emission track with the possibility of bi-emission via LED strip.



### Binario 48V a sospensione, biemissione. 48V suspension double emission track

Binario con doppi connettori, è possibile avere la luce diretta e indiretta utilizzando un qualsiasi corpo illuminante della serie "Quarantotto Led".  
*Track with double connectors, it is possible to have direct and indirect light using any light fitting from the "Quarantotto Led" series.*

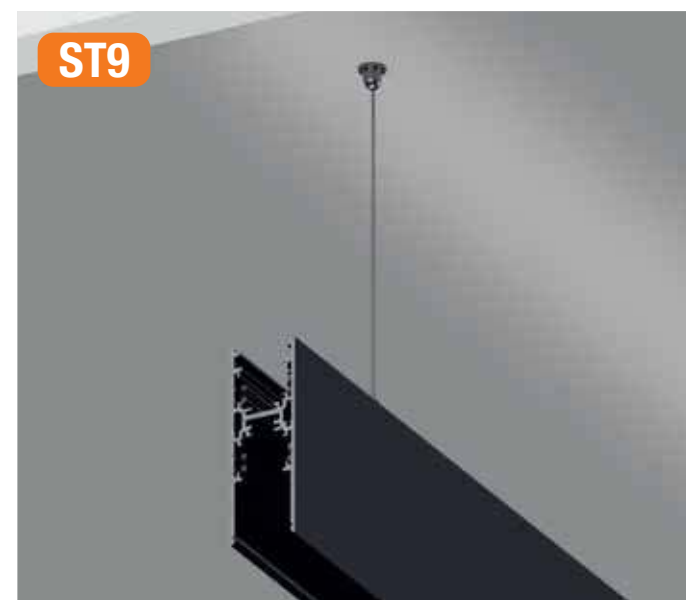

A richiesta  
*On Demand*

Alimentatore  
invisibile integrato  
a 48V, si inserisce  
nel binario con una  
leggera pressione.

*Integrated invisible  
power supply 48V  
it snaps into the rail  
with a simple push.*

Driver 48V ▶

OFF

**Clack! ON** inserimento a pressione  
*pressure insertion*

Cavo  
Cable  
3m

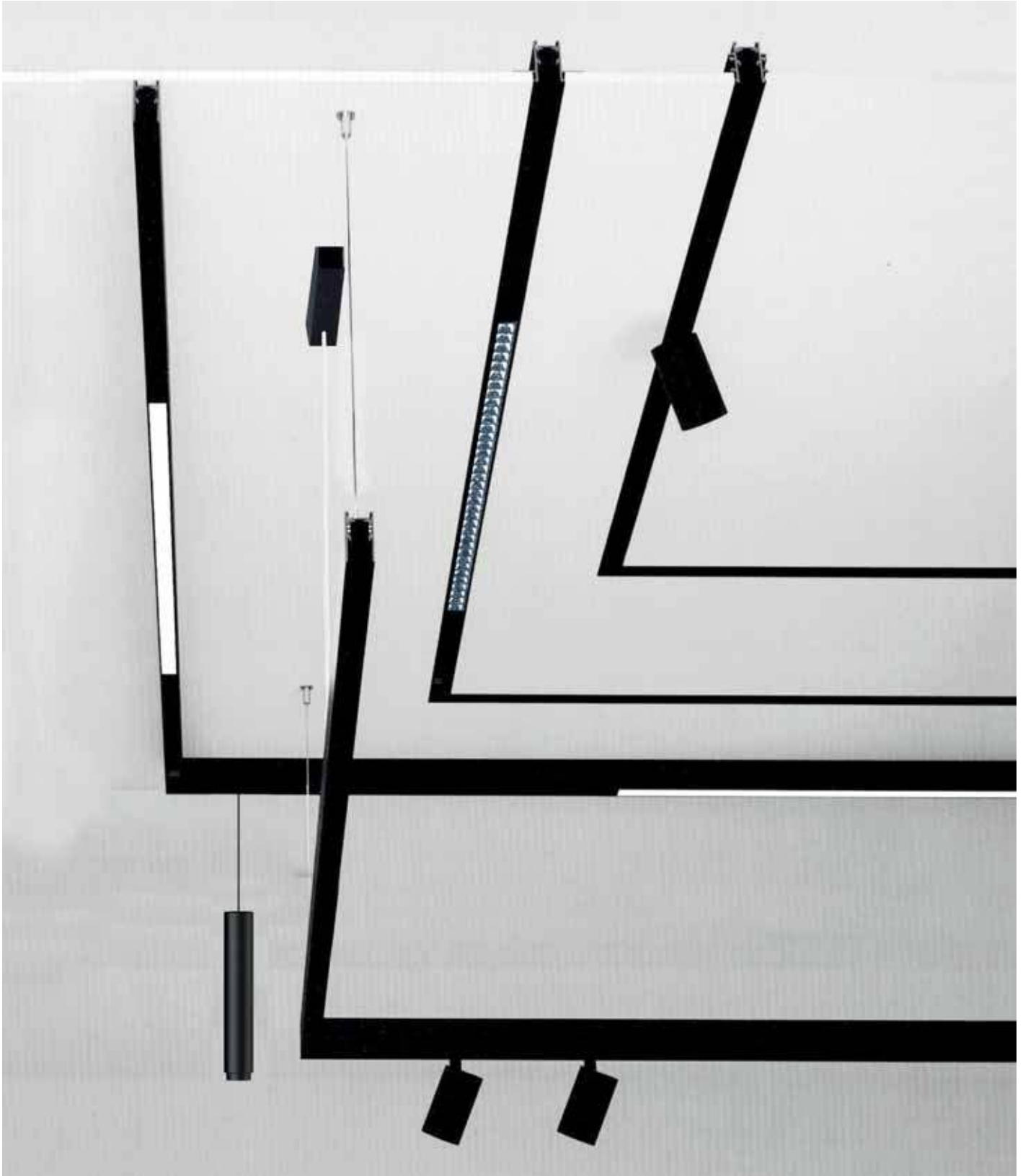

3 circuit track light

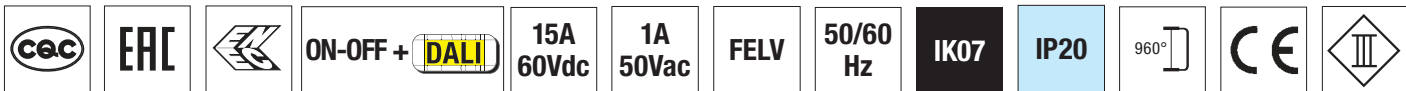

## Binario 48V a plafone o sospensione 48V ceiling or suspended track

Binario elettrificato in estruso di alluminio a bassa tensione, per installazione a plafone.  
*Low voltage extruded aluminum electrified track for ceiling installation.*

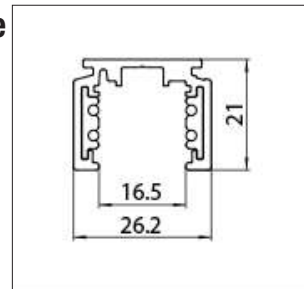

Colour	A	mm	pcs	Kg	Code
N	15	1000	001	1,71	R-1/B-ST1
N	15	2000	001	2,56	R-2/B-ST1
N	15	3000	001	3,40	R-3/B-ST1

### Accessorio non incluso - Accessories not included

#### Driver remoto a 48V. - 48V Remote Driver



Alimentatore indipendente IP20 per uso interno.  
Fornito di coprimorsetto e serracavo.  
- Morsetti di entrata e uscita contrapposti  
- Ripple di tensione:  $\pm 5\%$   
- Protezione: circuito aperto/Cortocircuito/Sovraccarico  
- Protetto in classe II contro le scosse elettriche per contatti diretti e indiretti  
- Temperatura ambiente:  $-20...45^{\circ}\text{C}$   
- Certificati: ENEC / CCC / SAA / CB CE  
- Applicazioni: striscia LED DC  
- Tensione nominale: 220-240V - 50/60Hz

*IP20 independent power supply for indoor use.  
Supplied with terminal cover and cable clamp.  
- Opposite input and output terminals  
- Voltage ripple:  $\pm 5\%$   
- Protection: Open Circuit / Short Circuit / Overload  
- Protected in class II against electric shocks for direct and indirect contacts.  
- Ambient temperature:  $-20...45^{\circ}\text{C}$   
- Certificates: ENEC / CCC / SAA / CB CE  
- Applications: DC LED strip  
- Rated voltage: 220-240V - 50/60Hz*



Codice Code	Watt* Range	Output voltage Vdc	Output current mA	Input voltage Vdc	Hz	1BA?	iC	Protocol	Power factor	LxPxH (mm)	P (mm)	H (mm)
RN9175/48/75	75	48	0-1800mA	-	50/60	15	25A 200 $\mu\text{S}$	ON-OFF	0,95 $\lambda$	180	52	30
RN9175/48/120	120	48	0-2500 mA	-	50/60	15	25A 200 $\mu\text{S}$	ON - OFF	0,95 $\lambda$	300	40	30
RN9175/48/250	250	48	0-5210 mA	-	50/60	15	25A 200 $\mu\text{S}$	ON - OFF	0,95 $\lambda$	400	40	22

\* La potenza del Driver deve essere il 20% in più rispetto a quella assorbita dal numero totale degli apparecchi.

\* Driver's power must be 20% more respect the number of devices.

Codice - Code	Descrizione - Description	LxPxH (mm)	P (mm)	H (mm)
RN9175/48/OPT	Optoisolatore, utilizzato per convertire un segnale BUS DATA SELV <i>Optoinsulate, used to convert a BUS DATA signal to a BUS DATA SELV signal</i>	170	42	28

#### Alimentatore invisibile integrato a 48V - Integrated invisible power supply 48V



- Cavo 3m (4 conduttori).  
- 2 Cavi per DALI.  
- Ripple di corrente:  $\pm 5\%$ .  
- Short time:  $<0,5\text{s} / 277\text{Vac}$ .  
- Tc:  $-40-85^{\circ}\text{C}$ .  
- Applicazioni: binario 48V.  
- Colore: Nero.

*- Cable 3m (4 conductors).  
- 2 Cables for DALI.  
- Current ripple:  $\pm 5\%$   
- Short time:  $<0,5\text{s} / 277\text{Vac}$   
- Tc:  $-40-85^{\circ}\text{C}$   
- Applications: Track light 48V  
- Colour: Black*

Codice Code	Watt Range	Output voltage Vdc	Output current A	Input voltage Vdc	Hz	1BA?	iC	Protocol	Power factor	L (mm)	P (mm)	H (mm)
RLV100W48VT3M	100	48	0-2,5	220-240	50/60	15	25A 200 $\mu\text{S}$	ON-OFF	0,95 $\lambda$	290	15	18
RLV250W48VT3M	250	48	0-2,5	220-240	50/60	15	25A 200 $\mu\text{S}$	ON - OFF	0,95 $\lambda$	258	15	44

**ACCESSORI CONNESSIONI BINARIO A PLAFONE E SOSPENSIONE**  
**CONNECTION ACCESSORIES CEILING AND SUSPENSION TRACK**



**Testata ridotta**  
*Short end feed*

Colour	pcs	Kg	Code
<b>N</b>	010	0,026	9501-S/B-E



**Giunto flessibile**  
*Adjustable corner*

Colour	pcs	Kg	Code
<b>N</b>	001	0,026	9518-S/B-E



**Giunto passante**  
*Joining connector*

Colour	pcs	Kg	Code
<b>N</b>	001	0,026	9503-S/B-E

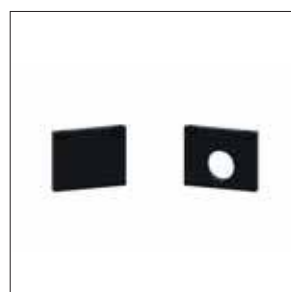

**Tappo di chiusura in plastica;**  
**...-F: con foro per cavo.**  
*Plastic sheet end cap;*  
**...-F: with hole for cable**

Colour	pcs	Kg	Code
<b>N</b>	001	0,026	9504/ST1-PB
<b>N</b>	001	0,026	9504/ST1-PB-F



**Giunto a L**  
*L joint*

Colour	pcs	Kg	Code
<b>N</b>	001	0,026	9511/B-E



**Cover di chiusura estetica 3m**  
**3m aesthetic track cover**

Colour	pcs	Kg	Code
<b>N</b>	001	0,026	S-9500/SE-B-3

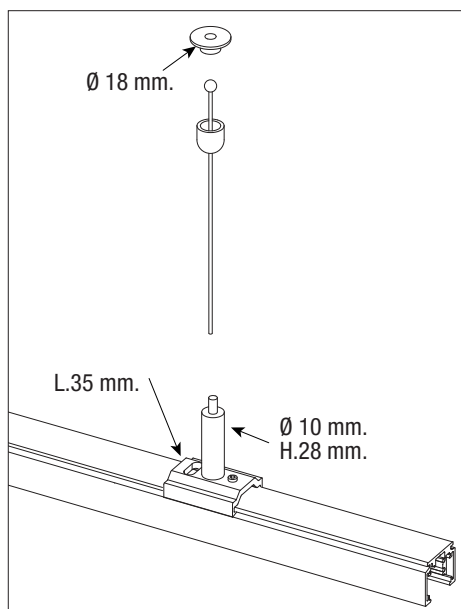

**Kit sospensione con staffa corta e tenditore automatico, cavo 3m in acciaio Ø 1,5 mm.**  
**Suspension kit with short bracket and automatic gripper, 3m cable in steel Ø 1.5 mm.**

Colour	pcs	Code
<b>C</b>	001	KITST1/1

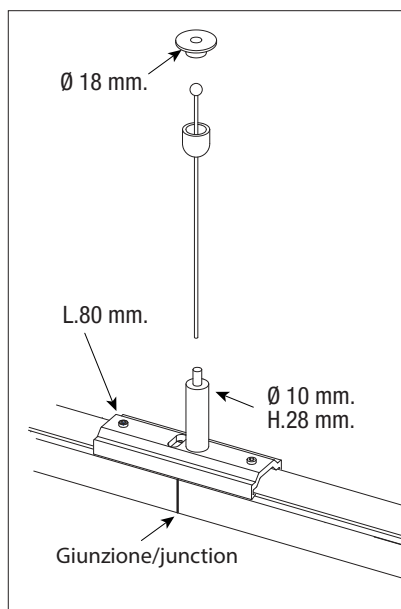

**Kit sospensione con staffa lunga e tenditore automatico per giunzione fila continua, cavo 3m in acciaio Ø 1,5 mm.**  
**Suspension kit with long bracket and automatic gripper for continuous row junction, 3m cable in steel Ø 1.5 mm.**

Colour	pcs	Code
<b>C</b>	001	KITST1/2

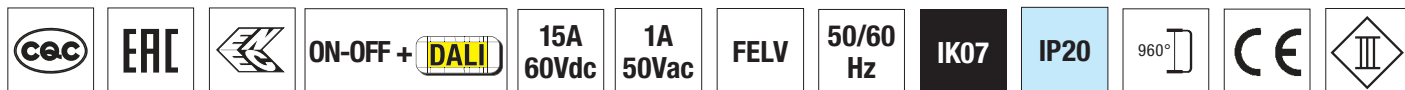

**Binario 48V a sospensione con possibilità di biemissione tramite strip LED.**

**48V suspension double emission track with the possibility of bi-emission via LED strip.**

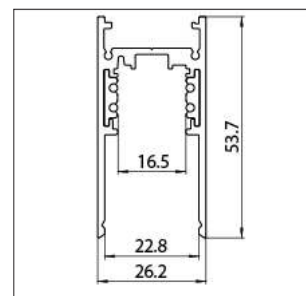

Binario elettrificato in estruso di alluminio a bassa tensione, per installazione a sospensione con possibilità di luce indiretta con accensione separata.

Low voltage extruded aluminum electrified track for suspended installation indirect light with separate switch available on request.

Colour	A	mm	pcs	Kg	Code
N	15	1000	001	1,71	R-1/B-ST2
N	15	2000	001	2,56	R-2/B-ST2
N	15	3000	001	3,40	R-3/B-ST2

### Accessori non inclusi - Accessories not included

#### Driver remoto a 48V. - 48V Remote Driver



- Alimentatore indipendente IP20 per uso interno.  
Fornito di coprimorsetto e serracavo.
- Morsetti di entrata e uscita contrapposti
  - Ripple di tensione:  $\pm 5\%$
  - Protezione: circuito aperto/Cortocircuito/Sovraccarico
  - Protetto in classe II contro le scosse elettriche per contatti diretti e indiretti
  - Temperatura ambiente:  $-20...45^{\circ}\text{C}$
  - Certificati: ENEC / CCC / SAA / CB CE
  - Applicazioni: striscia LED DC
  - Tensione nominale: 220-240V - 50/60Hz

- IP20 independent power supply for indoor use.  
Supplied with terminal cover and cable clamp.
- Opposite input and output terminals
  - Voltage ripple:  $\pm 5\%$
  - Protection: Open Circuit / Short Circuit / Overload
  - Protected in class II against electric shocks for direct and indirect contacts.
  - Ambient temperature:  $-20...45^{\circ}\text{C}$
  - Certificates: ENEC / CCC / SAA / CB CE
  - Applications: DC LED strip
  - Rated voltage: 220-240V - 50/60Hz



Codice Code	Watt* Range	Output voltage Vdc	Output current mA	Input voltage Vdc	Hz	15A?	1C	Protocol	Power factor	LxPxH (mm)	P (mm)	H (mm)
RN9175/48/75	75	48	0-1800mA	-	50/60	15	25A 200 $\mu$ S	ON-OFF	0,95 $\lambda$	180	52	30
RN9175/48/120	120	48	0-2500 mA	-	50/60	15	25A 200 $\mu$ S	ON - OFF	0,95 $\lambda$	300	40	30
RN9175/48/250	250	48	0-5210 mA	-	50/60	15	25A 200 $\mu$ S	ON - OFF	0,95 $\lambda$	400	40	22

\* La potenza del Driver deve essere il 20% in più rispetto a quella assorbita dal numero totale degli apparecchi.

\* Driver's power must be 20% more respect the number of devices.

Codice - Code	Descrizione - Description	LxPxH (mm)	P (mm)	H (mm)
RN9175/48/OPT	Optoisolatore, utilizzato per convertire un segnale BUS DATA SELV Optoinsulate, used to convert a BUS DATA signal to a BUS DATA SELV signal	170	42	28

Componente per luce indiretta - *Indirect light component*



colour	W metro	 Led/mt *	Pitch	K	Lm/m	Efficiency	Kg	Width mm.	S+L
T	19,2	120	33.33	3000	1632	100	0,36	10	30904/48
T	19,2	120	33.33	4000	1728	100	0,36	10	90.012/010/48

\*Anzahl der LEDs pro laufendem Meter - \*Quantité de LED par mètre linéaire

accessori inclusi - included accessories

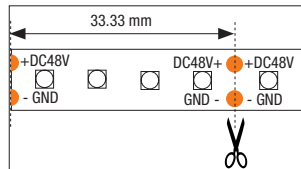

Effettuare il taglio in corrispondenza del simbolo della forbice e la linea tratteggiata.

Make the cut in correspondence of the scissor symbol and dotted line.

Per la doppia accensione richiedere la versione custom al reparto project  
For dual ignition, request the custom version from the project department

[projects@relcogroup.com](mailto:projects@relcogroup.com)





**Testata ridotta**  
*Short end feed*

Colour	pcs	Kg	Code
<b>N</b>	010	0,026	9501-S/B-E



**Clip in acciaio verniciato per montaggio a plafone.**  
*Clamp in painted steel for ceiling mounting*

Colour	pcs	Kg	Code
<b>N</b>	010	0,026	S-9500/115-B



**Giunto passante**  
*Joining connector*

Colour	pcs	Kg	Code
<b>N</b>	001	0,026	9503-S/B-E

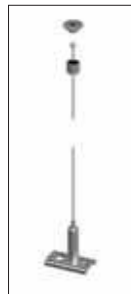

**Kit completi per il fissaggio a sospensione con staffa corta.**  
*Complete suspension kit with short bracket.*

- rosone metallico sferico con foro
- filo in acciaio Ø 1.5mm:
- L=3000/5000mm con estremità sferica
- staffa con tenditore automatico
- round head ceiling attachment
- steel cable Ø 1,5mm:
- L=3000/5000mm with spherical end
- bracket with automatic gripper

Colour	m	Kg	Code
<b>G</b>	3m	0,026	9500-KIT1-3
<b>G</b>	5m	0,026	9500-KIT1-5



**Giunto a L**  
*L joint*

Colour	pcs	Kg	Code
<b>N</b>	001	0,026	9511/B-E



**Komplette Bausätze für die Aufhängung mit langem Bügel.**  
*Kits complets pour la fixation suspendue avec étrier long.*

- rosone metallico sferico con foro
- filo in acciaio Ø 1.5mm:
- L=3000/5000mm con estremità sferica
- staffa con tenditore automatico
- round head ceiling attachment
- steel cable Ø 1,5mm:
- L=3000/5000mm with spherical end
- bracket with automatic gripper

Colour	m	Kg	Code
<b>G</b>	3m	0,026	9500-KIT2-3
<b>G</b>	5m	0,026	9500-KIT2-5



**Giunto flessibile**  
*Adjustable corner*

Colour	pcs	Kg	Code
<b>N</b>	001	0,026	9518-S/B-E



**Cover di chiusura estetica 3m**  
*3m aesthetic track cover*

Colour	pcs	Kg	Code
<b>N</b>	001	0,026	S-9500/LE-B-3



**Giunto meccanico a L in plastica**  
*Plastic mechanical L joint*

Colour	pcs	Kg	Code
<b>N</b>	001	0,026	S9511/B-P-ST2



**Tappo di chiusura in plastica;**  
**...-F: con foro per cavo.**  
*Plastic sheet end cap;*  
*...-F: with hole for cable*

Colour	pcs	Kg	Code
<b>N</b>	001	0,026	9504/ST2-PB
<b>N</b>	001	0,026	9504/ST2-PB-F

3 circuit Track light



3 circuit track light

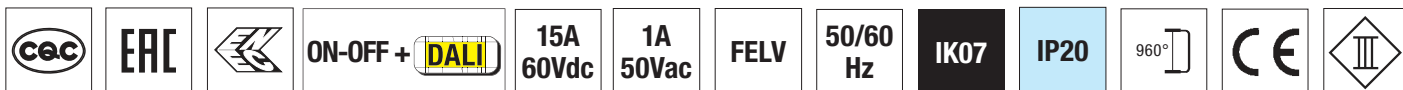

### Binario 48V ad incasso senza cornice 48V recessed trimless track

Binario elettrificato in estruso di alluminio a bassa tensione, per installazione da incasso su cartongesso da montare prima della posa.

*Low voltage electrified extruded aluminum track for recessed installation*

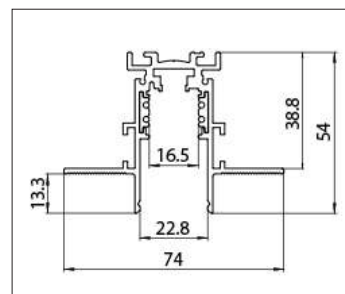

Colour	A	mm	pcs	Kg	Code
N	15	1000	001	1,71	R-1/B-ST5
N	15	2000	001	2,56	R-2/B-ST5
N	15	3000	001	3,40	R-3/B-ST5

#### Accessorio non incluso - Accessories not included

### Driver remoto a 48V. - 48V Remote Driver



Alimentatore indipendente IP20 per uso interno. Fornito di coprimorsetto e serracavo.  
 - Morsetti di entrata e uscita contrapposti  
 - Ripple di tensione:  $\pm 5\%$   
 - Protezione: circuito aperto/Cortocircuito/Sovraccarico  
 - Protetto in classe II contro le scosse elettriche per contatti diretti e indiretti  
 - Temperatura ambiente:  $-20...45^{\circ}\text{C}$   
 - Certificati: ENEC / CCC / SAA / CB CE  
 - Applicazioni: striscia LED DC  
 - Tensione nominale: 220-240V - 50/60Hz

*IP20 independent power supply for indoor use. Supplied with terminal cover and cable clamp.*  
 - Opposite input and output terminals  
 - Voltage ripple:  $\pm 5\%$   
 - Protection: Open Circuit / Short Circuit / Overload  
 - Protected in class II against electric shocks for direct and indirect contacts.  
 - Ambient temperature:  $-20...45^{\circ}\text{C}$   
 - Certificates: ENEC / CCC / SAA / CB CE  
 - Applications: DC LED strip  
 - Rated voltage: 220-240V - 50/60Hz



Codice Code	Watt* Range	Output voltage Vdc	Output current mA	Input voltage Vdc	Hz	IBA	ic	Protocol	Power factor	LxPxH (mm)	P (mm)	H (mm)
RN9175/48/75	75	48	0-1800mA	-	50/60	15	25A 200 $\mu\text{S}$	ON-OFF	0,95 $\lambda$	180	52	30
RN9175/48/120	120	48	0-2500 mA	-	50/60	15	25A 200 $\mu\text{S}$	ON - OFF	0,95 $\lambda$	300	40	30
RN9175/48/250	250	48	0-5210 mA	-	50/60	15	25A 200 $\mu\text{S}$	ON - OFF	0,95 $\lambda$	400	40	22

\* La potenza del Driver deve essere il 20% in più rispetto a quella assorbita dal numero totale degli apparecchi.

\* Driver's power must be 20% more respect the number of devices.

Codice - Code	Descrizione - Description	LxPxH (mm)	P (mm)	H (mm)
RN9175/48/OPT	Optoisolatore, utilizzato per convertire un segnale BUS DATA SELV Optoinsulate, used to convert a BUS DATA signal to a BUS DATA SELV signal	170	42	28

### Alimentatore invisibile integrato a 48V - Integrated invisible power supply 48V



- Cavo 3m (4 conduttori).  
 - 2 Cavi per DALI.  
 - Ripple di corrente:  $\pm 5\%$ .  
 - Short time:  $<0,5\text{s} / 277\text{Vac}$ .  
 - Tc:  $-40-85^{\circ}\text{C}$ .  
 - Applicazioni: binario 48V.  
 - Colore: Nero.

*- Cable 3m (4 conductors).  
 - 2 Cables for DALI.  
 - Current ripple:  $\pm 5\%$   
 - Short time:  $<0,5\text{s} / 277\text{Vac}$   
 - Tc:  $-40-85^{\circ}\text{C}$   
 - Applications: Track light 48V  
 - Colour: Black*

Codice Code	Watt Range	Output voltage Vdc	Output current A	Input voltage Vdc	Hz	IBA	ic	Protocol	Power factor	L (mm)	P (mm)	H (mm)
RLV100W48VT3M	100	48	0-2,5	220-240	50/60	15	25A 200 $\mu\text{S}$	ON-OFF	0,95 $\lambda$	290	15	18
RLV250W48VT3M	250	48	0-2,5	220-240	50/60	15	25A 200 $\mu\text{S}$	ON - OFF	0,95 $\lambda$	258	15	44



**Testata ridotta**  
*Short end feed*

Colour	pcs	Kg	Code
<b>N</b>	010	0,026	9501-S/B-E



**Cover angolare**  
*Angular cover*

Colour	pcs	Kg	Code
<b>N</b>	001	0,026	S-9511/B-ST5



**Giunto passante**  
*Joining connector*

Colour	pcs	Kg	Code
<b>N</b>	001	0,026	9503-S/B-E



**Cover di chiusura estetica 3m**  
*3m aesthetic track cover*

Colour	pcs	Kg	Code
<b>N</b>	001	0,026	S-9500/LE-B-3



**Giunto a L**  
*L joint*

Colour	pcs	Kg	Code
<b>N</b>	001	0,026	9511/B-E



**Tappo di chiusura in plastica;**  
*...-F: con foro per cavo.*  
**Plastic sheet end cap;**  
*...-F: with hole for cable*

Colour	pcs	Kg	Code
<b>N</b>	001	0,026	9504/ST2-PB
<b>N</b>	001	0,026	9504/ST2-PB-F



**Giunto flessibile**  
*Adjustable corner*

Colour	pcs	Kg	Code
<b>N</b>	001	0,026	9518-S/B-E



**Clips in acciaio verniciato. Tenditore**  
**M6 in acciaio zincato**  
*Clamp in painted steel. M6 threaded gripper in zinc plated steel*

Colour	pcs	Kg	Code
<b>N</b>	001	0,026	S-9000/118-B



**Giunto lineare meccanico**  
*Mechanical linear joint*

Colour	pcs	Kg	Code
<b>N</b>	001	0,026	S-9500/314-B



**Set per fissaggio a sospensione**  
**suspension sets**

- staffa per fissaggio a soffitto
- dado M6
- barra filettata M6 (L=1000mm)
- ceiling bracket
- M6 nut
- M6 threaded bar (L=1000mm)

Colour	pcs	Kg	Code
<b>N</b>	001	0,026	S-9000-P4

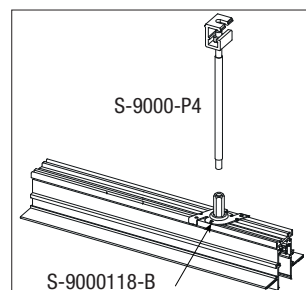
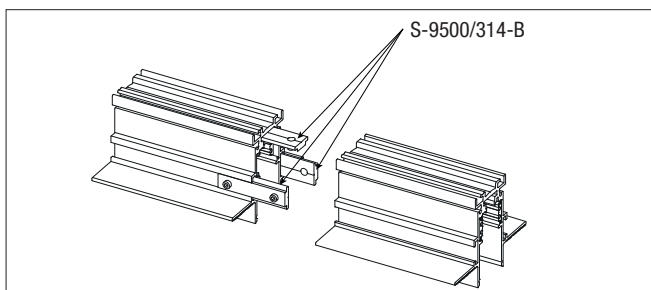

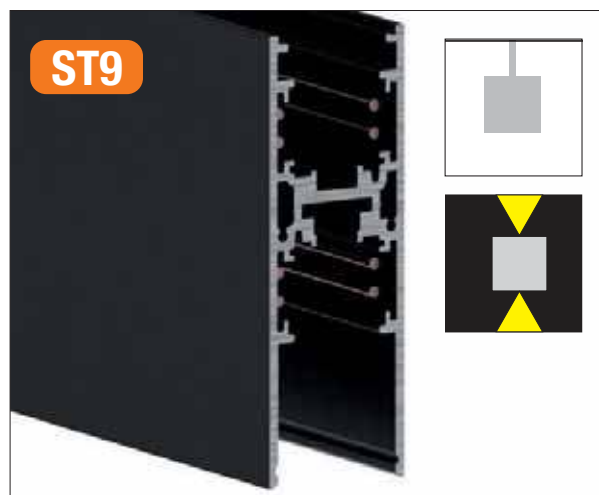
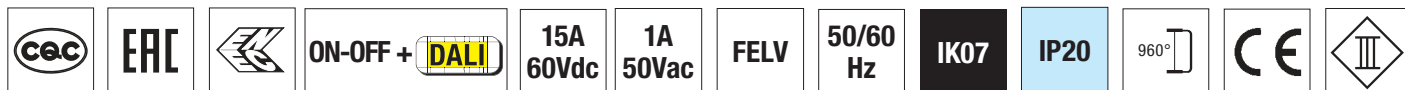

**Binario 48V a sospensione, biemissione.**  
**48V suspension double emission track**

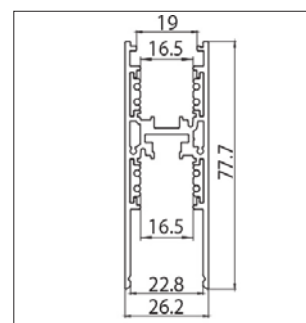

Colour	A	mm	pcs	Kg	Code
N	15	1000	001	1,71	R-1/B-ST9
N	15	2000	001	2,56	R-2/B-ST9
N	15	3000	001	3,40	R-3/B-ST9

**Accessorio non incluso - Accessories not included**

**Driver remoto a 48V. - 48V Remote Driver**



Alimentatore indipendente IP20 per uso interno.  
 Fornito di coprimorsetto e serracavo.  
 - Morsetti di entrata e uscita contrapposti  
 - Ripple di tensione:  $\pm 5\%$   
 - Protezione: circuito aperto/Cortocircuito/Sovraccarico  
 - Protetto in classe II contro le scosse elettriche per contatti diretti e indiretti  
 - Temperatura ambiente:  $-20...45^{\circ}\text{C}$   
 - Certificati: ENEC / CCC / SAA / CB CE  
 - Applicazioni: striscia LED DC  
 - Tensione nominale: 220-240V - 50/60Hz

IP20 independent power supply for indoor use.  
 Supplied with terminal cover and cable clamp.  
 - Opposite input and output terminals  
 - Voltage ripple:  $\pm 5\%$   
 - Protection: Open Circuit / Short Circuit / Overload  
 - Protected in class II against electric shocks for direct and indirect contacts.  
 - Ambient temperature:  $-20...45^{\circ}\text{C}$   
 - Certificates: ENEC / CCC / SAA / CB CE  
 - Applications: DC LED strip  
 - Rated voltage: 220-240V - 50/60Hz



Codice Code	Watt* Range	Output voltage Vdc	Output current mA	Input voltage Vdc	Hz	1BA?	iC	Protocol	Power factor	LxPxH (mm)	P (mm)	H (mm)
RN9175/48/75	75	48	0-1800mA	-	50/60	15	25A 200 $\mu\text{S}$	ON-OFF	0,95 $\lambda$	180	52	30
RN9175/48/120	120	48	0-2500 mA	-	50/60	15	25A 200 $\mu\text{S}$	ON - OFF	0,95 $\lambda$	300	40	30
RN9175/48/250	250	48	0-5210 mA	-	50/60	15	25A 200 $\mu\text{S}$	ON - OFF	0,95 $\lambda$	400	40	22

\* La potenza del Driver deve essere il 20% in più rispetto a quella assorbita dal numero totale degli apparecchi.  
 \* Driver's power must be 20% more respect the number of devices.

Codice - Code	Descrizione - Description	LxPxH (mm)	P (mm)	H (mm)
RN9175/48/OPT	Optoisolatore, utilizzato per convertire un segnale BUS DATA SELV <i>Optoinsulate, used to convert a BUS DATA signal to a BUS DATA SELV signal</i>	170	42	28

**Alimentatore invisibile integrato a 48V - Integrated invisible power supply 48V**



- Cavo 3m (4 conduttori).  
 - 2 Cavi per DALI.  
 - Ripple di corrente:  $\pm 5\%$ .  
 - Short time:  $<0,5\text{s} / 277\text{Vac}$ .  
 - Tc:  $-40-85^{\circ}\text{C}$ .  
 - Applicazioni: binario 48V.  
 - Colore: Nero.

- Cable 3m (4 conductors).  
 - 2 Cables for DALI.  
 - Current ripple:  $\pm 5\%$   
 - Short time:  $<0,5\text{s} / 277\text{Vac}$   
 - Tc:  $-40-85^{\circ}\text{C}$   
 - Applications: Track light 48V  
 - Colour: Black

Codice Code	Watt Range	Output voltage Vdc	Output current A	Input voltage Vdc	Hz	1BA?	iC	Protocol	Power factor	L (mm)	P (mm)	H (mm)
RLV100W48VT3M	100	48	0-2,5	220-240	50/60	15	25A 200 $\mu\text{S}$	ON-OFF	0,95 $\lambda$	290	15	18
RLV250W48VT3M	250	48	0-2,5	220-240	50/60	15	25A 200 $\mu\text{S}$	ON - OFF	0,95 $\lambda$	258	15	44

## Binario 48V a sospensione biemissione, possibili combinazioni *possible combinations 48V suspension double emission track*



Binario con doppi connettori, è possibile avere la luce **diretta** utilizzando un qualsiasi corpo illuminante della serie “**Quarantotto Led**”, per la luce **indiretta** utilizzare solo Led Zoom Spot.

*Track with double connectors, it is possible to have **direct light** using any lighting fixture from the “**Quarantotto Led**” series, for **indirect light** use only Zoom Spot Leds.*

Alimentatore invisibile integrato a 48V - si inserisce nel binario con una leggera pressione.  
*Integrated invisible power supply 48V - it snaps into the rail with a simple push.*



Cavo  
Cable  
3m

**Clack! ON** inserimento a pressione  
*pressure insertion*

**ACCESSORI CONNESSIONI BINARIO A SOSPENSIONE**  
**CONNECTION ACCESSORIES SUSPENSION TRACK**



**Testata ridotta**  
*Short end feed*

Colour	pcs	Kg	Code
<b>N</b>	010	0,026	9501-S/B-E



**Tappo di chiusura in plastica.**  
*Plastic sheet end cap.*

Colour	pcs	Kg	Code
<b>N</b>	001	0,026	9504-ST9-B



**Giunto passante**  
*Joining connector*

Colour	pcs	Kg	Code
<b>N</b>	001	0,026	9503-S/B-E



**Cover di chiusura estetica 3m**  
*3m aesthetic track cover*

Colour	pcs	Kg	Code
<b>N</b>	001	0,026	S-9500/LE-B-3



**Giunto a L**  
*L joint*

Colour	pcs	Kg	Code
<b>N</b>	001	0,026	9511/B-E



**Giunto meccanico a L in plastica**  
*Plastic mechanical L joint*

Colour	pcs	Kg	Code
<b>N</b>	001	0,026	S-9511-ST9-E



**Giunto flessibile**  
*Adjustable corner*

Colour	pcs	Kg	Code
<b>N</b>	001	0,026	9518-S/B-E

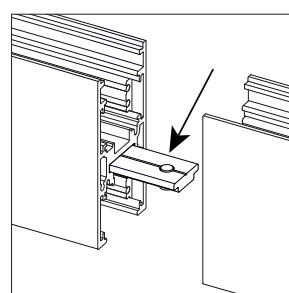

**Staffa di rinforzo per giunto passante**  
*Reinforcing bracket for joining connector*

Colour	pcs	Kg	Code
<b>N</b>	010	0,026	S-9500/314-B

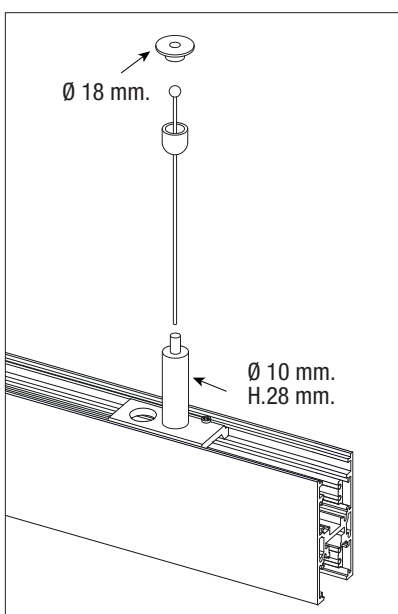

**Kit sospensione con staffa corta e tenditore automatico, cavo 3m in acciaio Ø 1,5 mm.**  
*Suspension kit with short bracket and auto-matic gripper, 3m cable in steel Ø 1.5 mm.*

Colour	pcs	Code
<b>C</b>	001	KITST9/1



Regolabile in altezza  
 Height adjustable

3 circuit Track light

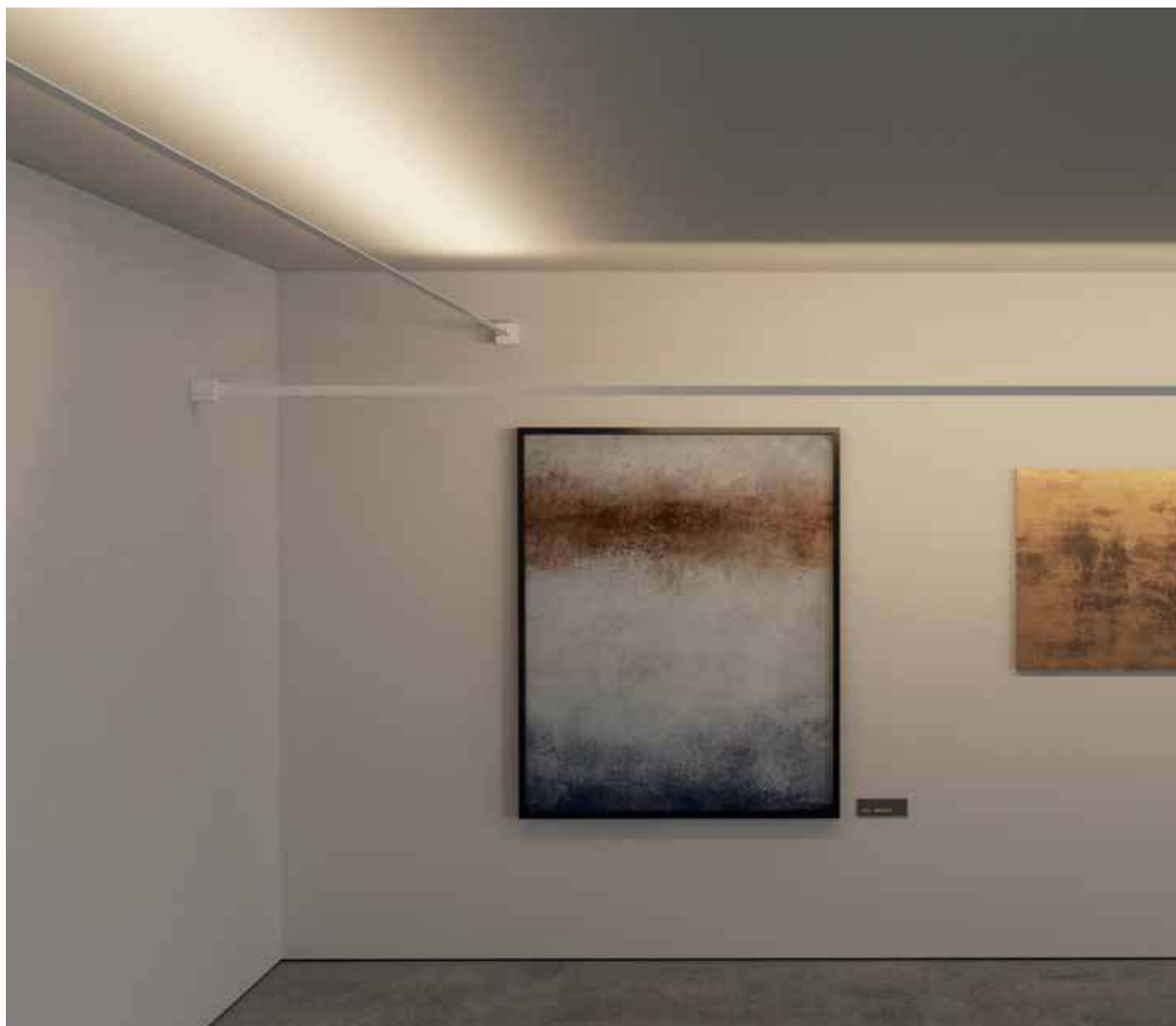

**Estensione LED**A RICHIESTA  
ON DEMAND**WIRELESS****0-10V****DALI 2****Estensione LED.**

È un novo modo di pensare la luce: grazie alla sua flessibilità è facilmente trasportabile e tagliabile su misura, può essere montato a parete, a soffitto o da parete a soffitto.

**È un sistema in bassa tensione sviluppato sia per l'illuminazione diretta che indiretta degli ambienti.**

**Installazione:** Gli attacchi, con sistema a perno interno, rendono possibile la rotazione orizzontale a 180° del cavo, possibilità di combinare strip led e faretto Mini LED. Infinite posizioni per infiniti utilizzi

**Corpo:** realizzato in materiale plastico isolante. Integra, internamente, due cavi tenditori in acciaio che permettono di realizzare tesate fino a 10m di lunghezza. Bianco RAL 9010 e nero RAL 9005.

**Conforme alla norma:** 60598-2-23

**Led:** strip led 24V Flex cob; 3000K - 4000K.

strip led 24V Flex Bianco dinamico 2700>6500K.

**Driver:** Alimentatore 24V a 60W, 120W e 200W.

**Controller:** KZQ-3 per la dimmerazione della luce.

**Led:** Spot led 48V; 3000K - 4000K.

**Driver:** Alimentatore 48V a 70W, e 150W.

**Controller:** KZQ-3 per la dimmerazione della luce.

**Estensione LED.**

*is a new way of thinking about light: thanks to its flexibility it is easily transportable and cut to size, it can be mounted on the wall, ceiling or wall-to-ceiling.*

***It is a low tension system developed for both direct and indirect lighting of environments.***

***Installation:*** The connections, with internal pin system, make it possible to rotate the cable horizontally by 180°, possibility of combining LED strips and Mini LED spotlights. Infinite positions for infinite uses

***Body:*** made of insulating plastic material. It integrates, internally, two steel tension cables that allow for the creation of stretches up to 10m in length. White RAL 9010 and black RAL 9005.

*Compliant with standard: 60598-2-23*

***Led:*** 24V Flex Cob led strip; 3000K - 4000K.

*24V Flex monochromatic led strip Tunable white 6500K.*

***Driver:*** 24V 60W, 120W and 200W.

***Controller:*** KZQ-3 controller for light dimming.

***Led:*** Spot led 48V; 3000K - 4000K.

***Driver:*** 48V power supply at 70W and 150W.

***Controller:*** KZQ-3 controller for light dimming.

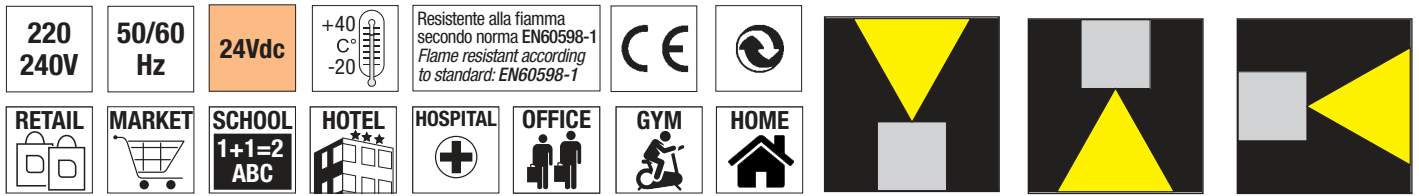

Estensione LED è indicato per l'illuminazione indiretta, diretta e l'illuminazione laterale.

*Estensione LED is suitable for indirect lighting, direct lighting and lateral lighting.*

Il cavo, realizzato in materiale termosplastico isolante, è disponibile in due differenti finiture: nero e bianco. Viene fornito maggiorato di 50 cm per agevolare la fase di installazione.

*The cable, made of insulating thermoplastic material, is available in two different finishes: black and white. It is supplied increased by 50 cm to facilitate the installation phase.*



Estensione LED può essere montato a parete, a soffitto o da parete a soffitto. Gli attacchi, con sistema a perno interno, rendono possibile la rotazione orizzontale a 180° del cavo. Infinite posizioni per infiniti utilizzi. Gli attacchi includono i tenditori. La massima lunghezza consentita dell'installazione è di 10m.

*Estensione LED can be mounted on the wall, ceiling or wall to ceiling. The connections, with an internal pin system, make it possible to rotate the cable horizontally through 180°. Infinite positions for infinite uses. The bindings include the turnbuckles. The maximum permissible length of the installation is 10m.*

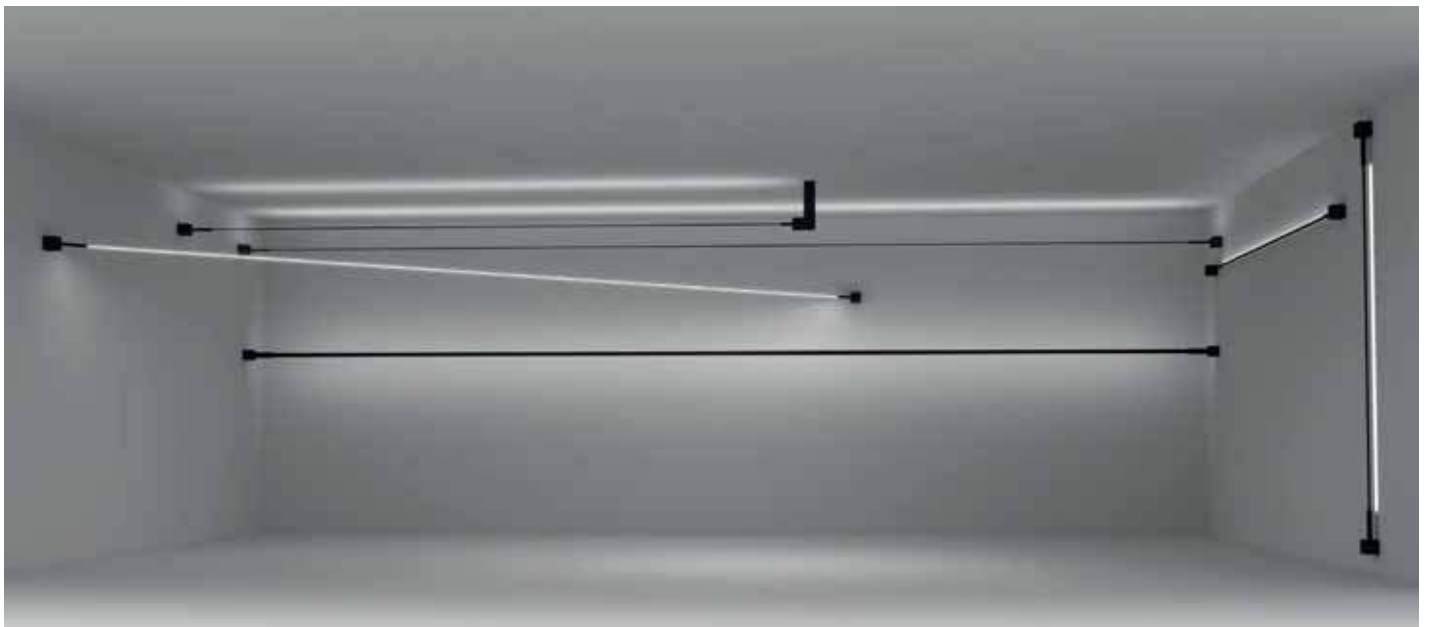

# Estensione LED, system

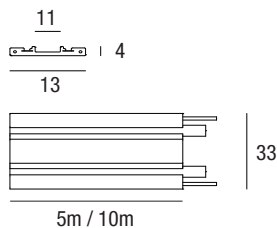

## Cavo - Cable

Colour	L. mm	pcs	Kg	Code
B	5000	001	1	R-40301
B	10000	001	2	R-40302
N	5000	001	1	R-40501
N	10000	001	2	R-40502

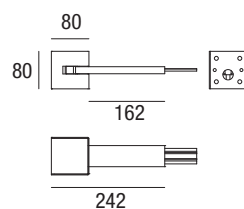
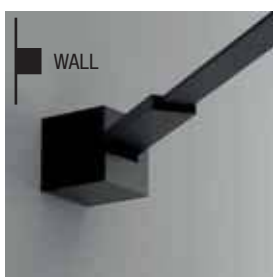

## Attacco parete - Wall fixing

Colour	pcs	Kg	Code
B	001	1,30	R-40303
N	001	1,30	R-40503

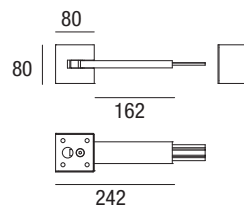

## Attacco soffitto - Ceiling fixing

Colour	pcs	Kg	Code
B	001	1,30	R-40304
N	001	1,30	R-40504

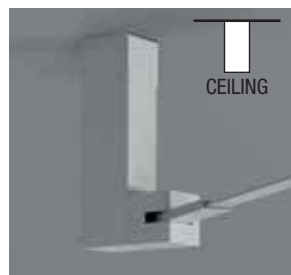

## Distanziatore soffitto (da abbinare ad attacco parete) Ceiling spacer (to be combined with wall connection)

Colour	pcs	Kg	Code
B	001	3	R-40305
N	001	3	R-40505

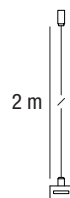

## Cavo di sostegno regolabile - Wire support adjustable

Colour	pcs	Kg	Code
B	001	0,20	R-40313
N	001	0,20	R-40513

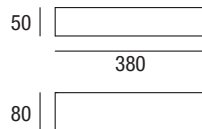

## Scatola per alimentatore - Box driver

Colour	pcs	Kg	Code
B	001	0,95	R-40318
N	001	0,95	R-40518

# Estensione LED - Flex monocromatica 48 Vdc - IP20



Per dati tecnici Strip Led, scelta dei Driver diversi da quelli consigliati e info tecniche, For Strip Led technical data, choice of Drivers other than the recommended ones and technical info.

vedi pag. see page  
422-502



colour	W/m	Led/mt *	Pitch LED	K	Lm/m	Efficiency	pcs	Kg	Width mm.	S+L
T	19,2	120	33.33	3000	1632	100	1	0,36	10	30904/48
T	19,2	120	33.33	4000	1728	100	1	0,36	10	90.012/010/48

## Accessori inclusi - Included accessories



Per codici IP20  
For IP20 codes  
Cavi di connessione al driver.  
Connection cables to the driver



Connettore per linea continua.  
Connector for continuous line.

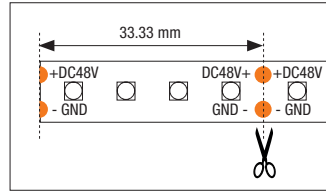

Effettuare il taglio in corrispondenza del simbolo della forbice e la linea tratteggiata.  
Make the cut in correspondence of the scissor symbol and dotted line.



# Micro LED

spot orientabile per Estensione LED System  
adjustable spot for Estensione LED System

220 240V	50/60 Hz	48Vdc	IK06	IP20	CRI 97	+40 C° -20	650°	RG0	CE	III	DRIVER NOT INCLUDED MULTIPOWER
RETAIL	MARKET	SCHOOL 1+1=2 ABC	HOTEL	HOSPITAL	OFFICE	GYM	HOME				

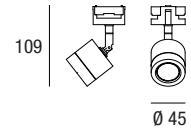

Colour	W max	V.	lm output max	K	Kg	S+L
B	9	48	728	3000	0,1	R-46331
B	9	48	770	4000	0,1	R-46332
N	9	48	728	3000	0,1	R-46531
N	9	48	770	4000	0,1	R-46532



È possibile combinare il faretto con la striscia LED desiderata, per un massimo di 14 sorgenti Micro LED Spot (Driver 150W) per tesata, inoltre è possibile la dimmerazione tramite il controller LED KZQ-4.

It is possible to combine the spotlight with the desired LED strip, for up to 14 Micro LED Spot (Driver 150W) sources per header, and dimming via the KZQ-4 LED controller is also possible.

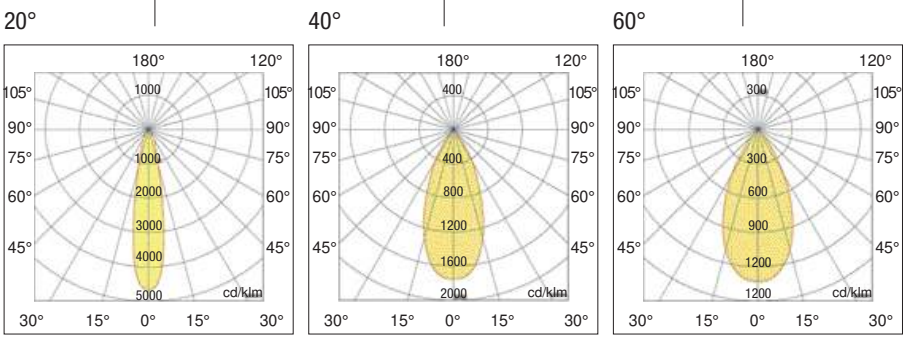
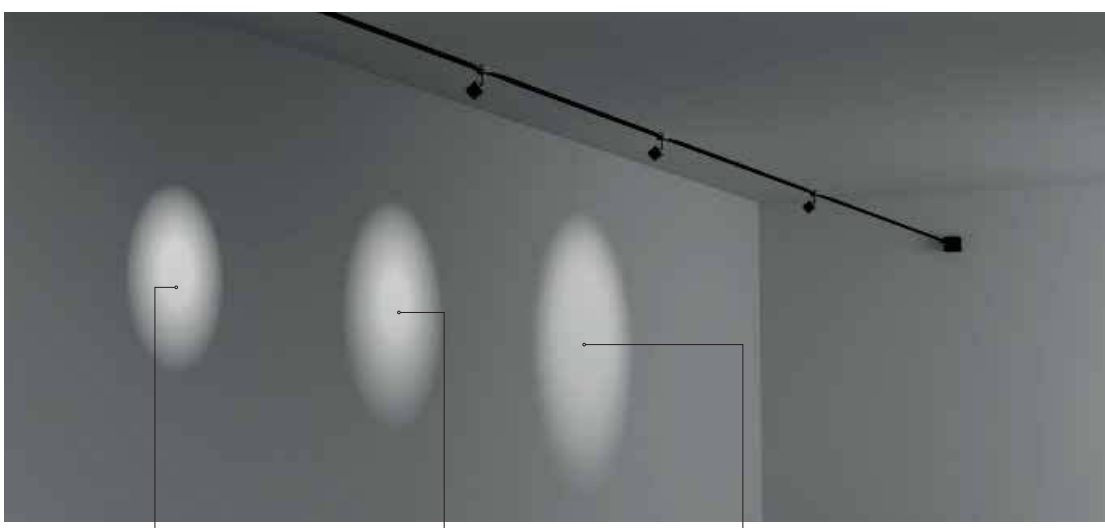

Lente (non inclusa) - Lens (not included)

Code
20°
40°
60°

A seconda della necessità è possibile scegliere la lente come accessorio non incluso.  
Depending on the need, it is possible to choose the lens as an accessory not included.

Cable Light



## driver e controller consigliati driver and controller recommended

Controller per **strisce LED** e **Spot Micro LED**  
Controller for **strip LED** and **Spot Micro LED**

**KZQ-4**  
Cod. 30949



vedi pag.  
see page

**628**

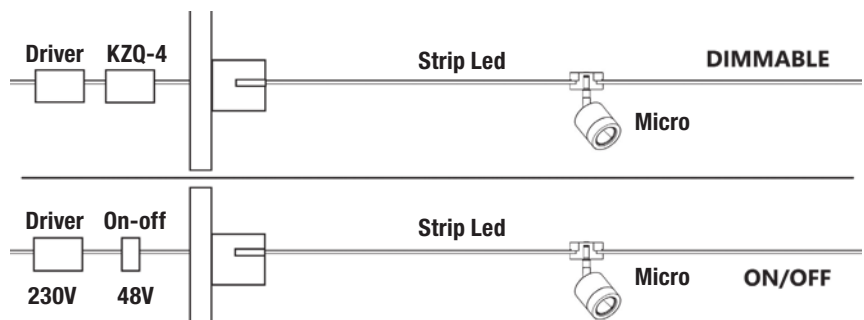

Esempio di installazione dimmerabile con KZQ-4 Codice 30949 (Push button DIM / 0-10V DIM / DALI DIM) o installazione non dimmerabile. La Strip LED e gli spot MICRO possono essere alimentati insieme (accensione unica) oppure possono essere alimentati separatamente attraverso l'utilizzo di due alimentatori (doppia accensione).

*Example of dimmable installation with KZQ-4 Code 30949 (Push button DIM / 0-10V DIM / DALI DIM) or non-dimmable installation. The LED Strip and the MICRO spots can be powered together (single switch) or they can be powered separately through the use of two power supplies (double switch).*

Treiber / Driver 48V.

SLIM CV LED DRIVER



**48Vdc**

Art.-Nr Code	Watt Range	Output current mA			Power factor	L (mm)	P (mm)	H (mm)
RN9175/48/75	75	0-1800mA	15	25A 200µS	0,95 λ	180	52	30
RN9175/48/120	120	0-2500 mA	15	25A 200µS	0,95 λ	300	40	30

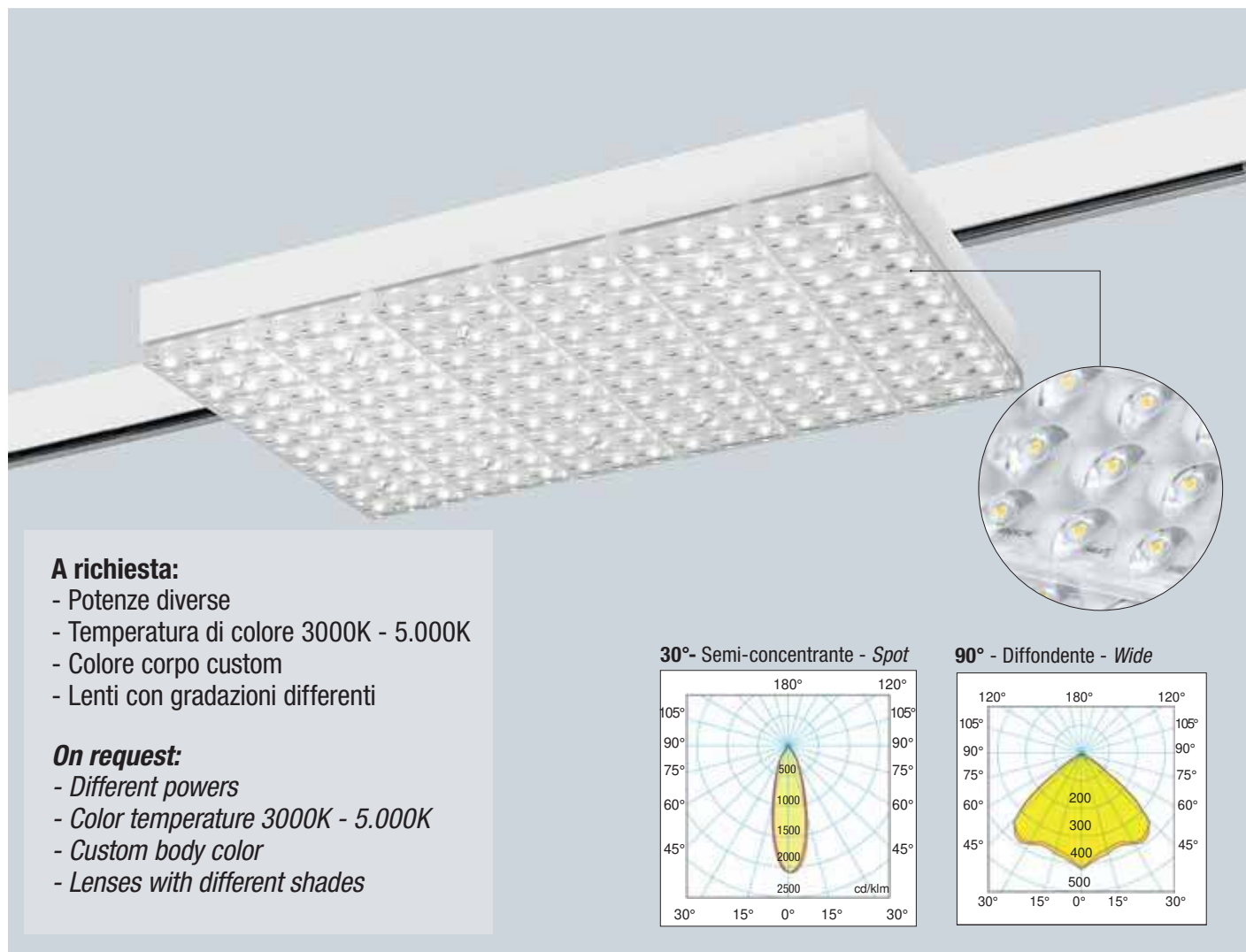

### A richiesta:

- Potenze diverse
- Temperatura di colore 3000K - 5.000K
- Colore corpo custom
- Lenti con gradazioni differenti

### On request:

- Different powers
- Color temperature 3000K - 5.000K
- Custom body color
- Lenses with different shades

30° - Semi-concentrate - Spot

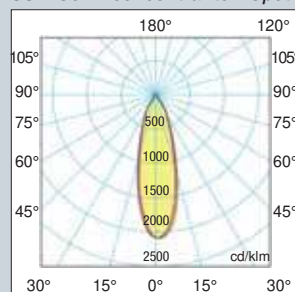

90° - Diffondente - Wide

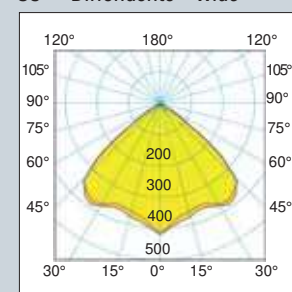

### Orientabilità - Adjustability



Apparecchi a LED compatti e potenti, di forma contenuta con spessore di soli 24mm. sono adatti ad illuminare centri commerciali, ambienti industriali e aree espositive in genere; con corpo pressofuso in alluminio di alta qualità. Adatti per musei , negozi, esposizioni, nessuna emissione di raggi UV o infrarossi (col tempo non scoloriscono ne scaldano gli oggetti).

**Corpo:** in acciaio verniciato di colore bianco RAL9010 o nero RAL9005.

**Lenti:** lenti a distribuzione ampia in metacrilato trasparente con superficie esterna chiara.

**Schermo:** tecnopolimero trasparente.

**Temperatura di colore:** 4000K.

**Conforme alla norma:** EN60598-1, RG0 nessun rischio fotobiologico ai fini della norma EN62471.

**Led:** CREE mantenimento del flusso luminoso minimo al 80%: L80B20>50.000h.

**Driver:** incluso  Fattore di potenza  $\geq 0,95$ .

**Prodotto conforme alle direttive:** 

*Triple anti-glare led track spot light with High quality aluminum diecast light body, Cold forging process on high purity metal. Perfect for art gallery and fashion shop lighting.*

*Suitable for museums, shops and displays, no UV ray or infra-red emissions (they do not cause objects to fade or heat up over time).*

**Body:** in steel painted in white RAL9010 or black RAL9005.

**Lens:** Wide distribution lenses in clear methacrylate with clear outer surface.

**Screen:** transparent polymer sheet.

**Colour temperature:** 4000K.

**Compliant with standard:** EN60598-1, RG0 no photobiological risk for the purposes mentioned in standard EN62471.

**LED:** CREE mantenimento di 80% minimo luminoso flux: L80B20>50.000h.

**Driver:** included   $\geq 0.95$  Power factor.

**Product compliant with directives:** 

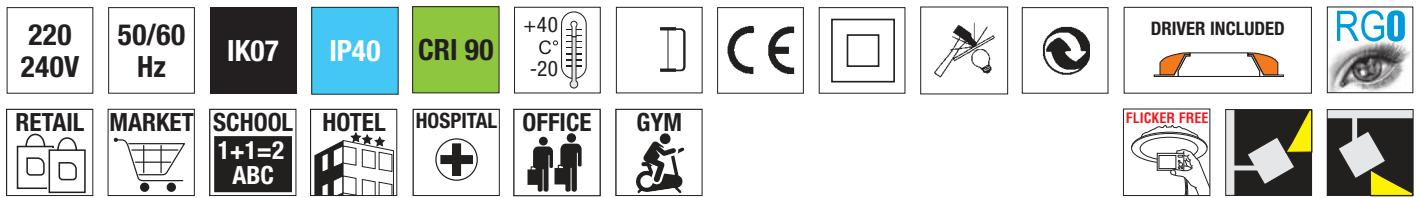

### LED Quadro trifase 37W

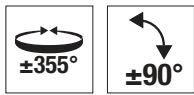
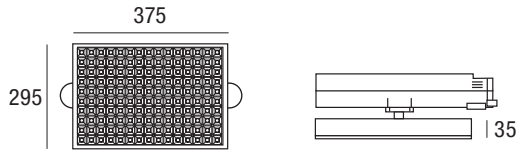

colour	W max	lm output max *	K	Beam angle	pcs	Kg	CELL
B	37	4200	4000	90°	001	3	33555-90
N	37	4200	4000	90°	001	3	33556-90
B	37	4200	4000	30°	001	3	33555-30
N	37	4200	4000	30°	001	3	33556-30
DALI 2 PUSH B	37	4200	4000	90°	001	3	33555-90-DA
DALI 2 PUSH N	37	4200	4000	90°	001	3	33556-90-DA
DALI 2 PUSH B	37	4200	4000	30°	001	3	33555-30-DA
DALI 2 PUSH N	37	4200	4000	30°	001	3	33556-30-DA

3000K 5000K

A richiesta, minimo 50 pcs, aggiungere 3K o 5K dopo il codice.  
On request, at least 50 pcs, add 3K or 5K after the code.

### LED Quadro trifase 30W

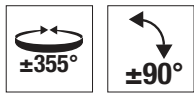
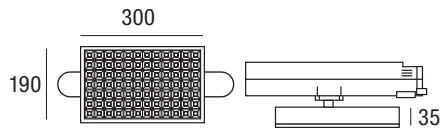

colour	W max	lm output max *	K	Beam angle	pcs	Kg	CELL
B	30	3100	4000	90°	001	2,5	33557-90
N	30	3100	4000	90°	001	2,5	33558-90
B	30	3100	4000	30°	001	2,5	33557-30
N	30	3100	4000	30°	001	2,5	33558-30
DALI 2 PUSH B	30	3100	4000	90°	001	2,5	33557-90-DA
DALI 2 PUSH N	30	3100	4000	90°	001	2,5	33558-90-DA
DALI 2 PUSH B	30	3100	4000	30°	001	2,5	33557-30-DA
DALI 2 PUSH N	30	3100	4000	30°	001	2,5	33558-30-DA

3000K

A richiesta, minimo 50 pcs, aggiungere 3K dopo il codice.  
On request, at least 50 pcs, add 3K after the code.

Fornito di dip switch per la selezione della corrente in uscita - Equipped with dip switch for selecting the current output.



Iout	mA	500	600	700	800	900	1000	1050
Power *	W	18	21	25	28	32	35	37
Lm output max **	Lm	1980	2300	2750	3080	3520	3850	4200

\* La taratura del Driver non deve in nessun caso superare la potenza (Wmax) della lampada.  
The Driver setting must in no case exceed the power (Wmax) of the lamp.

Taratura standard di fabbrica  
Driver Standard factory setting

Track light



Proiettore orientabile progettati per illuminare musei, spazi commerciali, supermercati, grandi magazzini, retail e qualsiasi ambiente dove è necessaria un'illuminazione generale e d'accento.

L'utilizzo di COB Philips ad altissima efficienza con spettri dedicati garantisce una resa illuminotecnica elevata in relazione al consumo di energia, annullando i costi di manutenzione con un notevole risparmio economico.

**Installazione:** su binario trifase Eurostandard (completo di adattatore)

**Corpo:** in alluminio pressofuso UNI 5076, verniciato con polvere termoindurente poliestere. Colore Nero opaco RAL 9005 o Bianco opaco RAL 9016.

**Orientabilità:** Z=355°, Y=90°

**Verniciatura:** di tipo poliestere eseguita a polvere

**Ottica:** concentrante e semi concentrante

**Riflettore:** segmentato premium ad alta efficienza

**Schermo:** vetro temperato di spessore 3mm

**Temperatura di colore:** 2700K, 3000K, 3500K e 4000K.

**Conforme alla norma:** EN60598-1, RG0 nessun rischio fotobiologico ai fini della norma EN62471.

**Led:** PHILIPS FORTIMO SLM C - utilizzo di COB ad altissima efficienza con spettri dedicati, mantenimento del flusso luminoso: 66.000h (L90B10).

**Driver:** incluso  Fattore di potenza ≥0,95.

Adjustable projector designed to illuminate museums, commercial spaces, supermarkets, department stores, retail and any environment where general and accent lighting is required.

The use of ultra-high efficiency Philips COBs with dedicated spectra guarantees high lighting output in relation to energy consumption, eliminating maintenance costs with significant economic savings.

**Installation:** on Eurostandard three-phase track (complete with adapter)

**Body:** in die-cast aluminum UNI 5076, painted with thermosetting polyester powder. Color Matt black RAL 9005 or Matt white RAL 9016.

**Orientability:** Z = 355 °, Y = 90 °

**Painting:** polyester type performed with powder

**Optics:** concentrating and semi-concentrating

**Reflector:** premium segmented high efficiency

**Screen:** 3 mm thick tempered glass

**Color temperature:** 2700K, 3000K, 3500K and 4000K.

**Compliant with standard:** EN60598-1, RG0 no photobiological risk for the purposes of standard EN62471.

**Led:** PHILIPS FORTIMO SLM C - use of very high efficiency COBs with dedicated spectra, luminous flux maintenance after: 66,000h (L90B10).

**Driver:** included  Power factor ≥0,95.



### Taratura/Settings DIP-SWITCH

lout	mA	300	450	550	650
Lm	Lm output	2000	2500	3000	3500
Power	W	13	19	23	27

Taratura standard di fabbrica  
Driver standard factory settings

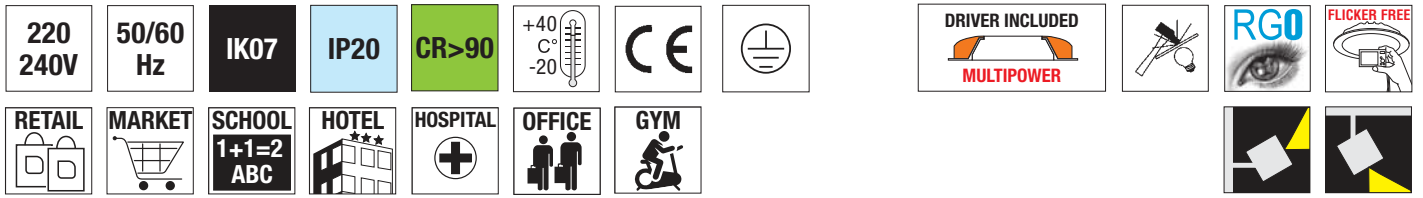

## LED Museum

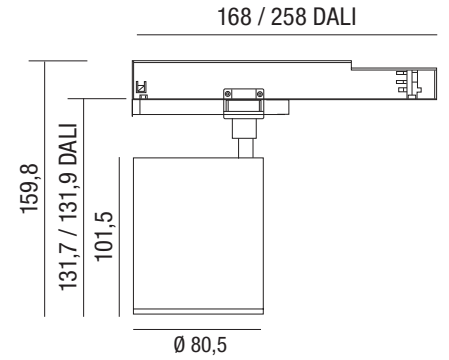

	colour	W max	K	△	pcs	Kg	CELL
	B	27	2700	30°	001	1,30	MUS2730WH
<b>DALI 2 PUSH</b>	B	27	2700	30°	001	1,30	MUS2730WHDA
	B	27	2700	40°	001	1,30	MUS2740WH
<b>DALI 2 PUSH</b>	B	27	2700	40°	001	1,30	MUS2740WHDA
	B	27	3000	30°	001	1,30	MUS3030WH
<b>DALI 2 PUSH</b>	B	27	3000	30°	001	1,30	MUS3030WHDA
	B	27	3000	40°	001	1,30	MUS3040WH
<b>DALI 2 PUSH</b>	B	27	3000	40°	001	1,30	MUS3040WHDA
	B	27	3500	30°	001	1,30	MUS3530WH
<b>DALI 2 PUSH</b>	B	27	3500	30°	001	1,30	MUS3530WHDA
	B	27	3500	40°	001	1,30	MUS3540WH
<b>DALI 2 PUSH</b>	B	27	3500	40°	001	1,30	MUS3540WHDA
	B	27	4000	30°	001	1,30	MUS4030WH
<b>DALI 2 PUSH</b>	B	27	4000	30°	001	1,30	MUS4035WHDA
	B	27	4000	40°	001	1,30	MUS4040WH
<b>DALI 2 PUSH</b>	B	27	4000	40°	001	1,30	MUS4040WHDA
	N	27	2700	30°	001	1,30	MUS2730BL
<b>DALI 2 PUSH</b>	N	27	2700	30°	001	1,30	MUS2730BLDA
	N	27	2700	40°	001	1,30	MUS2740BL
<b>DALI 2 PUSH</b>	N	27	2700	40°	001	1,30	MUS2740BLDA
	N	27	3000	30°	001	1,30	MUS3030BL
<b>DALI 2 PUSH</b>	N	27	3000	30°	001	1,30	MUS3030BLDA
	N	27	3000	40°	001	1,30	MUS3040BL
<b>DALI 2 PUSH</b>	N	27	3000	40°	001	1,30	MUS3040BLDA
	N	27	3500	30°	001	1,30	MUS3530BL
	N	27	3500	30°	001	1,30	MUS3530BLDA
	N	27	3500	40°	001	1,30	MUS3540BL
	N	27	3500	40°	001	1,30	MUS3540BLDA
<b>DALI 2 PUSH</b>	N	27	4000	30°	001	1,30	MUS4030BL
	N	27	4000	30°	001	1,30	MUS4030BLDA
	N	27	4000	40°	001	1,30	MUS4040BL
<b>DALI 2 PUSH</b>	N	27	4000	40°	001	1,30	MUS4040BLDA

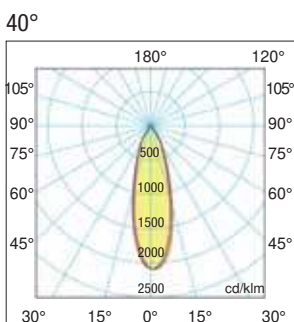
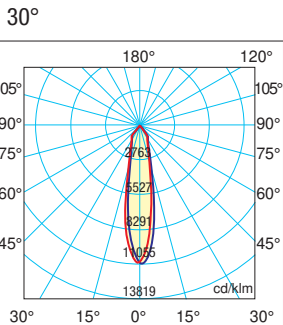



**LED Primadonna 60 - LED Primadonna RGBW**  **FULL COLOR**

Serie di proiettori orientabili progettati per illuminare spazi commerciali (supermercati, grandi magazzini, retail, ecc.), uffici e qualsiasi ambiente dove è necessaria un'illuminazione generale e d'accento.

L'utilizzo della tecnologia LED garantisce una resa illuminotecnica elevata in relazione al consumo di energia, annullando i costi di manutenzione con un notevole risparmio economico.

**Installazione:** su binario trifase Eurostandard (completo di adattatore)

**Corpo:** in alluminio pressofuso UNI 5076, verniciato con polvere termoindurente poliestere. Colore Nero opaco RAL 9005 o Bianco opaco RAL 9010.

**Orientabilità:** Z=350°, Y=90°

**Viteria:** in acciaio

**Verniciatura:** di tipo poliestere eseguita a polvere

**Ottica:** concentrante e semi concentrante

**Schermo:** vetro temperato di spessore 3mm

**Temperatura di colore:** 3000K e 4000K; altre temperature di colore a richiesta. Versione RGB.

**Conforme alla norma:** EN60598-1, RG0 nessun rischio fotobiologico ai fini della norma EN62471.

**Led:** CREE maintenance del flusso luminoso minimo al 80%: L80B20>50.000h

**Driver:** incluso  Fattore di potenza ≥0,95.

*A series of direction-adjustable flood lights designed for lighting in shopping malls (supermarkets, department stores, retail stores, etc.), offices and any facility requiring general and accent lighting. The use of LED technology guarantees high lighting engineering output in relation to energy consumption, eliminating maintenance costs and thereby offering considerable economic savings.*

**Installation:** on three-phase Eurostandard tracks (complete with adapter)

**Body:** made by UNI 5076 die-cast aluminum, coated with polyester thermoset powder.

**Adjustability:** Z=350°, Y=90°.

**Screws:** made by steel.

**Coating:** coated with powdered polyester. RAL Black 9005 or RAL 9010 White color.

**Optic:** semi-clumping.

**Optic:** clumping and semi-clumping.

**Shield:** tempered glass with 3mm thickness.

**Color temperature:** 3000K and 4000K; other color temperatures available on demand. RGB Version.

**According to standard:** EN60598-1, RG0 exempt from photobiological risks in compliance with standard EN62471.

**Led:** CREE maintenance of minimum luminous flux to 80%: L80B20>50.000h.

**Driver:** included  Power factor ≥0,95.

**Orientabilità - Adjustability**

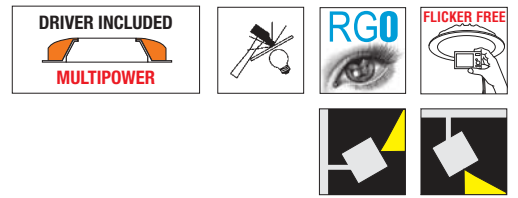
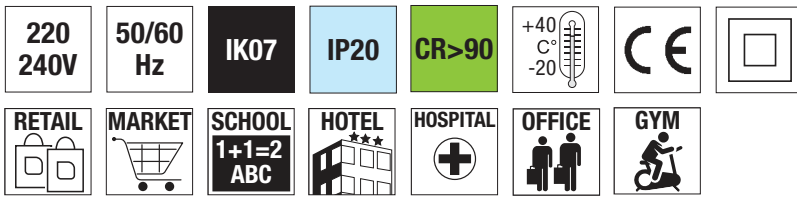

### LED Primadonna 60W



### LED Primadonna 60W

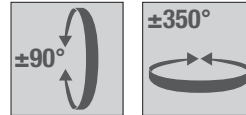
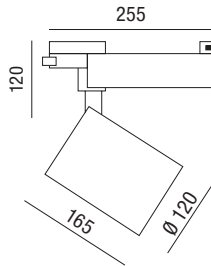

A RICHIESTA  
ON DEMAND



colour	W	lm output	K		pcs	Kg	CELL
B	60	7800	3000	40°	001	1,55	32920/60
B	60	7800	4000	40°	001	1,55	32920/60/4K
B	60	7800	3000	24°	001	1,55	32921/60
B	60	7800	4000	24°	001	1,55	32921/60/4K
N	60	7800	3000	40°	001	1,55	32922/60
N	60	7800	4000	40°	001	1,55	32922/60/4K
N	60	7800	3000	24°	001	1,55	32923/60
N	60	7800	4000	24°	001	1,55	32923/60/4K

24°

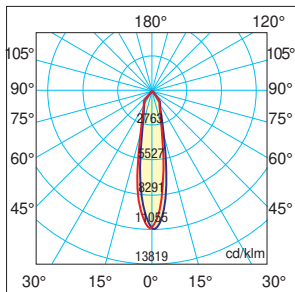

40°

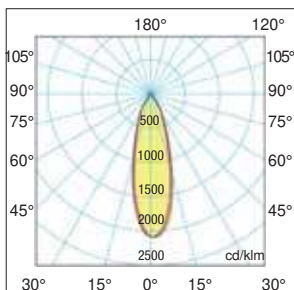

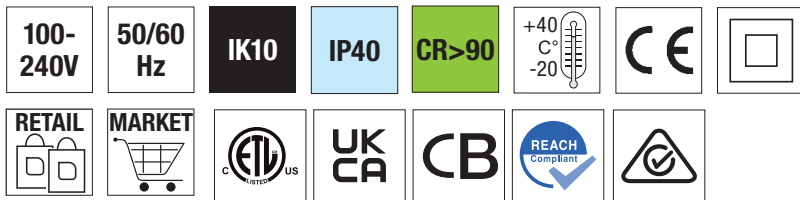

caimeta<sup>®</sup> APP



To download an app with a QR code

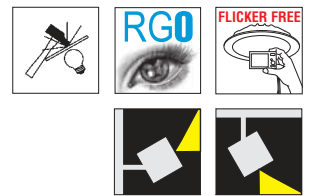

## LED Primadonna RGBW

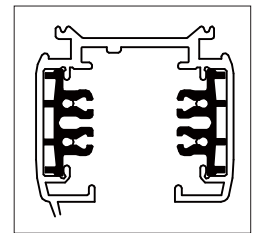
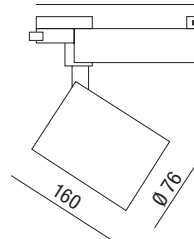

Per binario trifase a 4 fili  
For 4 wire 3 phase track

colour	W	lm output	K		pcs	Kg	CELL
<b>B</b>	30	3000	<b>FULL COLOR</b>	36°	016	0,70	32920/RGB
<b>N</b>	30	3000		36°	016	0,70	32922/RGB

- Controllabile solo con **APP Caimeta**
- 30W , IP20 , 24°
- Compatibile con Binari trifase serie: Staff, Global, Nuco, Nordic
- **AIColor**: Una funzione di illuminazione rivoluzionaria che utilizza la tecnologia AI per modificare lo spettro luminoso in base al colore ed alla categoria del prodotto, rilevati automaticamente dai sensori. L'intelligenza artificiale all'interno attiva il sistema di illuminazione per generare lo spettro luminoso migliore per ogni prodotto specificato, aumentando efficacemente le vendite e migliorando l'esperienza del cliente. (Connessione Wi-Fi obbligatoria)
- **AI Space**: Imposta scene luminose in base all'occupazione del negozio, abbassando l'intensità delle luci quando l'area è vuota. Questa soluzione sostenibile riduce le emissioni di CO2 e garantisce un'esperienza di store-brand coerente, risparmiando al contempo sui costi energetici. (Connessione Wi-Fi obbligatoria)
- **AIBBS**: Questo sistema aiuta a raccogliere i dati sugli acquisti nel negozio fisico in tempo reale, similmente a quanto avviene per gli acquisti online, dando modo di conoscere per quanto tempo un prodotto viene visionato, le scelte dei clienti e le tendenze di vendita; queste informazioni sono utili per il funzionamento del negozio (o supermercato). (Connessione Wi-Fi obbligatoria)
- Modalità automatica
- Funzionalità Master/Slave
- Piena personalizzazione dei valori RGBW e CCT

- *Commissioning only through **Caimeta APP***
- 30W , IP20 , 24°
- Works with the following track systems: Staff, Global, Nuco, Nordic
- **AIColor**: a revolutionary lighting function that utilizes AI technology to achieve an adaptive light spectrum based on automatically detected commodity category and colour. The AI algorithm inside actuates the lighting system to generate the best light spectrum for each specified commodity, effectively increasing sales and improving customer experience. (Wi-Fi connection mandatory)
- **AI Space**: It sets light scenes based on store occupancy, dimming lights when the area is empty. This sustainable solution reduces CO2 emissions and ensures a consistent brand experience while saving energy costs. (Wi-Fi connection mandatory)
- **AIBBS**: This system helps to collect the physical store shopping data, similar to the online shopping data, updated in real time. It brings the possibility to know the Product Views, Picks, and Trends; these help the store (or supermarket) operation. (Wi-Fi connection mandatory)
- Auto Mode
- Master/slave functioning
- Full customization of RGBW and CCT



Questa tecnologia consente inoltre di ottenere un bianco puro oltre a tutte le gradazioni cromatiche, senza l'influenza dei colori RGBW.

*This technology makes it possible to achieve pure white in addition to every shade of colour, without the influence of RGBW colours.*

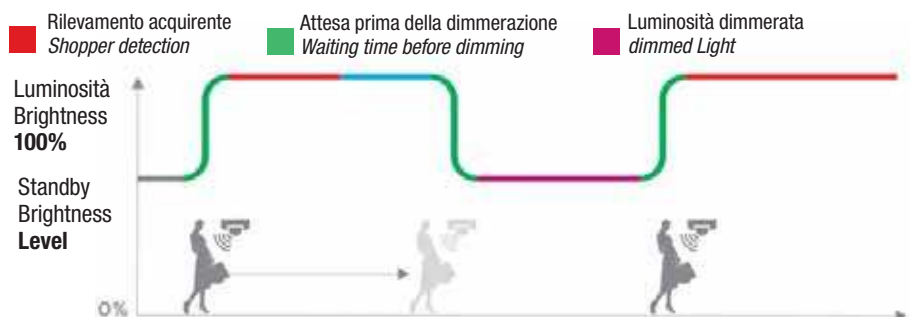
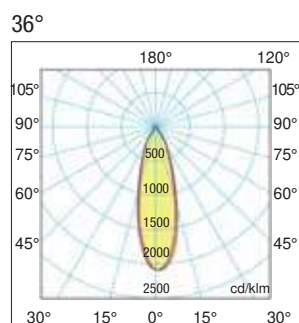

**LED Regina 3CCT**A RICHIESTA  
ON DEMAND**WIRELESS****DALI 2****3CCT**  
COLOUR  
CHANGING

Serie di proiettori orientabili 3CCT progettati per illuminare spazi commerciali (supermercati, grandi magazzini, retail, ecc.), uffici e qualsiasi ambiente dove è necessaria un'illuminazione generale e d'accento.

L'utilizzo della tecnologia LED garantisce una resa illuminotecnica elevata in relazione al consumo di energia, annullando i costi di manutenzione con un notevole risparmio economico.

**Installazione:** su binario trifase Eurostandard (completo di adattatore)

**Corpo:** in alluminio pressofuso UNI 5076, verniciato con polvere termoisolante poliester. Colore Nero opaco RAL 9005 o Bianco opaco RAL 9010.

**Orientabilità:** Z=350°, Y=90°

**Viteria:** in acciaio

**Verniciatura:** di tipo poliester eseguita a polvere

**Ottica:** concentrante e semi concentrante

**Schermo:** vetro temperato di spessore 3mm

**Temperatura di colore:** 3000K, 3500K, 4000K (3CCT).

**Conforme alla norma:** EN60598-1, RGO nessun rischio fotobiologico ai fini della norma EN62471.

**Led:** CREE mantenimento del flusso luminoso minimo al 80%: L80B20>50.000h.

**Driver:** multipower 450÷1050mA, incluso  Fattore di potenza ≥0,95.

*3CCT series of direction-adjustable flood lights designed for lighting in shopping malls (supermarkets, department stores, retail stores, etc.), offices and any facility requiring general and accent lighting.*

*The use of LED technology guarantees high lighting engineering output in relation to energy consumption, eliminating maintenance costs and thereby offering considerable economic savings.*

**Installation:** on three-phase Eurostandard tracks (complete with adapter)

**Body:** made by UNI 5076 die-cast aluminum, coated with polyester thermoset powder.

**Adjustability:** Z=350°, Y=90°.

**Screws:** made by steel.

**Coating:** coated with powdered polyester. RAL Black 9005 or RAL 9010 White color.

**Optic:** semi-clumping.

**Optic:** clumping and semi-clumping.

**Shield:** tempered glass with 3mm thickness.

**Color temperature:** 3000K, 3500K, 4000K (3CCT).

**According to standard:** EN60598-1, RGO exempt from photo-biological risks in compliance with standard EN62471.

**Led:** CREE maintenance of minimum luminous flux to 80%: L80B20>50.000h.  
**Driver:** multipower 450÷1050mA, included  Power factor ≥0,95.

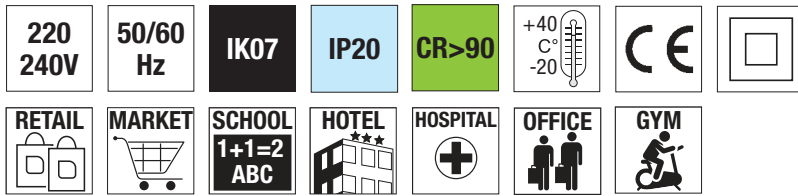

**LED Regina 3 CCT**

**NEW**

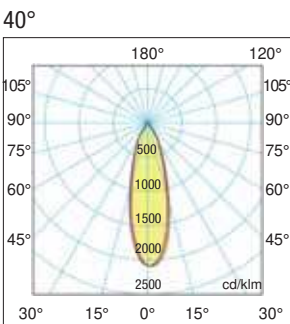
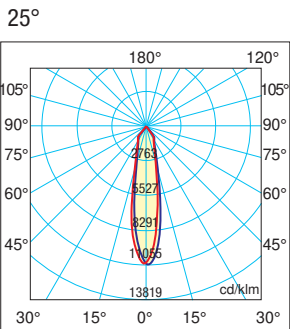
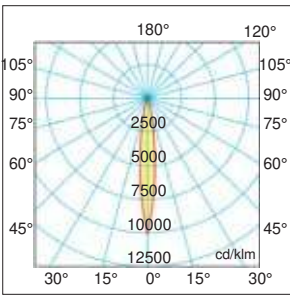

	colour	W max	K				pcs	Kg	CELL
<b>U-BOOT</b>	B	40	3000	3500	4000	15°	001	1,30	REG3CCT3015
<b>U-BOOT</b>	B	40	3000	3500	4000	15°	001	1,30	REG3CCT3015DA
<b>U-BOOT</b>	B	40	3000	3500	4000	25°	001	1,30	REG3CCT3025
<b>U-BOOT</b>	B	40	3000	3500	4000	25°	001	1,30	REG3CCT3025DA
<b>U-BOOT</b>	B	40	3000	3500	4000	40°	001	1,30	REG3CCT3040
<b>U-BOOT</b>	B	40	3000	3500	4000	40°	001	1,30	REG3CCT3040DA
<b>U-BOOT</b>	N	40	3000	3500	4000	15°	001	1,30	REG3CCT3015B
<b>U-BOOT</b>	N	40	3000	3500	4000	15°	001	1,30	REG3CCT315BDA
<b>U-BOOT</b>	N	40	3000	3500	4000	25°	001	1,30	REG3CCT3025B
<b>U-BOOT</b>	N	40	3000	3500	4000	25°	001	1,30	REG3CCT325BDA
<b>U-BOOT</b>	N	40	3000	3500	4000	40°	001	1,30	REG3CCT3040B
<b>U-BOOT</b>	N	40	3000	3500	4000	40°	001	1,30	REG3CCT340BDA

**Accessori non inclusi - Not included accessories**

**Taratura Driver DIP SWITCH - DIP SWITCH Driver setting**

**Filtri - Filters**

Colour	Code	Code
N	Frangiluce nido d'ape. Honeycomb louvre.	REG3CCT/FRA

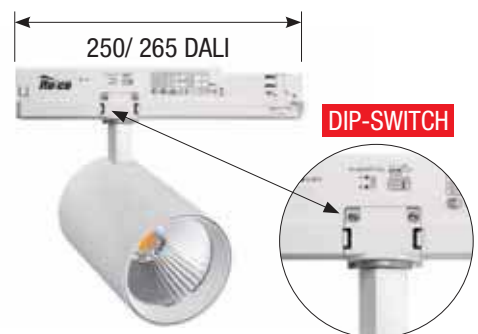

Taratura/Settings	DIP-SWITCH									
lout	mA	450	550	650	700	800	900	950	1000	1050
Lm	Lm output	2090	2530	2970	3300	3630	4070	4180	4290	4400
Power	W	19	23	27	30	33	37	38	39	40
Taratura standard di fabbrica Driver standard factory settings										

## LED Primavera Trifase

A RICHIESTA  
ON DEMAND

WIRELESS



Serie di proiettori orientabili progettati per illuminare spazi commerciali (supermercati, grandi magazzini, retail, ecc.), uffici e qualsiasi ambiente dove è necessaria un'illuminazione generale e d'accento.

L'utilizzo della tecnologia LED garantisce una resa illuminotecnica elevata in relazione al consumo di energia, annullando i costi di manutenzione con un notevole risparmio economico.

**Installazione:** su binario trifase Eurostandard (completo di adattatore).

**Corpo:** in alluminio pressofuso UNI 5076, verniciato con polvere termoisolante poliester.

**Colore:** Nero RAL 9005 o Bianco RAL 9003.

**Orientabilità:** Z=355°, Y=90°

**Viteria:** in acciaio.

**Verniciatura:** di tipo poliester eseguita a polvere.

**Ottica:** concentrante e semi concentrante.

**Schermo:** vetro temperato trasparente di spessore 3mm.

**Temperatura di colore:** 4000K.

**Conforme alla norma:** EN60598-1, RG0 nessun rischio fotobiologico ai fini della norma EN62471.

**Led:** CREE mantenimento del flusso luminoso minimo al 80%: L80B20>50.000h.

**Driver:** incluso  Fattore di potenza ≥0,95.

*A series of direction-adjustable flood lights designed for lighting in shopping malls (supermarkets, department stores, retail stores, etc.), offices and any facility requiring general and accent lighting.*

*The use of LED technology guarantees high lighting engineering output in relation to energy consumption, eliminating maintenance costs and thereby offering considerable economic savings.*

**Installation:** on three-phase Eurostandard tracks (complete with adapter)

**Body:** made by UNI 5076 die-cast aluminum, coated with polyester thermoset powder.

**Adjustability:** Z=355°, Y=90°.

**Screws:** made by steel.

**Coating:** coated with powdered polyester. Black or RAL 9010 White color.

**Optic:** semi-clumping.

**Optic:** clumping and semi-clumping.

**Shield:** 3mm thick transparent tempered glass.

**Color temperature:** 4000K.

**According to standard:** EN60598-1, RG0 exempt from photobiological risks in compliance with standard EN62471.

**Led:** CREE maintenance of minimum luminous flux to 80%: L80B20>50.000h.

**Driver:** included  Power factor ≥0,95.

## Orientabilità - Adjustability



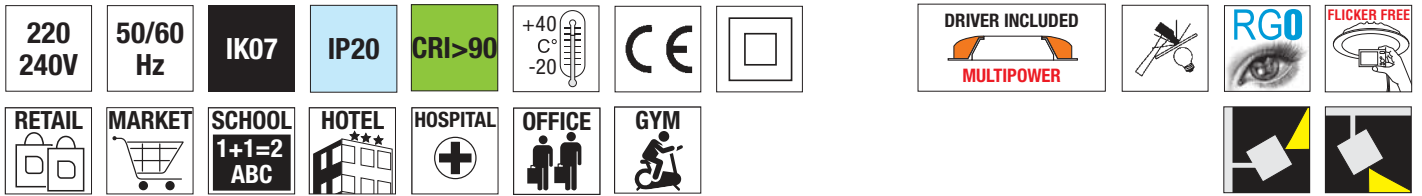

**LED Primavera trifase 20-30W**



	colour	W	K	△	pcs	Kg	CELL
	B	30	3000	40°	002	1,30	PRV30403KW
<b>DALI 2 PUSH</b>	B	30	3000	40°	002	1,30	PRV30403KWDA
	N	30	3000	40°	002	1,30	PRV30403KB
<b>DALI 2 PUSH</b>	N	30	3000	40°	002	1,30	PRV30403KBDA
	B	30	4000	40°	002	1,30	PRV30404KW
<b>DALI 2 PUSH</b>	B	30	4000	40°	002	1,30	PRV30404KWDA
	N	30	4000	40°	002	1,30	PRV30404KB
<b>DALI 2 PUSH</b>	N	30	4000	40°	002	1,30	PRV30404KBDA

15° - 25° Ottiche a richiesta - Optics on request

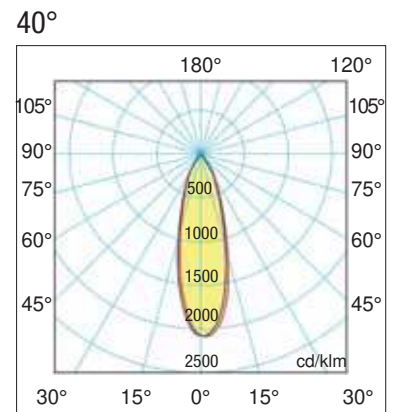

Taratura/Settings DIP-SWITCH

lout	mA	300	400	450	550	650	700
Lm	Lm output	1.690	2.210	2.470	2.990	3.510	3.770
Power	W	13	17	19	23	27	29

Taratura standard di fabbrica  
Driver standard factory settings

## LED Shop windows trifase

A RICHIESTA  
ON DEMAND

Proiettore orientabile progettato per illuminare spazi commerciali e uffici, grazie alla sua versatilità risulta particolarmente adatto per dare vita alle vetrine di negozi e qualsiasi ambiente dove è necessaria un'illuminazione generale e d'accento.

L'utilizzo della tecnologia LED garantisce una resa illuminotecnica elevata in relazione al consumo di energia, annullando i costi di manutenzione con un notevole risparmio economico.

**Installazione:** su binario trifase Eurostandard (completo di adattatore) o a parete plafone (versione C-W).

**Corpo:** in alluminio pressofuso UNI 5076, verniciato con polvere termoisolante poliester.

**Orientabilità:** Z=350°, Y=180°

**Viteria:** in acciaio

**Verniciatura:** di tipo poliester eseguita a polvere, colore nero RAL 9005 o bianco RAL 9010.

**Ottica:** concentrante e semi concentrante

**Schermo:** vetro temperato di spessore 3mm

**Temperatura di colore:** 3000K e 4000K; altre temperature di colore a richiesta.

**Conforme alla norma:** EN60598-1, RG01 nessun rischio fotobiologico ai fini della norma EN62471.

**Led:** mantenimento del flusso luminoso minimo al 80%: L80B20>50.000h.

**Driver:** incluso  Fattore di potenza ≥0,95.

*Direction-adjustable flood light designed for lighting in shopping and offices, thanks to its versatility it is particularly suitable for giving life to shop windows and any environment where general and accent lighting is required.*

*The use of LED technology guarantees high lighting engineering output in relation to energy consumption, eliminating maintenance costs and thereby offering considerable economic savings.*

**Installation:** on three-phase Eurostandard tracks (complete with adapter) or wall-ceiling (C-W version).

**Body:** made by UNI 5076 die-cast aluminum, coated with polyester thermoset powder.

**Adjustability:** Z=350°, Y=180°.

**Screws:** made by steel.

**Coating:** coated with powdered polyester, black RAL 9005 or white RAL 9010.

**Optic:** semi-clumping.

**Optic:** clumping and semi-clumping.

**Shield:** tempered glass with 3mm thickness.

**Color temperature:** 3000K and 4000K; other color temperatures available on demand.

**According to standard:** EN60598-1, RG01 exempt from photo-biological risks in compliance with standard EN62471.

**Led:** maintenance of minimum luminous flux to 80%: L80B20>50.000h.

**Driver:** included  Power factor ≥0,95.



220 240V 50/60 Hz IK07 IP20 CR>90 +40°C -20°C CE

DRIVER INCLUDED MULTIPOWER RG01 FLICKER FREE

RETAIL MARKET SCHOOL 1+1=2 ABC HOTEL HOSPITAL OFFICE GYM

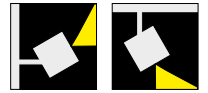

**LED Shop windows 14W**

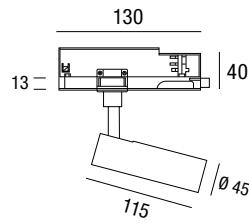

Piccolo ma potente, rimane molto discreto.  
Small but powerful, remaining very discreet.

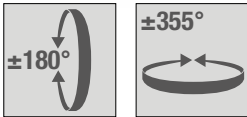

colour	W max	K	△	pcs	Kg	CELL
B	14	3000	24°	001	1,30	SCHW243KW
B	14	4000	24°	001	1,30	SCHW244KW
B	14	3000	40°	001	1,30	SCHW403KW
DALI 2 PUSH B	14	3000	40°	001	1,30	SCHW403KWDA
B	14	4000	40°	001	1,30	SCHW404KW
DALI 2 PUSH B	14	4000	40°	001	1,30	SCHW404KWDA
B	14	3000	60°	001	1,30	SCHW603KW
DALI 2 PUSH B	14	3000	60°	001	1,30	SCHW603KWDA
B	14	4000	60°	001	1,30	SCHW604KW
DALI 2 PUSH B	14	4000	60°	001	1,30	SCHW604KWDA
N	14	3000	24°	001	1,30	SCHW243KB
N	14	4000	24°	001	1,30	SCHW244KB
N	14	3000	40°	001	1,30	SCHW403KB
DALI 2 PUSH N	14	3000	40°	001	1,30	SCHW403KBDA
N	14	4000	40°	001	1,30	SCHW404KB
DALI 2 PUSH N	14	4000	40°	001	1,30	SCHW404KBDA
N	14	3000	60°	001	1,30	SCHW603KB
DALI 2 PUSH N	14	3000	60°	001	1,30	SCHW603KBDA
N	14	4000	60°	001	1,30	SCHW604KB
DALI 2 PUSH N	14	4000	60°	001	1,30	SCHW604KBDA



Accessori non inclusi  
Not included accessories

**Filtri - Filters**

Frangiluce anti abbagliamento  
Anti-glare louver

Colour	Code
N	SHOPWIN/FRA

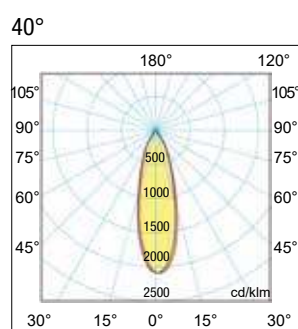
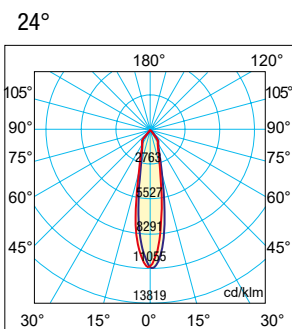

Taratura / Settings DIP-SWITCH						
Iout	mA	150	200	250	300	350
Lm	Lm output	600	800	1000	1200	1400
Power	W	6	8	10	12	14
Taratura standard di fabbrica Standard factory settings						

**NEW**

A RICHIESTA  
ON DEMAND

0-10V

DALI 2



WIRELESS

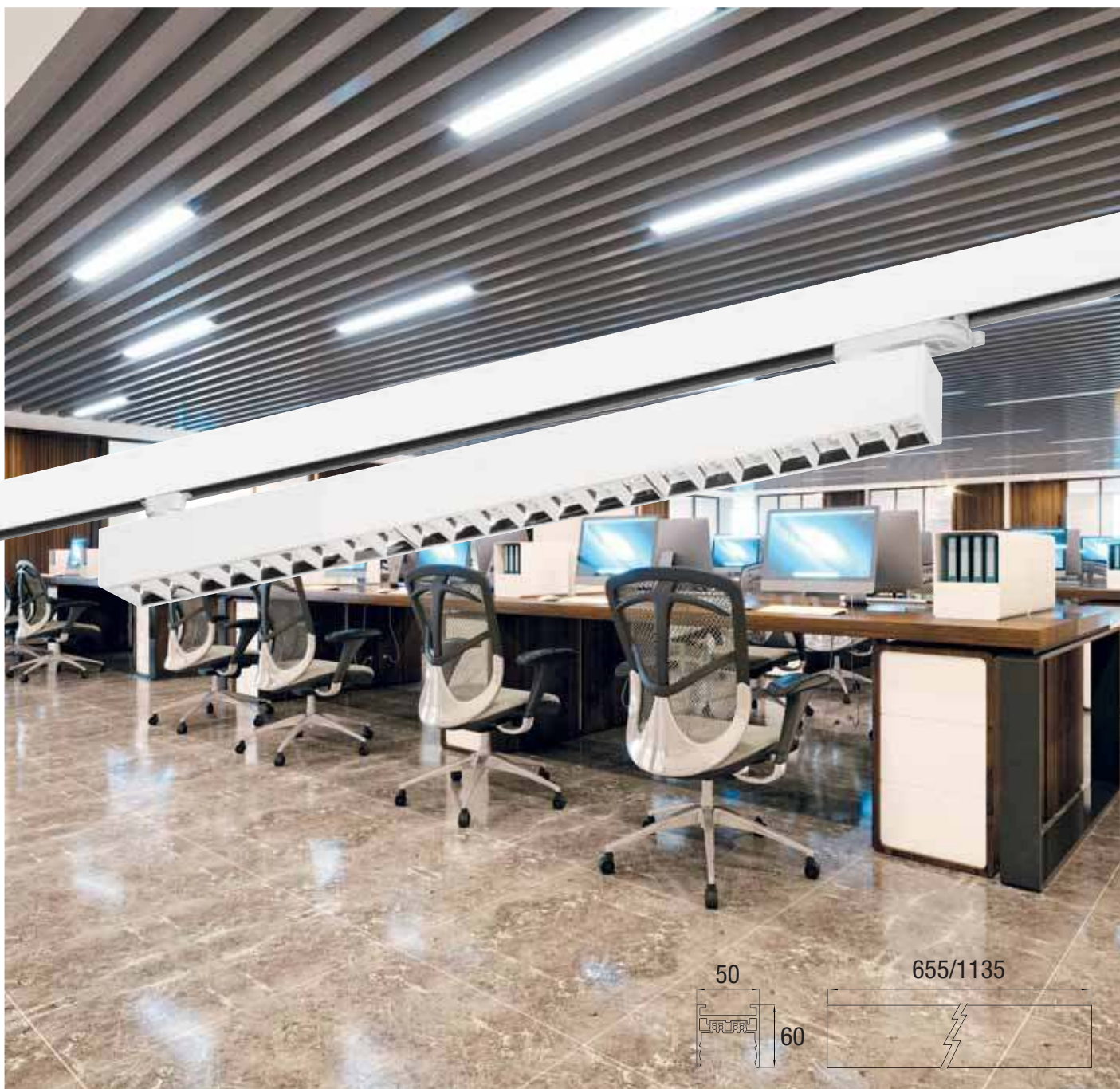

50



60

655/1135



Projecteurs sur rail

Schieneenstrahler

## LED Infinity trifase dark light.

Sistema luminoso trifase con ottica comfort dark, ideale per uffici, reception, supermarket, palestre.

**Installazione:** a binario trifase.

**Corpo:** alluminio estruso anodizzato al naturale verniciato (goffrato) a polveri epossidiche bianco RAL 9010 e nero RAL 9005.



**Ottica comfort dark:** simmetrica 65° in policarbonato metallizzato anti-abbagliamento per un miglior confort visivo.

**Conforme alla norma:** EN60598-1, RG0 nessun rischio fotobiologico ai fini della norma EN62471.

**Led:** Lumileds SMD CRI90 mantenimento del flusso luminoso minimo L80B20 > 50.000h.

**Driver multipotenza:** Incluso > 50.000 h  Fattore di potenza ≥ 0,95.

**A richiesta:** per quantità si esegue il settaggio dedicato della corrente del Driver e di conseguenza la potenza di W e Lm.

**Prodotto conforme alle direttive:**  

## LED Infinity trifase dark light.

Three-phase lighting system with comfort dark optics, ideal for offices, reception, supermarkets, gyms.

**Installation:** three-phase track.

**Body:** extruded anodized aluminum painted (embossed) with epoxy powders white RAL 9010 and black RAL 9005.

**Comfort dark optics:** symmetrical 65° in anti-glare metallized polycarbonate for better visual comfort.

**Compliant with standard:** EN60598-1, RG0 no photobiological risk for the purposes mentioned in standard EN62471.

**Led:** Lumileds SMD CRI90 maintenance of 80% minimum luminous flux: 50,000h (L80B10).

**Multipower driver:** Included > 50,000 h  Power factor ≥ 0.95.

**On request:** for quantity, the dedicated setting of the Driver current and consequently the power of W and Lm is carried out.

**Product compliant with directives:**  



220 240V	50/60 Hz	IK07	IP40	CRI 90	+40 C -20	850°	CE			DRIVER INCLUDED MULTIPOWER	RG0
RETAIL	MARKET	SCHOOL 1+1=2 ABC	HOTEL	HOSPITAL	OFFICE	GYM	TOILET	EMER	Für kabelgebundene Notlampen (nach dem Code /EM hinzufügen) 30 % Aufpreis. Bei Lichtbandversionen ist der Notfall nicht möglich. Pour les lampes filaires de secours (ajouter /EM après le code) Supplément de 30%. Urgence impossible pour les versions en ligne continue.		

### Infinity trifase

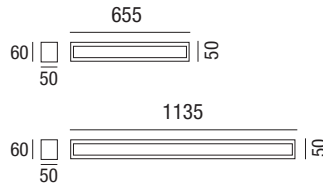

	colour	W max	Vac	lm output	lm/W	K	⊥ [mm]	Kg	CELL
	B	16	220-240	2080	130	3000	655	2.00	653KPH
	B	16	220-240	2080	130	4000	655	2.00	654KPH
	DALI 2 PUSH B	16	220-240	2080	130	3000	655	2.00	653KPHDA
	DALI 2 PUSH B	16	220-240	2080	130	4000	655	2.00	654KPHDA
	N	16	220-240	2080	130	3000	655	2.00	65B3KPH
	N	16	220-240	2080	130	4000	655	2.00	65B4KPH
	DALI 2 PUSH N	16	220-240	2080	130	3000	655	2.00	65B3KPHDA
	DALI 2 PUSH N	16	220-240	2080	130	4000	655	2.00	65B4KPHDA
	B	30	220-240	3900	130	3000	1135	2.00	1133KPH
	B	30	220-240	3900	130	4000	1135	2.00	1134KPH
	DALI 2 PUSH B	30	220-240	3900	130	3000	1135	2.00	1133KPHDA
	DALI 2 PUSH B	30	220-240	3900	130	4000	1135	2.00	1134KPHDA
	N	30	220-240	3900	130	3000	1135	2.00	113B3KPH
	N	30	220-240	3900	130	4000	1135	2.00	113B4KPH
	DALI 2 PUSH N	30	220-240	3900	130	3000	1135	2.00	113B3KPHDA
	DALI 2 PUSH N	30	220-240	3900	130	4000	1135	2.00	113B4KPHDA

Sehen:  
**Infinity S-C-Version**  
Zubehör für Dreiphasen-Stromschienenaufhängung.  
Voir:  
**Infinity S-C version**  
accessoires pour suspension de voie triphasée.

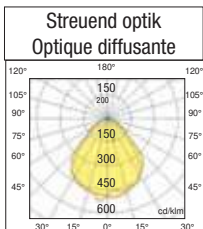



# Sky system trifase

Apparecchio singolo e fila continua  
*Single devices and continuous line*

A RICHIESTA  
ON DEMAND

WIRELESS

0-10V

DALI 2



## LED Sky slim trifase, opale, asimmetrica e bi-asimmetrica.

Sistema luminoso modulare per file continue per binario trifase in versione opale o con lenti, uffici, reception, supermarket, palestre.

**Installazione:** a binario trifase.

**Corpo:** alluminio estruso anodizzato al naturale verniciato a polveri epossidiche bianco RAL 9010 e nero RAL 9005.

**Diffusore:** in policarbonato trasparente ad incastro a filo + film microstrutturato UGR<19.

**Diffusore asimmetrico e bi-asimmetrica:** lenti in PMMA e diffusore trasparente.

**Conforme alla norma:** EN60598-1, RG0 nessun rischio fotobiologico ai fini della norma EN62471.

**Led: Samsung SMD** mantenimento del flusso luminoso minimo al 80%: L80B20>50.000h.

**Driver multipotenza:** Incluso > 50.000 h  Fattore di potenza ≥0,95.

**A richiesta:** per quantità si esegue il settaggio dedicato della corrente del Driver e di conseguenza la potenza di W e Lm.

**Prodotto conforme alle direttive:** 

## LED Sky slim three-phase, opal, asymmetrical, bi-asymmetrical.

Modular light system for continuous rows, for three-phase track, in opal version or with lenses, for offices, receptions, supermarkets, gyms.

**Installation:** Three-phase track.

**Body:** natural anodised extruded aluminium painted with white RAL 9010 and black RAL 9005 epoxy powders.

**Diffuser:** in flush joint transparent polycarbonate + microstructured film UGR<19.

**Asymmetric and bi-asymmetric diffuser:** lens in clear PMMA and transparent diffuser.

**Compliant with standard:** EN60598-1, RG0 no photobiological risk for the purposes mentioned in standard EN62471.

**Led: Samsung SMD** maintenance of 80% minimum luminous flux: 50,000h (L80B10).

**Multipower driver:** Included > 50.000 h  Power factor ≥0.95.

**On request:** for quantity, the dedicated setting of the Driver current and consequently the power of W and Lm is carried out.

**Product compliant with directives:** 

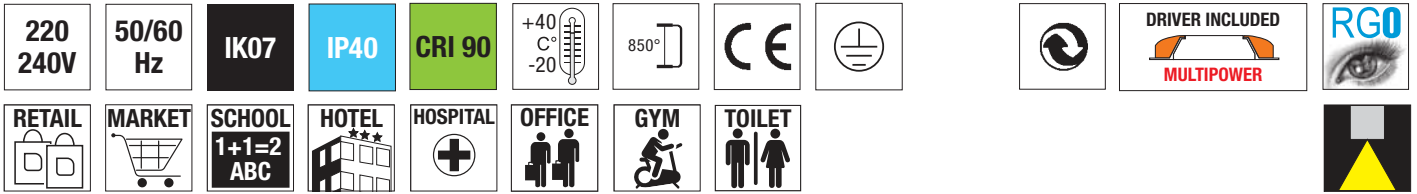

### Sky system trifase Opal

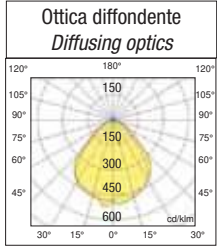

	colour	W max	Vac	lm output	lm/W	K	L (mm)	Kg	CELL
	B	30	220-240	3900	130	3000	1141	2.00	1003KPH
	B	30	220-240	3900	130	4000	1141	2.00	1004KPH
	DALI 2 PUSH B	30	220-240	3900	130	3000	1141	2.00	1003KPHDA
	DALI 2 PUSH B	30	220-240	3900	130	4000	1141	2.00	1004KPHDA
	N	30	220-240	3900	130	3000	1141	2.00	100B3KPH
	N	30	220-240	3900	130	4000	1141	2.00	100B4KPH
	DALI 2 PUSH N	30	220-240	3900	130	3000	1141	2.00	100B3KPHDA
	DALI 2 PUSH N	30	220-240	3900	130	4000	1141	2.00	100B4KPHDA
	B	50	220-240	6500	130	3000	2282	4.00	2003KPH
	B	50	220-240	6500	130	4000	2282	4.00	2004KPH
	DALI 2 PUSH B	50	220-240	6500	130	3000	2282	4.00	2003KPHDA
	DALI 2 PUSH B	50	220-240	6500	130	4000	2282	4.00	2004KPHDA
	N	50	220-240	6500	130	3000	2282	4.00	200B3KPH
	N	50	220-240	6500	130	4000	2282	4.00	200B4KPH
	DALI 2 PUSH N	50	220-240	6500	130	3000	2282	4.00	200B3KPHDA
	DALI 2 PUSH N	50	220-240	6500	130	4000	2282	4.00	200B4KPHDA

### Sky system trifase asimmetrica

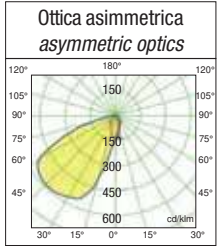
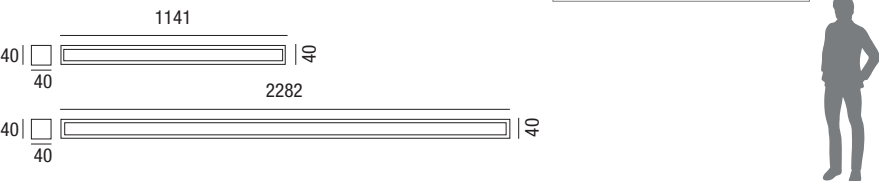

	colour	W max	Vac	lm output	lm/W	K	L (mm)	Kg	CELL
	B	30	220-240	3900	130	3000	1141	2.00	100AS3KPH
	B	30	220-240	3900	130	4000	1141	2.00	100AS4KPH
	DALI 2 PUSH B	30	220-240	3900	130	3000	1141	2.00	100AS3KPHDA
	DALI 2 PUSH B	30	220-240	3900	130	4000	1141	2.00	100AS4KPHDA
	N	30	220-240	3900	130	3000	1141	2.00	100ASB3KPH
	N	30	220-240	3900	130	4000	1141	2.00	100ASB4KPH
	DALI 2 PUSH N	30	220-240	3900	130	3000	1141	2.00	100ASB3KPHDA
	DALI 2 PUSH N	30	220-240	3900	130	4000	1141	2.00	100ASB4KPHDA
	B	50	220-240	6500	130	3000	2282	4.00	200AS3KPH
	B	50	220-240	6500	130	4000	2282	4.00	200AS4KPH
	DALI 2 PUSH B	50	220-240	6500	130	3000	2282	4.00	200AS3KPHDA
	DALI 2 PUSH B	50	220-240	6500	130	4000	2282	4.00	200AS4KPHDA
	N	50	220-240	6500	130	3000	2282	4.00	200ASB3KPH
	N	50	220-240	6500	130	4000	2282	4.00	200ASB4KPH
	DALI 2 PUSH N	50	220-240	6500	130	3000	2282	4.00	200ASB3KPHDA
	DALI 2 PUSH N	50	220-240	6500	130	4000	2282	4.00	200ASB4KPHDA

Track light

# Sky system trifase

## Sky system trifase bi-asimmetrica

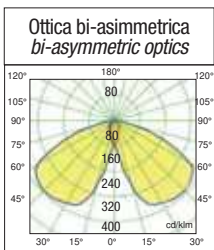
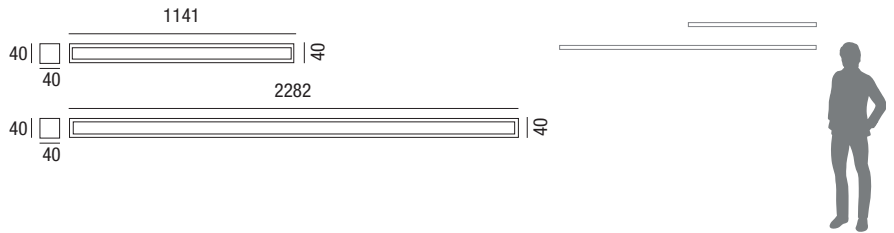

	colour	W max	Vac	lm output	lm/W	K	L (mm)	Kg	CELL
	B	30	220-240	3900	130	3000	1141	2.00	100BAS3KPH
	B	30	220-240	3900	130	4000	1141	2.00	100BAS4KPH
	DALI 2 PUSH B	30	220-240	3900	130	3000	1141	2.00	100BAS3KPHDA
	DALI 2 PUSH B	30	220-240	3900	130	4000	1141	2.00	100BAS4KPHDA
	N	30	220-240	3900	130	3000	1141	2.00	100BASB3KPH
	N	30	220-240	3900	130	4000	1141	2.00	100BASB4KPH
	DALI 2 PUSH N	30	220-240	3900	130	3000	1141	2.00	100BASB3KPHDA
	DALI 2 PUSH N	30	220-240	3900	130	4000	1141	2.00	100BASB4KPHDA
	B	50	220-240	6500	130	3000	2282	4.00	200BAS3KPH
	B	50	220-240	6500	130	4000	2282	4.00	200BAS4KPH
	DALI 2 PUSH B	50	220-240	6500	130	3000	2282	4.00	200BAS3KPHDA
	DALI 2 PUSH B	50	220-240	6500	130	4000	2282	4.00	200BAS4KPHDA
	N	50	220-240	6500	130	3000	2282	4.00	200BASB3KPH
	N	50	220-240	6500	130	4000	2282	4.00	200BASB4KPH
	DALI 2 PUSH N	50	220-240	6500	130	3000	2282	4.00	200BASB3KPHDA
	DALI 2 PUSH N	50	220-240	6500	130	4000	2282	4.00	200BASB4KPHDA



## Ottica asimmetrica Asymmetric optics

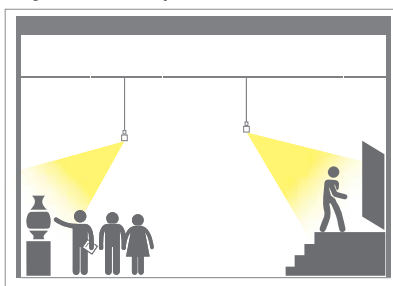

Ideale per l'illuminazione di pareti in modo uniforme.  
Ideal for lighting walls evenly.

## Ottica bi-asimmetrica Bi-asymmetric optics



Adatta per gli spazi commerciali al fine di dare maggior risalto alla merce esposta rispetto alle corsie.

Suitable for commercial spaces to allow the displayed goods to stand out respect to the lanes.

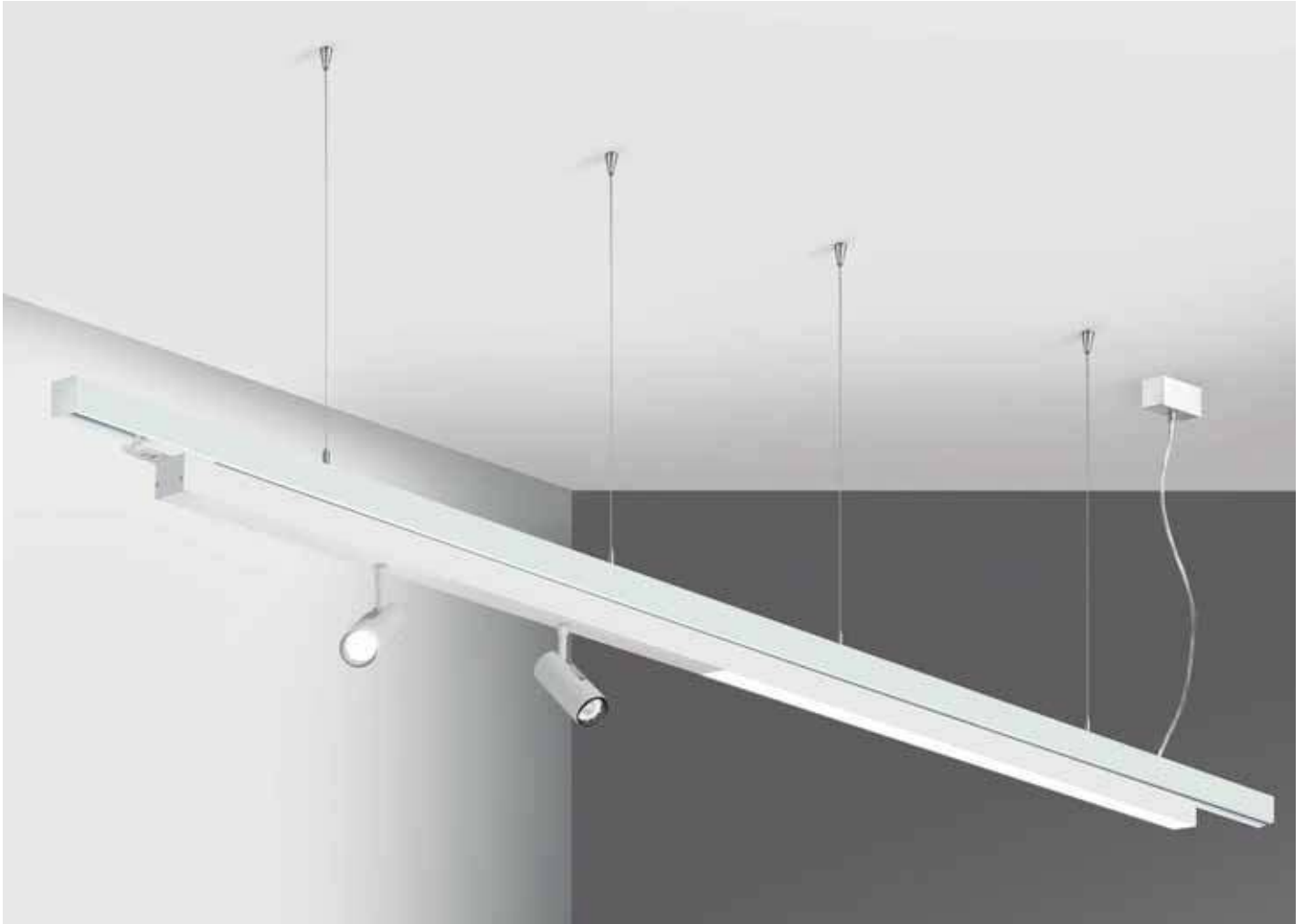

**Kit Spot**  
**Spot Kit**

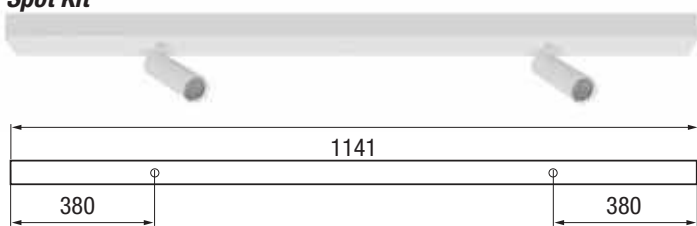

**Cover 2 spot L.1141 mm.**

Colour	W	lm output	K	Angolo	Code
B	2x10	2x1700	3000	15 (36)	2SPOT/3K/PH
B	2x10	2x1700	4000	15 (36)	2SPOT/4K/PH
N	2x10	2x1700	3000	15 (36)	2SPOT/B/3K/PH
N	2x10	2x1700	4000	15 (36)	2SPOT/B/4K/PH

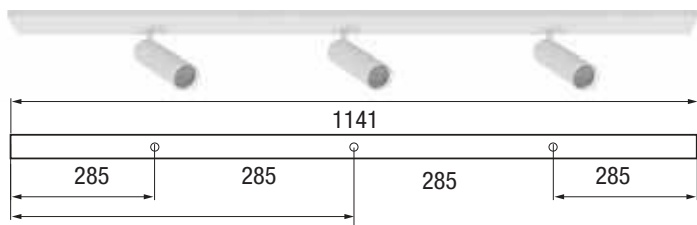

**Cover 3 spot L.1141 mm.**

Colour	W	lm output	K	Angolo	Code
B	3x10	3x1700	3000	15 (36)	3SPOT/3K/PH
B	3x10	3x1700	4000	15 (36)	3SPOT/4K/PH
N	3x10	3x1700	3000	15 (36)	3SPOT/B/3K/PH
N	3x10	3x1700	4000	15 (36)	3SPOT/B/4K/PH

**Spot 15°**

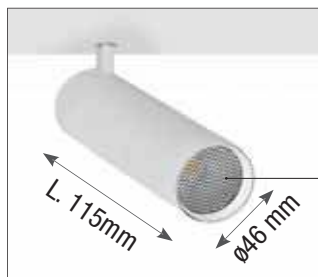
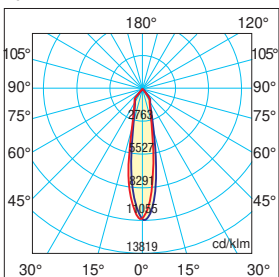

Frangiluce nido d'ape **INCLUSO**.  
**INCLUDED Honeycomb louvre**

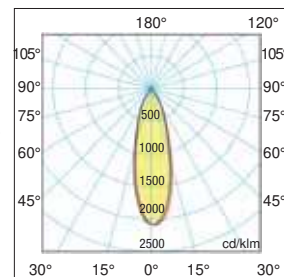

Spot 36°  
a richiesta  
*on demand*

# Sistemi di controllo per binario trifase

## Control systems for three-phase track



**Tensione Nominale**  
*Rated Voltage*  
220 ÷ 240 V

**Corrente Nominale**  
*Rated Current*  
0,20 A

**Corrente di Spunto**  
*Inrush Current*  
5 A - 50 µS

**Potenza Uscita**  
*Output Power*  
6,5 ÷ 31 W

**Standards compliance**

EN 55015  
EN 61000-3-2  
EN 61347-1  
EN 61347-2-11  
EN 61547  
EN 62311  
ETSI EN 300 328  
ETSI EN 301 489-1  
ETSI EN 301 489-17

**HBTD54...** Dimmer da binario WIRELESS, gestisce fino a 35 lampade da 30W max.  
*WIRELESS track dimmer, controls up to 35 lamps of 30W max.*



Codice Code	Colore Color
HBTD54/W	Bianco RAL 9010 White RAL 9010
HBTD54/B	Nero RAL 9005 Black RAL 9005

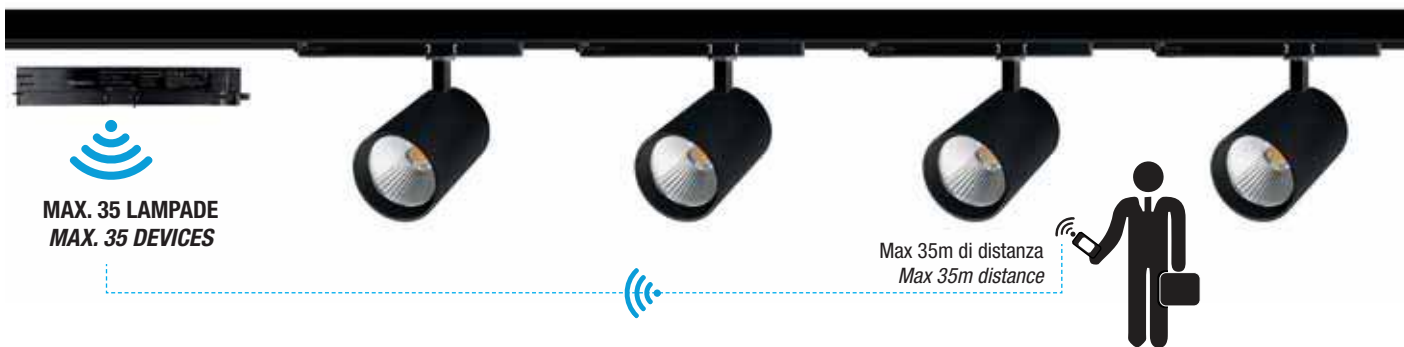
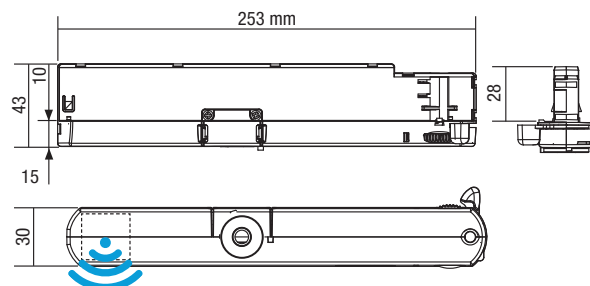

**HBIR29/TK...** Sensore di movimento WIRELESS da binario, gestisce fino a 30 lampade da 30W max.  
*Track-mounted WIRELESS motion sensor, manages up to 30 lamps of 30W max.*



Codice Code	Colore Color
HBIR29/TK/W	Bianco RAL 9010 White RAL 9010
HBIR29/TK/B	Nero RAL 9005 Black RAL 9005



RIPPLE FREE

WIRELESS

DALI

Bluetooth 5.0

\*App proprietaria  
\*Proprietary app

Vei pag.  
see page  
**204**



HED5040/BT...

Adattatore da binario WIRELESS con Driver incorporato, max 40W  
Track adapter with built-in WIRELESS LED driver, 40W max.

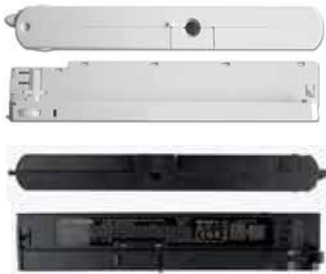

Codice Code	Colore Color
HED5040/BT/W	Bianco RAL 9010 White RAL 9010
HED5040/BT/B	Nero RAL 9005 Black RAL 9005

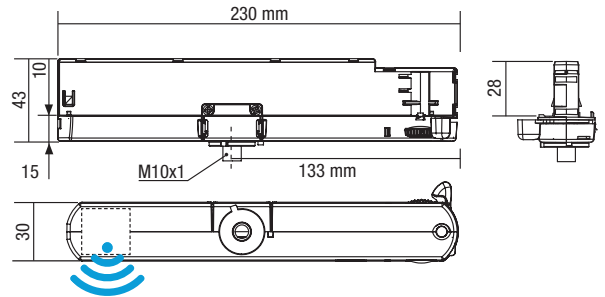

L'adattatore da binario con driver Bluetooth incorporato è applicabile a tutti i prodotti della famiglia degli spotlight trifase Relco. Questa tecnologia permette di controllare accensione/spegnimento e dimmerazione del singolo corpo luminoso in maniera autonoma\*, dando la possibilità di creare scenari luminosi specifici per ogni esigenza.

*The track adapter with built-in Bluetooth driver is applicable to all products in the Relco three-phase spotlight family. This technology allows you to control the switching on/off and dimming of the individual light body autonomously\*, giving you the possibility of creating specific lighting scenarios for every need.*

\* App Relco necessaria per programmazione  
\* Relco app required for programming



Gamma di proiettori su cui è possibile montare il dimmer o l'adattatore Wireless - Track adapter with built-in WIRELESS LED driver, 40W max.



# LED Sirio - Venere

su Binario trifase Eurostandard  
on three-phase Eurostandard tracks



220 240V 50/60 Hz IK08 IP42 IP65 +40 C° -20 CE 850°

RETAIL MARKET SCHOOL HOTEL HOSPITAL OFFICE GYM

Lampade d'emergenza  
Emergency lamps

vedi pag. see page  
478

220-240 Vac 110 Vac a richiesta on demand 50/60 Hz IP42 / IP65 IK08 M/M 850° +40 C° -20 CE

LED Sirio SE

Accessori non inclusi - Not included accessories



R00301

BINARIO CON LINEE SEPARATE  
TRACK WITH SEPARATE LINES

A richiesta  
On request

Sirio R00335SXDX

Sirio R00335DIR

Sirio R00335EX

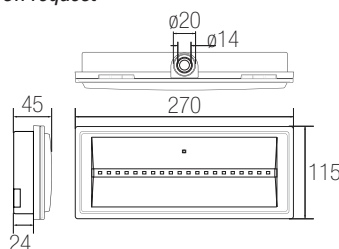

Descrizione Description	Potenza* Power W	Autonomia** Autonomy h.	Batteria Battery Ni-Cd		Ricarica Recharge h.	Flusso medio Average flow SE lm	n.-nr. LED	Assorb. max W SE	Code Code
			Volt	Ah					
SIRIO IP42 11 SE 1H V I	2W (11W*)	1 (3)	3,6	0,8	12	150	20	2,7	1956L20REL
SIRIO IP42 11 SE 3H V I	2W (11W*)	3 (9)	3,6	1,6	24	150	20	2,9	1992L20REL
SIRIO IP42 18 SE 1H V I	3W (18W*)	1 (3)	3,2	1,5	12	400	20	3,5	2046LREL

LED Venere SE

Accessori non inclusi - Not included accessories



R00301

BINARIO CON LINEE SEPARATE  
TRACK WITH SEPARATE LINES

A richiesta  
On request

Venere R00337SXDX

Venere R00337DIR

Venere R00337EX

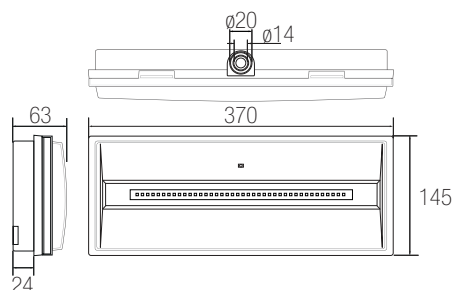

Descrizione Description	Potenza* Power W	Autonomia** Autonomy h.	Batteria Battery Ni-Cd		Ricarica Recharge h.	Flusso medio Average flow SE lm	n.-nr. LED	Assorb. max W SE	Code Code
			Volt	Ah					
VENERE IP42 24 SE 1H V I	3W (24W*)	1 (3)	3,2	1,6	12	320	40	2,9	12104L40REL
VENERE IP42 24 SE 1H V I H	3W (24W*)	1	3,2	3,0	12	700	40	3,2	12104H40REL
VENERE IP42 36 SE 1H V I H	5W (36W*)	1 (2)	3,2	6,0	12	1000	40	3,2	12104SH40REL

LED Venere SA-SE AUTOTEST

Descrizione Description	Potenza* Power W	Autonomia** Autonomy h.	Batteria Battery Ni-Cd	Ricarica Recharge h.	Flusso medio Average flow SE lm	SA lm	Assorb. max W SE		Code Code		
							Volt	Ah		SE W	SA W
VENERE IP42 24 SA-SE 1H AT C	3W (24W*)	1 (3)	3,6	1,6	12	320	320	40	1,6	6,0	12104L40ASA

Ⓝ NEMKO - Certificato di sicurezza e compatibilità elettromagnetica - Safety and electromagnetic compatibility certificate.

## 3 - Binari trifase PLUS S-C-R - Threephase tracks PLUS S-C-R

**Binari trifase PLUS SC, sospensione e plafone**  
*Threephase tracks PLUS SC, suspended or ceiling*



**Binari trifase PLUS R, incasso**  
*Recessed threephase tracks PLUS R*



**UN UNICO BINARIO PER TUTTE LE TUE IDEE DI LUCE**  
I nuovi binari Relco sono **TRIFASE PLUS**, incorporano cioè in un unico prodotto le funzionalità delle tre tipologie di binari EUROSTANDARD presenti sul mercato e sono quindi una soluzione **economicamente vantaggiosa** e con un grande valore aggiunto. Questi binari sono infatti l'investimento giusto per ogni tipo di progetto perché garantiscono la **compatibilità** con tutti i sistemi ad oggi sul mercato e lasciano la libertà di scegliere in un secondo momento la tipologia di sistema di illuminazione da adottare, dando quindi la **massima flessibilità progettuale presente e futura**. I binari TRIFASE PLUS® di Relco sono approvati FELV, prodotti in alluminio estruso con contatti in rame e parti plastiche in PVC. Sono disponibili in versione standard o da controsoffitto in due diverse colorazioni: Bianco e Nero.

**JUST ONE TRACK FOR ALL YOUR LIGHTING IDEAS**  
New Relco track system is **THREEPHASE TRACK PLUS**, it combines the functionalities of the three EUROSTANDARD tracks currently available in the market in one unique product and is therefore a **convenient solution** with a **great added value**. In fact this system is the right investment for all the kinds of projects because it guarantees **compatibility** with all the existing systems. At the same time mounting this system allows the end user to select the type of luminaire at any phase of the project, thus bringing present and future **flexibility in lighting projects**.

Relco **THREEPHASE TRACK PLUS** track system is FELV tested and approved. It is manufactured in extruded aluminium with copper contacts and pvc plastic parts. It is available in two colours: White and Black, both in standard and recessed versions.  
**On request: hidden in-built track**

**BINARI TRIFASE PLUS A 6 CONDUTTORI:**

Il sistema binario Omnitrack PLUS è un sistema misto trifase con due conduttori aggiuntivi per la gestione di un qualsiasi segnale (es: DALI, DMX, EMER ecc.).

**THREE-PHASE PLUS TRACKS with 6 conductors:**

The Omnitrack PLUS track system is a three-phase mixed system with two additional conductors for the management of any signal (e.g. DALI, DMX, EMER etc.).

			ON-OFF +	16A 440V	1A 50Vac
FELV	50/60 Hz	IK07	IP20	960°	

**BINARIO S-C, A 6 CONDUTTORI EUROSTANDARD PLUS (DIMM DALI - DMX - EM)**  
*EUROSTANDARD PLUS 6-CONDUCTOR TRACK (DIMM DALI - DMX - EM)*

Colour	A	mm	pcs	Kg	Code
B	16	1000	001	0,86	9000A-1/W-ST
N	16	1000	001	1,71	9000A-1/B-ST
B	16	2000	001	2,56	9000A-2/W-ST
N	16	2000	001	2,56	9000A-2/B-ST
B	16	3000	001	3,40	9000A-3/W-ST
N	16	3000	001	3,40	9000A-3/B-ST

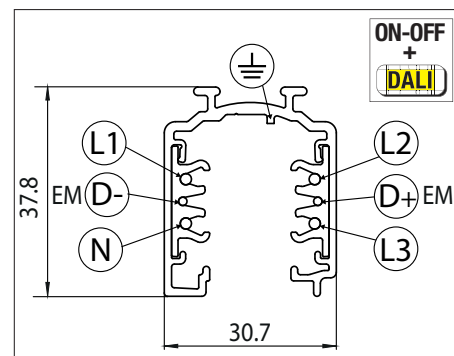

**BINARIO R, A 6 CONDUTTORI EUROSTANDARD PLUS (DIMM DALI - DMX - EM)**  
*EUROSTANDARD PLUS 6-CONDUCTOR TRACK R*

Colour	A	mm	pcs	Kg	Code
B	16	1000	001	1,10	9000-1/W-R
N	16	1000	001	1,10	9000-1/B-R
B	16	2000	001	2,10	9000-2/W-R
N	16	2000	001	2,10	9000-2/B-R

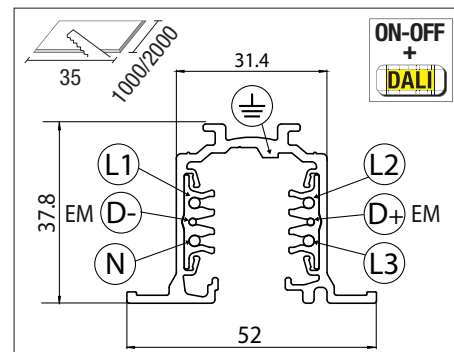
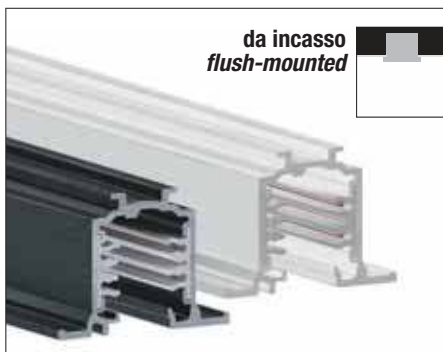

Versione per controsoffitto disponibile con l'utilizzo degli appositi accessori.

Recessed version available with specific accessories.

3 circuit Track light

## Binari trifase PLUS SC, plafone - *Threephase tracks PLUS SC, ceiling*

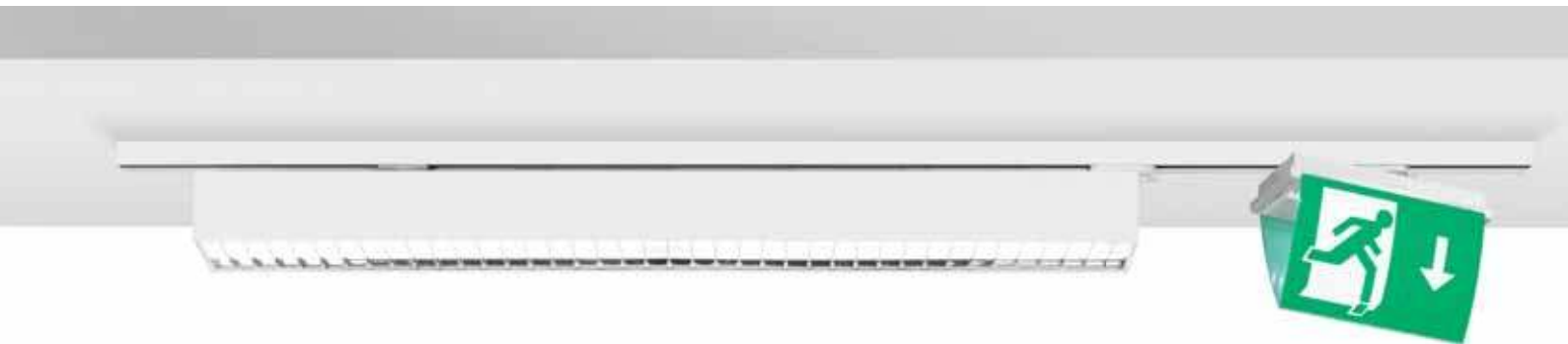

## Binari trifase PLUS R, da incasso - *Threephase tracks PLUS R, recessed*



**Adattatore simmetrico con selettore di fase**  
*Symmetrical adapter with phase selector*



Colour	A	connectors	pcs	Kg	Code
B	max 10Kg	4	010	0,05	9009-4/W
B	max 10Kg	6 DALI	010	0,05	9209/W
B	Nippel per sospensione/ <i>Suspension nipple</i>				S-9009/BC-W
N	max 10Kg	4	010	0,05	9009-4/B
N	max 10Kg	6 DALI	010	0,05	9209/B
N	Nippel per sospensione/ <i>Suspension nipple</i>				S-9009/BC-B

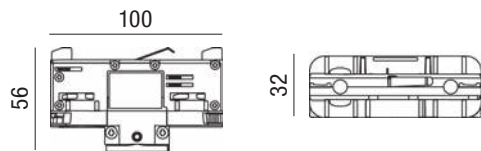

**Adattatore meccanico**  
*Mechanical adapter*



Colour		pcs	Kg	Code
B	max 15Kg	010	0,02	S-9000/M-W
N	max 15Kg	010	0,02	S-9000/M-B

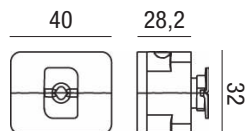

**Tutti gli accessori sono compatibili con binari trifase plus a plafone, sospensione ed incasso.**  
**All accessories are compatible with three-phase plus surface-mounted, suspended and recessed tracks.**

Tutte le connessioni sono realizzate in policarbonato autoestinguente con glow wire 960°C. Le connessioni sono disponibili in tutte le versioni necessarie per la composizione di un sistema di illuminazione complesso (posizionamento fase interno/esterno, dx/sx, come segnalato nel disegno del singolo articolo dall'apposita linea rossa Fig. 1).

All connections are made of self-extinguishing polycarbonate, glow wire 960°C. Connections are available in all versions that allow the construction of a complete lighting application (internal/external, R/L phase placement as per red line in the singular drawing Fig. 1).

→ polarità - vista dall'alto  
 → polarity ridge - floor view

### Giunto lineare Linear Joint

Colour	A	pcs	Kg	Code
B	16	010	0,05	9003/W
N	16	010	0,05	9003/B

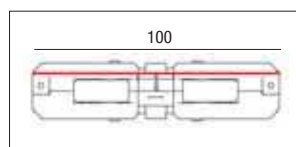

### Tappo di chiusura - End cap

Colour	pcs	Kg	Code
B	010	0,08	9004/W
N	010	0,08	9004/B
Recessed B	010	0,08	9004-R/W
Recessed N	010	0,08	9004-R/B



### Giunto diretto Middle feed

Colour	A	pcs	Kg	Code
B	16	010	0,20	9010/W
N	16	010	0,20	9010/B

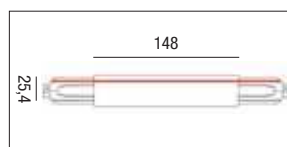

### Giunto X - X Joint

Colour	A	pcs	Kg	Code
B	16	010	0,38	9017/W
N	16	010	0,38	9017/B

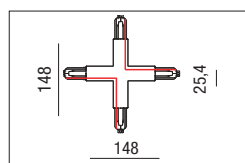

### Giunto L - L Joint

Colour	A	pcs	Kg	DX	SX
B	16	010	0,20	9011/W	9012/W
N	16	010	0,20	9011/B	9012/B

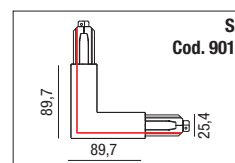
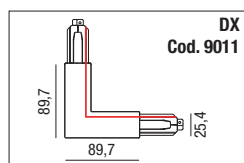

### Giunto T - T Joint

Colour	A	pcs	Kg	INT. SX *	INT. DX *
B	16	010	0,29	9016/W	9015/W
N	16	010	0,29	9016/B	9015/B

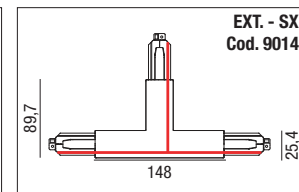
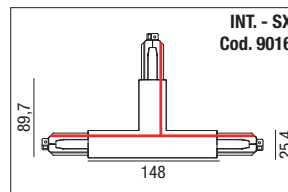

Colour	A	pcs	Kg	EXT. SX *	EXT. DX *
B	16	010	0,29	9014/W	9013/W
N	16	010	0,29	9014/B	9013/B

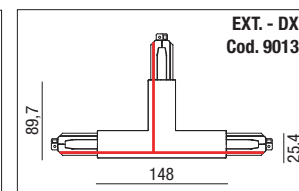
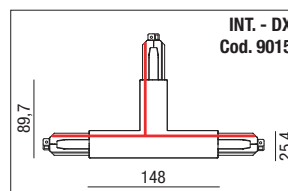

**Importante:** per il collegamento degli altri componenti tenere le polarità nella stessa posizione. La dicitura interno/esterno sta ad indicare la posizione del cavo negativo del DALI rispetto al componente.

**Important:** to connect all the other components, the polarity must be kept in the same position. The lettering Internal/External refers to the position of the negative connector for the DALI respectively to the components

**N.B:** Nel giunto interno il cavo Dali negativo passa all'interno.

**N.B:** In the internal joint, the negative DALI cable goes from within.

**N.B:** Nel giunto esterno il cavo Dali negativo passa all'esterno.

**N.B:** In the external joint, the negative DALI cable goes from the outside.

### Giunto flessibile - Adjustable corner

Colour	A	pcs	Kg	Code
B	16	010	0,24	9018/W
N	16	010	0,24	9018/B

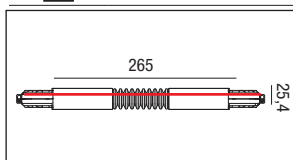

### Testata - Live end

Colour	A	pcs	Kg	SX*	DX*
B	16	010	0,10	9001/W	9002/W
N	16	010	0,10	9001/B	9002/B

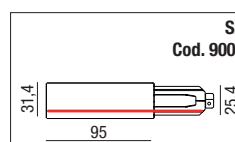
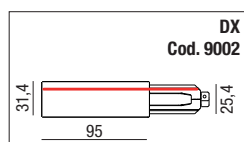

# Esempio di composizione - Example of composition

## BINARIO S-C, A 6 CONDUTTORI EUROSTANDARD PLUS EUROSTANDARD PLUS 6-CONDUCTOR TRACK

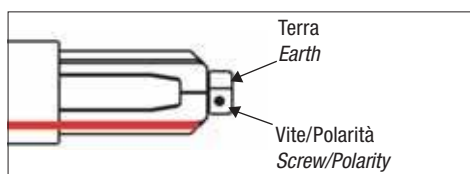
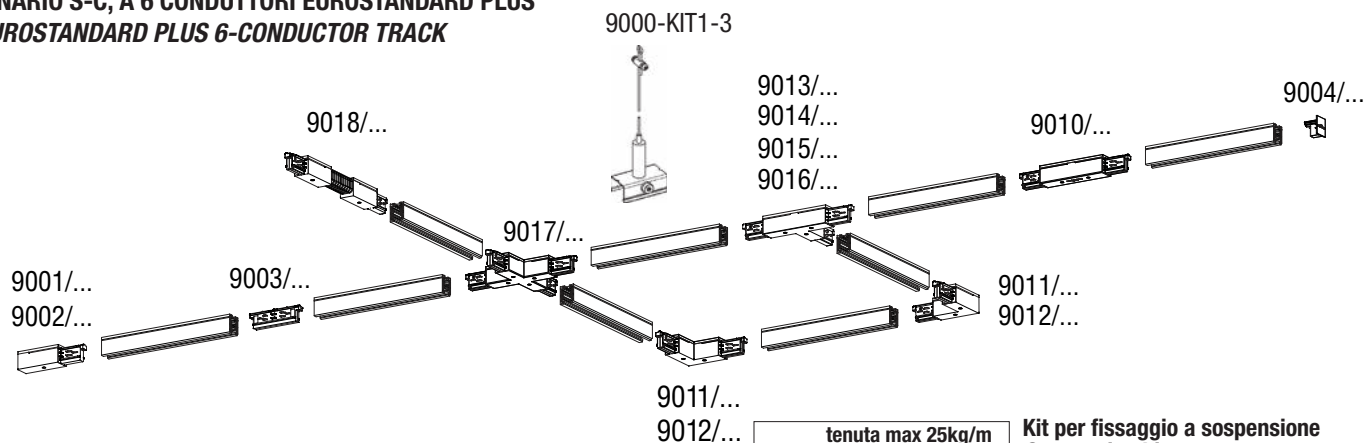

\* I riferimenti SX e DX sono dati in base alla posizione della testa della vite sulla polarità.  
SX and SX references are given having as a base the head of the screw on the polarity.

tenuta max 25kg/m  
max hold 25kg / m



### Kit per fissaggio a sospensione Suspension kit

Cod. 9000-KIT1-3  
Kit per fissaggio a sospensione composto da:

- Tenditore a vite
- Filo in acciaio Ø 1,5mm
- Lunghezza 3m
- Clip con tenditore automatico

Complete suspension Kit composed by:

- Screw gripper
- Steel cable Ø 1,5mm
- Lenght 3m
- Clamp with automatic gripper

## BINARIO R, A 6 CONDUTTORI EUROSTANDARD PLUS DA INCASSO RECESSED EUROSTANDARD PLUS 6-CONDUCTOR TRACK R

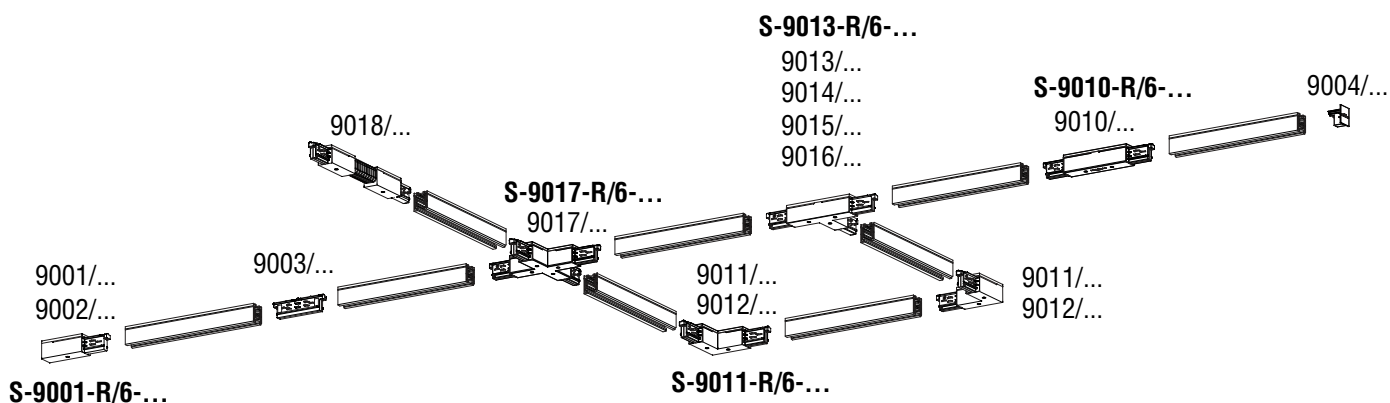

### ACCESSORI CONNESSIONI BINARIO R, INCASSO CONNECTION ACCESSORIES RECESSED TRACK

R = INCASSO / RECESSED

W = **B** B = **N**

#### Copertura per testata - Cover for end feed

Colour	pcs	Kg	Code
<b>B</b>	010	0,026	S-9001-R/6-W
<b>N</b>	010	0,026	S-9001-R/6-B



#### Copertura per giunto diretto - Cover for middle feed

Colour	pcs	Kg	Code
<b>B</b>	010	0,08	S-9010-R/6-W
<b>N</b>	010	0,08	S-9010-R/6-B

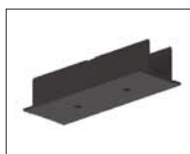

#### Copertura per giunto a L- Cover for L-feed

Colour	pcs	Kg	Code
<b>B</b>	010	0,08	S-9011-R/6-W
<b>N</b>	010	0,08	S-9011-R/6-B



#### Copertura per giunto a T- Cover for T-feed

Colour	pcs	Kg	Code
<b>B</b>	010	0,08	S-9013-R/6-W
<b>N</b>	010	0,08	S-9013-R/6-B

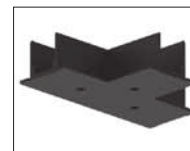

#### Copertura per giunto a X- Cover for X-feed

Colour	pcs	Kg	Code
<b>B</b>	010	0,08	S-9017-R/6-W
<b>N</b>	010	0,08	S-9017-R/6-B

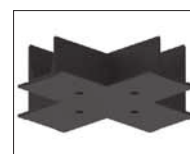

# LED Shop windows CW

**NEW**A RICHIESTA  
ON DEMAND**WIRELESS****DALI 2**

Proiettori orientabili di ridotte dimensioni, grazie alla loro versatilità risultano particolarmente adatti ad illuminare spazi commerciali e uffici possono essere inseriti in qualsiasi ambiente dove è necessaria un'illuminazione generale e d'accento, la versione con interruttore trova il suo utilizzo come abat jour il diffusore a nido d'ape distribuisce la luce in modo uniforme senza abbagliamenti.

L'utilizzo della tecnologia LED garantisce una resa illuminotecnica elevata in relazione al consumo di energia, annullando i costi di manutenzione con un notevole risparmio economico.

**Installazione:** a parete plafone.

**Corpo:** in alluminio pressofuso UNI 5076, verniciato con polvere termoisolante poliestere.

**Orientabilità:** Z=350°, Y=180°

**Viteria:** in acciaio.

**Verniciatura:** di tipo poliestere eseguita a polvere, colore nero RAL 9005 o bianco RAL 9010.

**Ottica:** semi concentrante

**Schermo:** vetro temperato di spessore 3mm

**Temperatura di colore:** 3000K e 4000K; 2700K a richiesta.

**Conforme alla norma:** EN60598-1, RG01 nessun rischio fotobiologico ai fini della norma EN62471.

**Led:** mantenimento del flusso luminoso minimo al 80%: L80B20>50.000h.

**Driver:** incluso  Fattore di potenza ≥0,95.

*Adjustable spotlights of small dimensions, thanks to their versatility they are particularly suitable for illuminating commercial spaces and offices, they can be inserted in any environment where general and accent lighting is required, the version with switch finds its use as a lampshade, the honeycomb diffuser distributes the light uniformly without glare.*

*The use of LED technology guarantees high lighting engineering output in relation to energy consumption, eliminating maintenance costs and thereby offering considerable economic savings.*

**Installation:** wall-ceiling.

**Body:** made by UNI 5076 die-cast aluminum, coated with polyester thermoset powder.

**Adjustability:** Z=350°, Y=180°.

**Screws:** made by steel.

**Coating:** coated with powdered polyester, black RAL 9005 or white RAL 9010.

**Optic:** semi-clumping.

**Shield:** tempered glass with 3mm thickness.

**Color temperature:** 3000K and 4000K; 2700K on request.

**According to standard:** EN60598-1, RG01 exempt from photo-biological risks in compliance with standard EN62471.

**Led:** maintenance of minimum luminous flux to 80%: L80B20>50.000h.

**Driver:** included  Power factor ≥0,95.





### LED Shop windows 14W

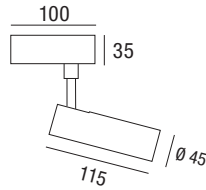

Piccolo ma potente e molto discreto.  
Small but powerful and very discreet.

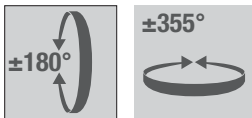

colour	W max*	K	△	pcs	Kg	CELL
B	14	3000	40°	001	1,30	SW403KCWW
<b>DALI 2</b> B	14	3000	40°	001	1,30	SW403KCWWDA
B	14	4000	40°	001	1,30	SW404KCWW
<b>DALI 2</b> B	14	4000	40°	001	1,30	SW404KCWWDA
N	14	3000	40°	001	1,30	SW403KCWB
<b>DALI 2</b> N	14	3000	40°	001	1,30	SW403KCWBDA
N	14	4000	40°	001	1,30	SW404KCWB
<b>DALI 2</b> N	14	4000	40°	001	1,30	SW404KCWBDA

A richiesta: versione 2700K  
On demand: 2700K version

#### Taratura/Settings DIP-SWITCH

lout	mA	150	200	250	300	350
Lm	Lm output	600	800	1000	1200	1400
Power	W*	6	8	10	12	14

Taratura standard di fabbrica  
Standard factory settings

40° - 14W

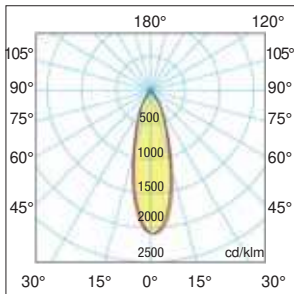

### LED Bedroom Light

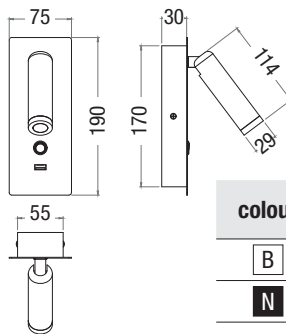

colour	W max	K	△	pcs	Kg	CELL
B	3	3000	40°	001	0,54	BRL3W3KW
N	3	3000	40°	001	0,54	BRL3W3KB

A richiesta: versione 2700K  
On demand: 2700K version



40° - 3W

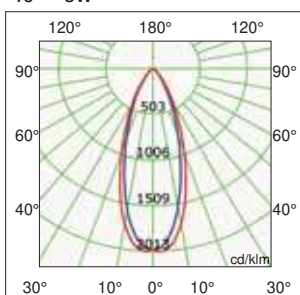

Corpo in alluminio  
Aluminum body



Con interruttore e presa USB  
With switch and USB socket



# LED Audace C-W-R



Serie von schwenkbaren Strahlern für die Aufbau- oder Halbeinbaumontage zur Beleuchtung von Umgebungen, in denen Allgemein- und Akzentbeleuchtung erforderlich ist.

**Installation:** an Decke und/oder Wand

**Körper:** aus Aluminium-Druckguss UNI 5076 mit thermisch gehärteter Polyester-Pulverlackierung.

**Lackierung:** Polyester-Pulverlackierung.

Farbe Schwarz RAL 9005 oder Weiß RAL 9010.

**Optik:** halbkonzentrierend 36°, auf Anfrage 12°, 24° oder 45°.

**Schirm:** 3 mm starkes Hartglas.

**Driver:** dimmbar 0-10 V, integriert.

**Entspricht der Norm:** EN60598-1, RG0 keine photobiologische Gefährdung im Sinne der Norm EN62471.

**LED LUMILEDS - PHILIPS:** Beibehaltung des Mindestlichtstroms von 80%: L80B20>50.000h.

*Série de projecteurs au plafond ou semi-encastrés orientables, conçus pour éclairer les espaces dans lequel un éclairage général et d'accentuation est nécessaire.*

*Installation : au plafond et/ou murale.*

**Corps :** en aluminium moulé sous pression UNI 5076, peint à la poudre thermodurcissable polyester.

**Peinture :** de type polyester, effectuée à la poudre.

Couleur noire RAL 9005 ou blanche RAL 9010.

**Optique :** à semi-concentration à 36° (sur demande 12°, 24° ou 45°).

**Écran :** verre trempé de 3 mm d'épaisseur.

**Driver :** dimmable 0-10 V incorporé.

**Conforme à la norme :** EN60598-1, RG0 aucun risque photo-biologique selon la norme EN62471.

**LED LUMILEDS - PHILIPS :** maintien du flux lumineux minimum à 80 % : L80B20>50.000h.

## Ausrichtbarkeit - Orientabilité



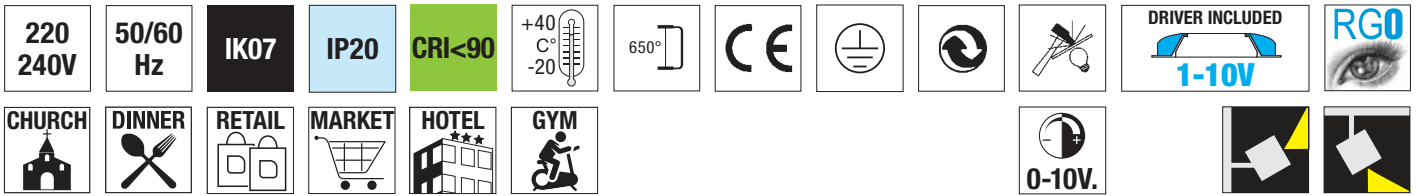

### LED Audace C-W

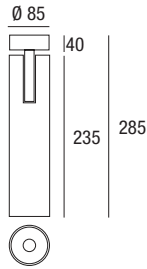

	colour	W	lm output	K		pcs	Kg	CELL
<b>0-10V</b>	B	32	3840	3000	40°	001	1,44	32928/010
<b>0-10V</b>	B	32	3840	4000	40°	001	1,44	32928/010/4K
<b>0-10V</b>	N	32	3840	3000	40°	001	1,44	32929/010
<b>0-10V</b>	N	32	3840	4000	40°	001	1,44	32929/010/4K

### LED Audace R

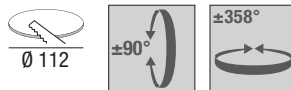
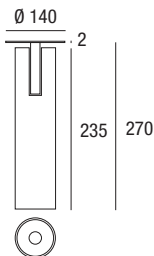

	colour	W	lm output	K		pcs	Kg	CELL
<b>0-10V</b>	B	32	4160	3000	40°	001	1,44	32930/010
<b>0-10V</b>	B	32	4160	4000	40°	001	1,44	32930/010/4K
<b>DALI 2 PUSH</b>	B	32	4160	3000	40°	001	1,44	32930/DA
<b>DALI 2 PUSH</b>	B	32	4160	4000	40°	001	1,44	32930/DA/4K



# LED Primavera C-W-R

A RICHIESTA  
ON DEMAND

0-10V



WIRELESS



Serie di proiettori a plafone (C), parete (W) o semincasso (R) orientabili progettati per illuminare ambienti dove è necessaria un'illuminazione generale e d'accento.

**Installazione:** a soffitto, parete o semincasso.

**Corpo:** in alluminio pressofuso UNI 5076, verniciato con polvere termoindurente poliestere.

**Verniciatura:** di tipo poliestere eseguita a polvere.

Colore nero RAL 9005 o Bianco RAL 9010.

**Ottica:** semi concentrante a 36° (a richiesta 12°, 24° o 45°).

**Schermo:** vetro temperato di spessore 3mm.

**Driver Multipower:** incluso

**Conforme alla norma:** EN60598-1, RGO nessun rischio fotobiologico ai fini della norma EN62471.

**Led:** LUMILEDS - PHILIPS mantenimento del flusso luminoso minimo al 80%: L80B20>50.000h.

*Series of ceiling or semi-recessed adjustable projectors designed to light up place that requires general and spot lighting.*

*Installation: ceiling, wall or semi-recessed.*

*Body: made by UNI 5076 die-cast aluminum, coated with polyester thermoset powder.*

*Coating: coated with powdered polyester. RAL 9005 black or RAL 9010 white color.*

*Optic: semi-clumping at 36° (on request 12°, 24° o 45°).*

*Shield: tempered glass with 3mm thickness.*

*Driver Multipower: included.*

*According to standard: EN60598-1, RGO exempt from photobiological risks in compliance with standard EN62471.*

*Led: LUMILEDS - PHILIPS maintenance of minimum luminous flux to 80%: L80B20>50.000h.*



Rotazione  
Rotation

±358°



±90°

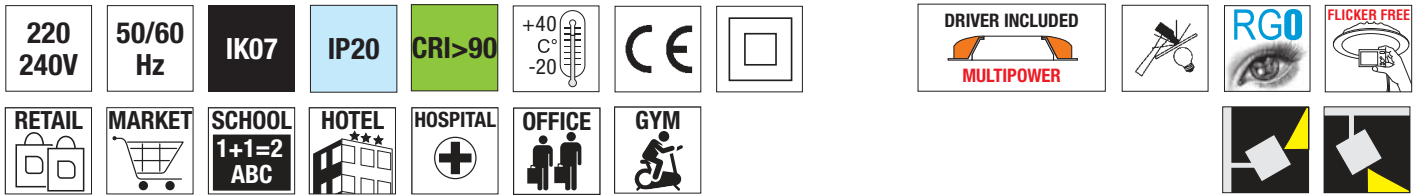

### LED Primavera C-W

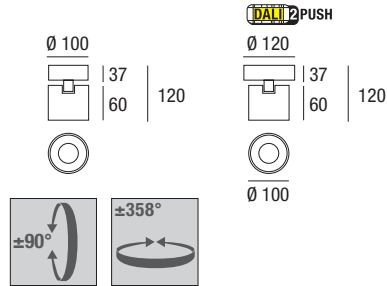

	colour	W	lm output	K		pcs	Kg	CELL
	B	30	3900	3000	40°	001	1,44	PRV303KWCV
	B	30	3900	4000	40°	001	1,44	PRV304KWCV
	<b>DALI 2</b> PUSH B	30	3900	3000	40°	001	1,44	PRV303KWCVDA
	<b>DALI 2</b> PUSH B	30	3900	4000	40°	001	1,44	PRV304KWCVDA
	N	30	3900	3000	40°	001	1,44	PRV303KBCV
	N	30	3900	4000	40°	001	1,44	PRV304KBCV
	<b>DALI 2</b> PUSH N	30	3900	3000	40°	001	1,44	PRV303KBCVDA
	<b>DALI 2</b> PUSH N	30	3900	4000	40°	001	1,44	PRV304KBCVDA

15° - 25° Ottiche a richiesta - *Optics on request*

### LED Primavera RR

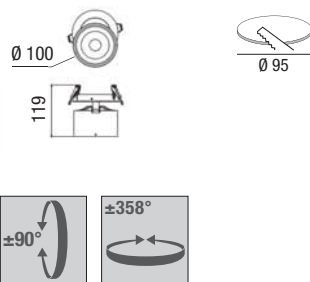

	colour	W	lm output	K		pcs	Kg	CELL
	B	30	3900	3000	40°	001	1,44	PRV303KWRR
	B	30	3900	4000	40°	001	1,44	PRV304KWRR
	<b>DALI 2</b> PUSH B	30	3900	3000	40°	001	1,44	PRV303KWRRDA
	<b>DALI 2</b> PUSH B	30	3900	4000	40°	001	1,44	PRV304KWRRDA
	N	30	3900	3000	40°	001	1,44	PRV303KBRR
	N	30	3900	4000	40°	001	1,44	PRV304KBRR
	<b>DALI 2</b> PUSH N	30	3900	3000	40°	001	1,44	PRV303KBRRDA
	<b>DALI 2</b> PUSH N	30	3900	4000	40°	001	1,44	PRV304KBRRDA

15° - 25° Ottiche a richiesta - *Optics on request*

# LED Primadonna C-W



Serie di proiettori orientabili progettati per illuminare spazi commerciali (supermercati, grandi magazzini, retail, ecc.), uffici e qualsiasi ambiente dove è necessaria un'illuminazione generale e d'accento.

**Installazione:** a soffitto e parete (completo di basetta di fissaggio).

**Corpo:** in alluminio pressofuso UNI 5076, verniciato con polvere termoindurente poliesteri.

**Verniciatura:** di tipo poliesteri eseguita a polvere. Colore nero RAL 9005 o Bianco RAL 9010.

**Ottica:** semi concentrante (a richiesta concentrante).

**Schermo:** vetro temperato di spessore 3mm.

**Driver:** ON-OFF - **DALI 2 PUSH** incorporato.

**Conforme alla norma:** EN60598-1, RG0 nessun rischio fotobiologico ai fini della norma EN62471.

**Led:** LUMILEDS - **PHILIPS** mantenimento del flusso luminoso minimo al 80%: L80B20>50.000h.

*Series of adjustable projectors designed to light up retail spaces (supermarkets, department stores, shops, etc.), offices and any other place that requires general and spot lighting.*

**Installation:** for ceiling and wall use (complete with fixing base).

**Body:** made by UNI 5076 die-cast aluminum, coated with polyester thermoset powder.

**Coating:** coated with powdered polyester. RAL 9005 black or RAL 9010 white color.

**Optic:** semi-clumping (clumping on demand).

**Shield:** tempered glass with 3mm thickness.

**Driver:** included ON-OFF - **DALI 2 PUSH**.

**According to standard:** EN60598-1, RG0 exempt from photobiological risks in compliance with standard EN62471.

**Led:** LUMILEDS - **PHILIPS** maintenance of minimum luminous flux to 80%: L80B20>50.000h.



## Orientabilità - Adjustability



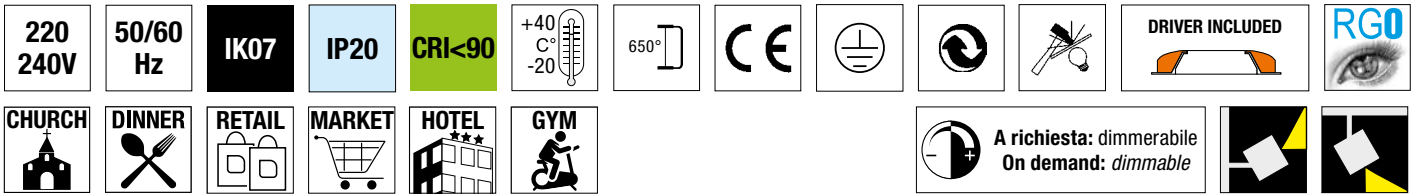

### LED Primadonna C-W

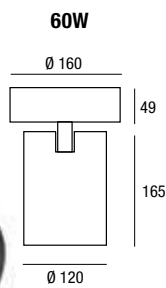
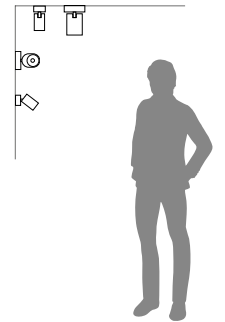
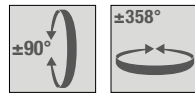
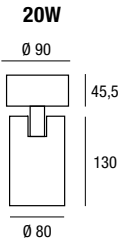

	colour	W	lm output	K	↕	↕ on demand	pcs	Kg	CELL
	B	20	2000	3000	40°	24°	001	1,40	32924/20
	B	20	2000	4000	40°	24°	001	1,40	32924/20/4K
	N	20	2000	4000	40°	24°	001	1,40	32925/20/4K
	B	60	6000	3000	40°	24°	001	1,55	32924/60
	B	60	6000	4000	40°	24°	001	1,55	32924/60/4K
	N	60	6000	3000	40°	24°	001	1,55	32935/60

### LED Primadonna Meat & Vegetables



# LED Camilla C



Apparecchi da soffitto a base cilindrica, ideali per spazi commerciali (grandi magazzini, retail) alberghi e dove è necessaria una illuminazione d'accento.

Driver incorporato e sorgenti luminose comprese.

**Installazione:** a soffitto

**Corpo:** alluminio pressofuso. Verniciatura di tipo poliester e eseguita a polvere.

**Conforme alla norma:** EN60598-1, RG0 nessun rischio fotobiologico ai fini della norma EN62471.

**LED:** mantenimento del flusso luminoso minimo al 80%: L80B20>50.000h.

*Ceiling luminaires with a cylindrical base, ideal for commercial spaces (department stores, retail), hotels and where accent lighting is required.*

*Built-in driver and light sources included.*

**Installation:** ceiling

**Body:** die-cast aluminum. Powder coated polyester type.

**Compliant with standard:** EN60598-1, RG0 no photobiological risk for the purposes of standard EN62471.

**LED:** minimum luminous flux maintenance at 80%: L80B20>50.000h.

## LED Camilla C

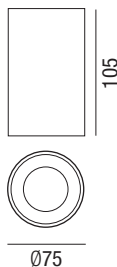

220 240V	50/60 Hz	IK07	IP44	CRI 90	+40 C° -20	850°
CE			DRIVER INCLUDED	RG0	FLICKER FREE	

Color	W max	Light Source	Lm Output	Beam Angle	K	pcs	Kg	CELL
B	7	Led GU10	700	36°	3000	001	0,300	CAM49W7W3K
B	7	Led GU10	700	36°	4000	001	0,300	CAM49W7W4K
N	7	Led GU10	700	36°	3000	001	0,300	CAM49B7W3K
N	7	Led GU10	700	36°	4000	001	0,300	CAM49B7W4K

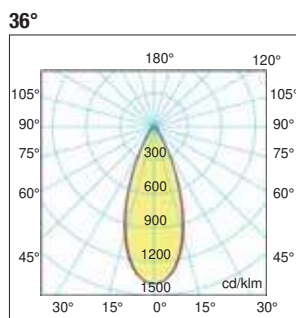

# LED Dolcetondo C

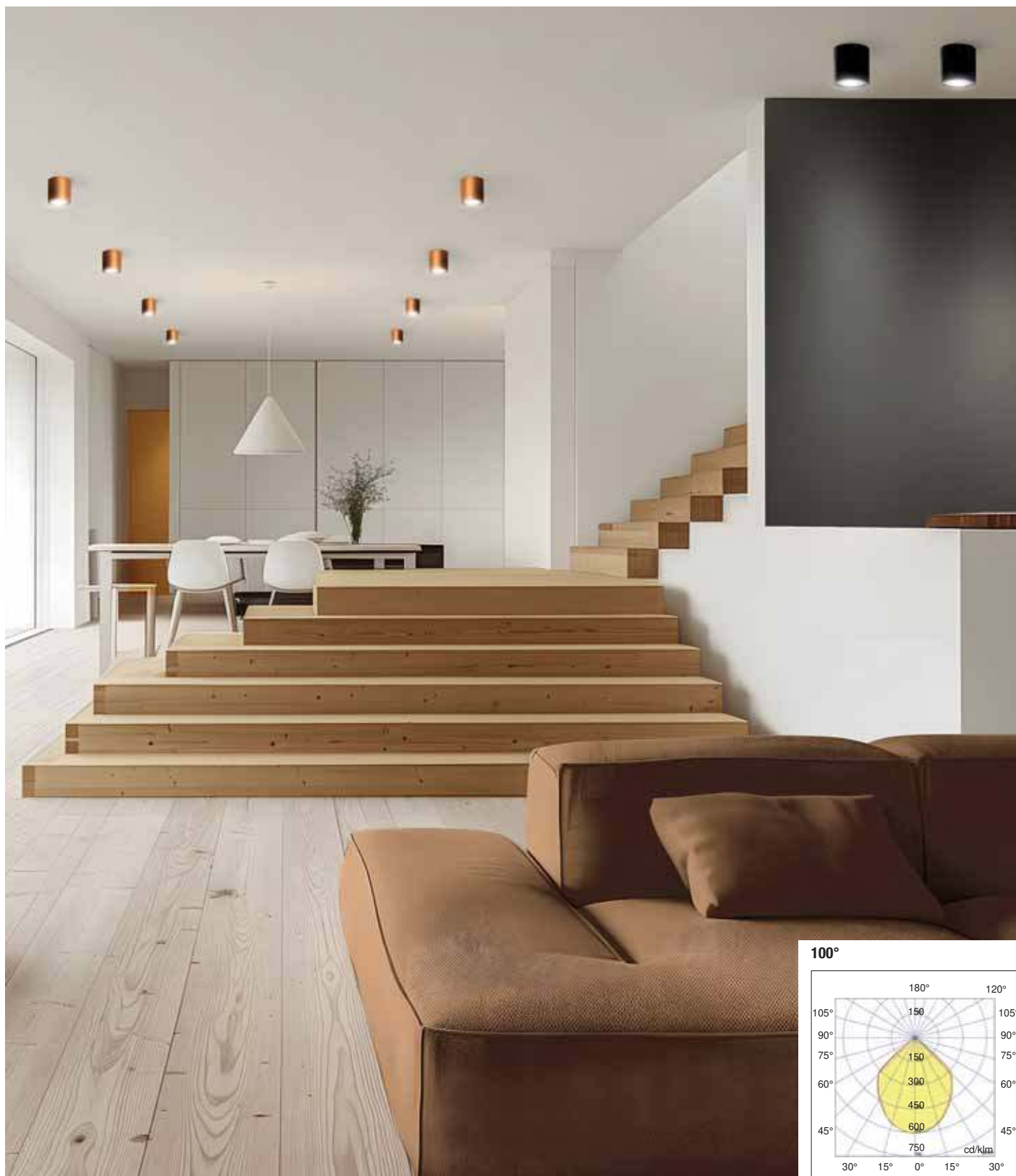

Apparecchi da soffitto a base cilindrica, ideali per spazi commerciali (grandi magazzini, retail) alberghi e dove è necessaria una illuminazione d'accento.

Driver incorporato e sorgenti luminose comprese.

**Installazione:** a soffitto

**Corpo:** alluminio pressofuso. Verniciatura di tipo poliestere eseguita a polvere, nero RAL 9005 o Bianco RAL 9010.

**Schermo:** in vetro opale.

**Conforme alla norma:** EN60598-1, RG0 nessun rischio fotobiologico ai fini della norma EN62471.

**LED:** mantenimento del flusso luminoso minimo al 80%: L80B20>50.000h.

**Prodotto conforme alle direttive:** 

*Ceiling luminaires with a cylindrical base, ideal for commercial spaces (department stores, retail), hotels and where accent lighting is required.*

*Built-in driver and light sources included.*

**Installation:** ceiling

**Body:** die-cast aluminum. Powder coated polyester type, black RAL 9005 or White RAL 9010.

**Screen:** in opal glass.

**Compliant with standard:** EN60598-1, RG0 no photobiological risk for the purposes of standard EN62471.

**LED:** minimum luminous flux maintenance at 80%: L80B20>50.000h.

**Product compliant with directives:** 

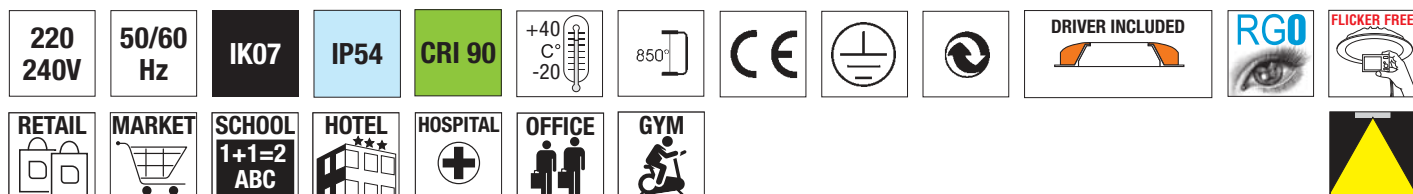

## LED Dolcetondo C

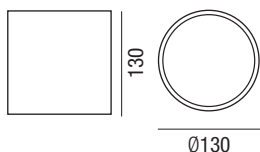

	Color	W	K	pcs	Kg	CELL
	B	10-13-16-19	21 25-28	2700	001	0,400 DOLCE27K28
	B	10-13-16-19	21 25-28	3000	001	0,400 DOLCE3K28
	B	10-13-16-19	21 25-28	4000	001	0,400 DOLCE4K28
	N	10-13-16-19	21 25-28	2700	001	0,400 DOLCE27K28B
	N	10-13-16-19	21 25-28	3000	001	0,400 DOLCE3K28B
	N	10-13-16-19	21 25-28	4000	001	0,400 DOLCE4K28B
	BR	10-13-16-19	21 25-28	2700	001	0,400 DOLCE27K28BR
	BR	10-13-16-19	21 25-28	3000	001	0,400 DOLCE3K28BR
	BR	10-13-16-19	21 25-28	4000	001	0,400 DOLCE4K28BR
	B	10-13-16-19	21 25-28	2700	001	0,400 DOLCE27K28DA
	B	10-13-16-19	21 25-28	3000	001	0,400 DOLCE3K28DA
	B	10-13-16-19	21 25-28	4000	001	0,400 DOLCE4K28DA
	N	10-13-16-19	21 25-28	2700	001	0,400 DOLCE27K28BDA
	N	10-13-16-19	21 25-28	3000	001	0,400 DOLCE3K28BDA
	N	10-13-16-19	21 25-28	4000	001	0,400 DOLCE4K28BDA
	BR	10-13-16-19	21 25-28	2700	001	0,400 DOLCE27K28BRD
	BR	10-13-16-19	21 25-28	3000	001	0,400 DOLCE3K28BRDA
	BR	10-13-16-19	21 25-28	4000	001	0,400 DOLCE4K28BRDA



### Tabella di scelta potenza driver LED - LED Power supply table choice



Fornito di dip switch per la selezione della corrente in uscita. Il driver incluso nel prodotto ha una taratura di fabbrica (vedere tabella). Se necessario è possibile diminuire o aumentare la potenza (vedi foglio istruzioni).

**Equipped with dip switch for selecting the current output.** The driver included inside the product have a driver standard factory setting (see table). If necessary, it is possible to decrease or increase the power (see instruction sheet).

Taratura Dip-switch	Potenza Power	Lm Output
mA	Watt	Lm
400	10	1100
500	13	1430
600	16	1760
700	19	2090
800	21	2300
950	25	2650
1050	28	3000

Taratura standard di fabbrica  
Driver Standard factory setting



**applicazione rapida**  
**quick application**

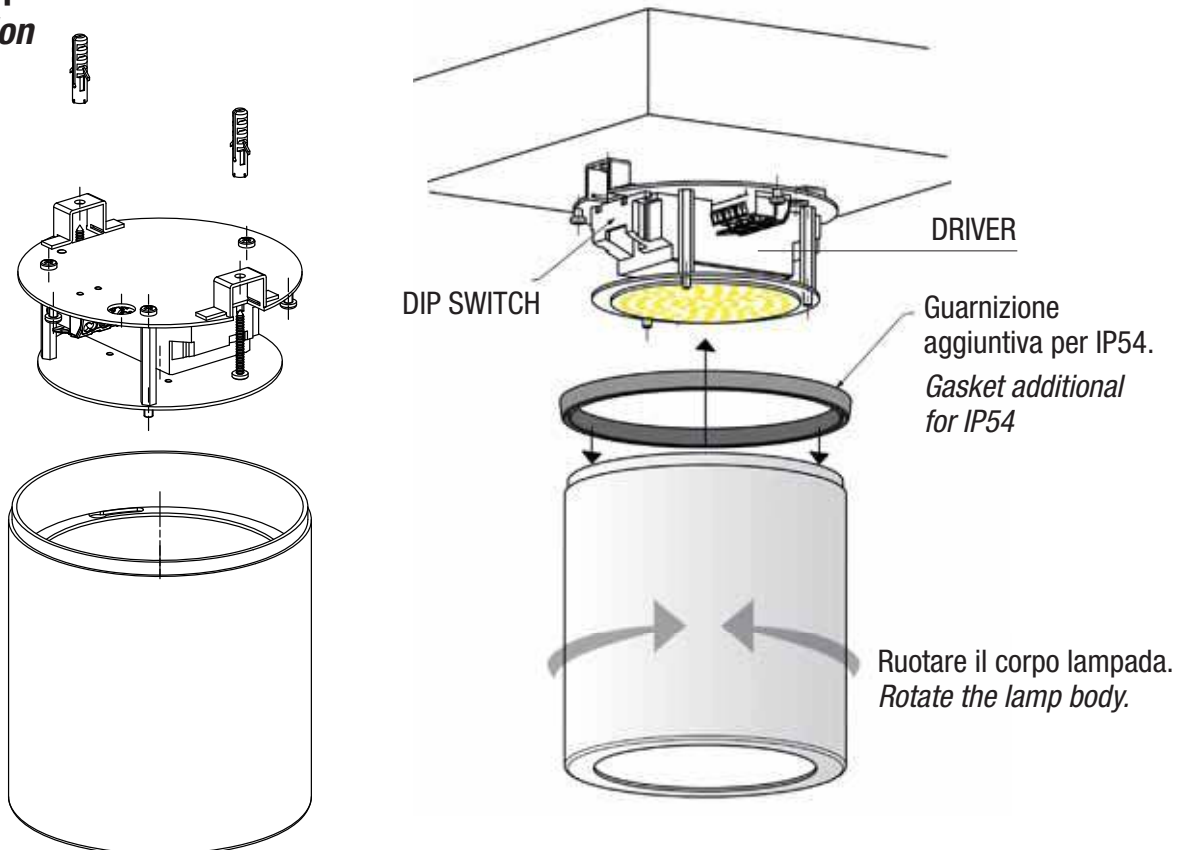

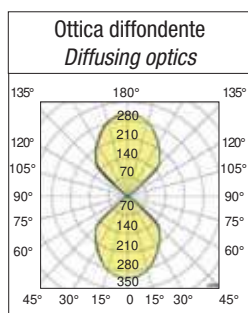

### Colori a richiesta - Colors on request



Versioni colori Bronzo, oro satinato, grigio RAL 9006, sovrapprezzo 30% tempo di consegna 45gg.  
Bronze, satin gold, RAL 9006 grey versions 30% extra charge. Delivery time 45 days.

Apparecchio di illuminazione a led per installazione fissa a parete che trova la propria corretta applicazione in locali dove è richiesto un punto a luce diffusa verso l'alto, verso il basso oppure in entrambe le direzioni. Il design minimale e discreto lo rende adatto ad ogni ambiente. Grazie ad un semplice cut off meccanico posto sul corpo della lampada, è possibile la regolazione angolare del fascio luminoso emesso.

**Installazione:** a parete (completo di basetta di fissaggio).

**Corpo:** in alluminio pressofuso UNI 5076, verniciato con polvere termoindurente poliestere.

**Verniciatura:** di tipo poliestere eseguita a polvere. Colore nero RAL 9005, Bianco RAL 9010.

**Verniciatura a richiesta:** colori, bronzo RAL 8028, oro satinato, e grigio RAL 9006.

**Ottica:** diffondente.

**Schermo:** vetro temperato di spessore 3mm.

**Driver:** incorporato.

**Conforme alla norma:** EN60598-1, RG0 nessun rischio fotobiologico ai fini della norma EN62471.

*LED lighting fixture for fixed wall installation that finds its correct application in rooms where a point of diffused light upwards, downwards or in both directions is required.*

*The minimal and discreet design makes it suitable for any environment.*

*Thanks to a simple mechanical cut-off placed on the body of the lamp, it is possible to adjust the angle of the emitted light beam.*

**Installation:** on the wall (complete with fixing base).

**Body:** in die-cast aluminum UNI 5076, painted with thermosetting polyester powder.

**Coating:** polyester powder type. Black RAL 9005, White RAL 9010.

**Coating on request:** bronze RAL 8028, satin gold or gray RAL 9006.

**Optic:** wide beam.

**Screen:** 3mm thick tempered glass.

**Driver:** built-in.

**Compliant with standard:** EN60598-1, RG0 no photobiological risk for the purposes of standard EN62471.

### Orientabilità - Adjustability





wall

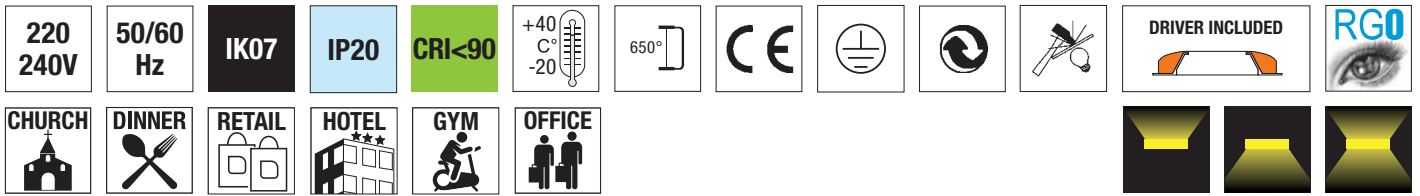

### LED Mini Pop W

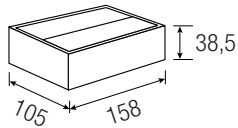

	colour	W	lm output	K	Lm/W	pcs	Kg	CELL
	B	9	1400	3000	157	001	1,50	558116-3KB
<b>DALI 2</b> PUSH	B	9	1400	3000	157	001	1,50	558116-3KBDA
	B	9	1400	4000	157	001	1,50	558116-4KB
<b>DALI 2</b> PUSH	B	9	1400	4000	157	001	1,50	558116-4KBDA
	N	9	1400	3000	157	001	1,50	558116-3KN
<b>DALI 2</b> PUSH	N	9	1400	3000	157	001	1,50	558116-3KNDA
	N	9	1400	4000	157	001	1,50	558116-4KN
<b>DALI 2</b> PUSH	N	9	1400	4000	157	001	1,50	558116-4KNDA

### LED Pop W

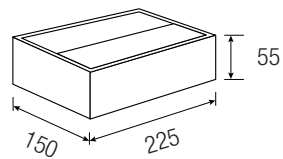

	colour	W	lm output	K	Lm/W	pcs	Kg	CELL
	B	18	2800	3000	157	001	1,50	558117-3KB
<b>DALI 2</b> PUSH	B	18	2800	3000	157	001	1,50	558117-3KBDA
	B	18	2800	4000	157	001	1,50	558117-4KB
<b>DALI 2</b> PUSH	B	18	2800	4000	157	001	1,50	558117-4KBDA
	N	18	2800	3000	157	001	1,50	558117-3KN
<b>DALI 2</b> PUSH	N	18	2800	3000	157	001	1,50	558117-3KNDA
	N	18	2800	4000	157	001	1,50	558117-4KN
<b>DALI 2</b> PUSH	N	18	2800	4000	157	001	1,50	558117-4KNDA

### LED Pop double W

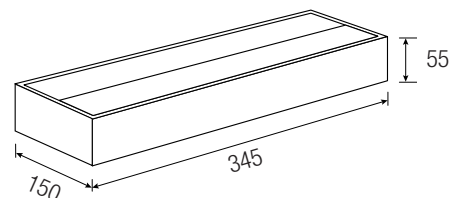

	colour	W	lm output	K	Lm/W	pcs	Kg	CELL
	B	36	5600	3000	157	001	3,00	558118-3KB
<b>DALI 2</b> PUSH	B	36	5600	3000	157	001	3,00	558118-3KBDA
	B	36	5600	4000	157	001	3,00	558118-4KB
<b>DALI 2</b> PUSH	B	36	5600	4000	157	001	3,00	558118-4KBDA
	N	36	5600	3000	157	001	3,00	558118-3KN
<b>DALI 2</b> PUSH	N	36	5600	3000	157	001	3,00	558118-3KNDA
	N	36	5600	4000	157	001	3,00	558118-4KN
<b>DALI 2</b> PUSH	N	36	5600	4000	157	001	3,00	558118-4KNDA

220  
240V

50/60  
Hz

IK07

IP20

CRI<90

+40  
C  
-20

650°

CE

⊕

↻

✂

DRIVER INCLUDED

RG0

### LED Pop WD

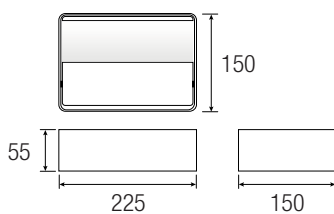

colour	W	lm output	K	Lm/W	pcs	Kg	CELL
B	18	2800	3000	157	001	1,50	558119-3KB
B	18	2800	4000	157	001	1,50	558119-4KB
N	18	2800	3000	157	001	1,50	558119-3KN
N	18	2800	4000	157	001	1,50	558119-4KN

### LED Pop double WD

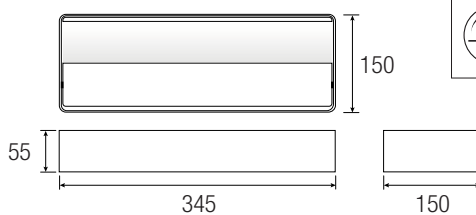

colour	W	lm output	K	Lm/W	pcs	Kg	CELL
B	36	5600	3000	157	001	3,00	558120-3KB
B	36	5600	4000	157	001	3,00	558120-4KB
N	36	5600	3000	157	001	3,00	558120-3KN
N	36	5600	4000	157	001	3,00	558120-4KN

Pop a parete con cavo, driver a spina e regolazione incorporata.  
Wall-mounted pop with plug-in driver and built-in regulation.

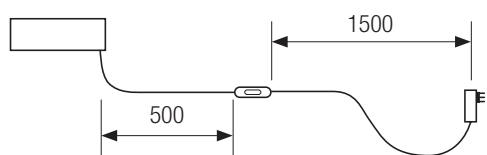

wall

# LED Lineasu W

CON ILLUMINAZIONE INDIRECTA  
WITH INDIRECT LIGHTING



Apparecchio di illuminazione a led da interno per installazione fissa a parete che trova la propria corretta applicazione in corridoi o locali dove è richiesto un punto luce discreto con emissione diffusa solo verso l'alto. La limitata sporgenza dal muro e le basse temperature superficiali consentono, dove fosse necessario, installazioni anche ad altezze ridotte.

**Corpo:** in lastra di alluminio tagliata, piegata e lavorata meccanicamente, spessore 10mm. attacco a parete in metallo piegato.

**Verniciatura:** bianco RAL 9010, nero RAL 9005 con verniciatura a polvere e finitura superficiale gofrata. Bronzo antico RAL8028, e Oro (a richiesta) con verniciatura a polvere e finitura superficiale liscia.

**Ottica:** semi-diffondente.

**Schermo:** diffusore in policarbonato opalino.

**Driver:** incorporato.

**Conforme alla norma:** EN60598-1, RG0 nessun rischio fotobiologico ai fini della norma EN62471.

*Indoor LED lighting fixture for fixed wall installation that finds its correct application in corridors or rooms where a discrete light point is required with diffused emission only upwards. The limited protrusion from the wall and the low surface temperatures allow, where necessary, installations even at reduced heights.*

**Body:** made of cut, folded and mechanically machined aluminium sheet, 10mm thick. Wall attachment in folded metal.

**Painting:** white RAL 9010, black RAL 9005 with powder coating and embossed surface finish.

*Antique bronze RAL8028, and Gold (on request) with powder coating and smooth surface finish.*

**Optics:** semi-diffusion.

**Screen:** opal polycarbonate diffuser.

**Driver:** built-in.

**Complies with the standard:** EN60598-1, RG0 no photobiological risk for the purposes of the EN62471 standard.

A RICHIESTA Colore Bronzo e Oro - ON REQUEST Bronze and Gold Color



Aggiungere dopo il codice OR - BR;  
esempio LINE1327KBBR.

Add after the OR code - BR;  
example LINE1327KBBR

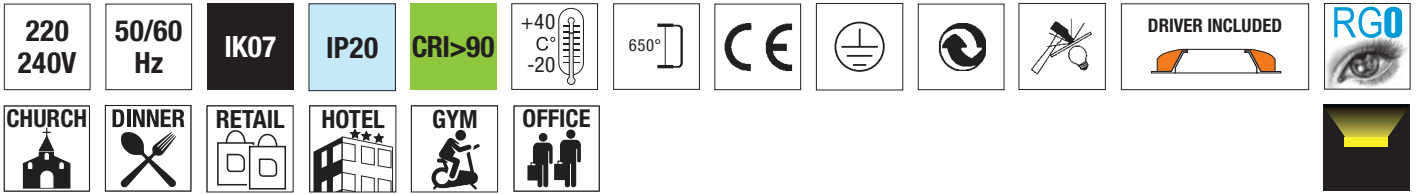

**LED Lineasu W**

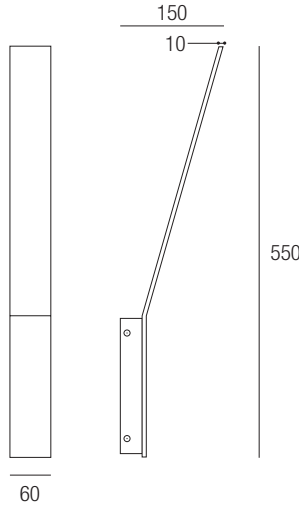

	colour	W	lm output	K	Lm/W	pcs	Kg	CELL
	B	13	1300	2700	100	001	0,70	LINE1327KB
	B	13	1300	3000	100	001	0,70	LINE133KB
	B	13	1300	4000	100	001	0,70	LINE134KB
	DALI 2 PUSH B	13	1300	2700	100	001	0,70	LINE1327KBDA
	DALI 2 PUSH B	13	1300	3000	100	001	0,70	LINE133KBDA
	DALI 2 PUSH B	13	1300	4000	100	001	0,70	LINE134KBDA
	N	13	1300	2700	100	001	0,70	LINE1327KN
	N	13	1300	3000	100	001	0,70	LINE133KN
	N	13	1300	4000	100	001	0,70	LINE134KN
	DALI 2 PUSH N	13	1300	2700	100	001	0,70	LINE1327KNDA
	DALI 2 PUSH N	13	1300	3000	100	001	0,70	LINE133KNDA
	DALI 2 PUSH N	13	1300	4000	100	001	0,70	LINE134KNDA
	B	18	1800	2700	100	001	0,70	LINE1827KB
	B	18	1800	3000	100	001	0,70	LINE183KB
	B	18	1800	4000	100	001	0,70	LINE184KB
	DALI 2 PUSH B	18	1800	2700	100	001	0,70	LINE1827KBDA
	DALI 2 PUSH B	18	1800	3000	100	001	0,70	LINE183KBDA
	DALI 2 PUSH B	18	1800	4000	100	001	0,70	LINE184KBDA
	N	18	1800	2700	100	001	0,70	LINE1827KN
	N	18	1800	3000	100	001	0,70	LINE183KN
	N	18	1800	4000	100	001	0,70	LINE184KN
	DALI 2 PUSH N	18	1800	2700	100	001	0,70	LINE1827KNDA
	DALI 2 PUSH N	18	1800	3000	100	001	0,70	LINE183KNDA
	DALI 2 PUSH N	18	1800	4000	100	001	0,70	LINE184KNDA

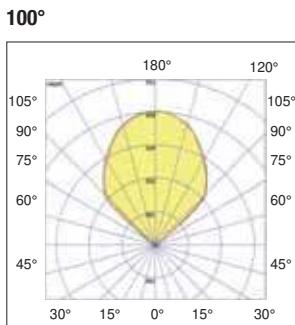

wall

# Gesso ceramico W

## Lampade in gesso - *Ceramic plaster lighting*



Plaster applique

Serie di applique in gesso a forma di mezza luna o rettangolari con vetro satinato e duplice diffusione della luce.

Il fascio luminoso bidirezionale di questi modelli crea incantevoli effetti scenici, concedendo ampia libertà progettuale.

Prodotti versatili, dal design essenziale, verniciabili, semplici da coordinare ed integrare agli interni in base alle necessità progettuali e ai gusti personali.

Complete di portalamпада E27.

*Series of half moon or rectangular wall lamps in plaster with frosted glass and double light diffusion.*

*The bidirectional light beam of these models creates enchanting scenic effects, allowing ample design freedom.*

*Versatile products, with an essential design, easy to paint, easy to coordinate and integrate with the interiors according to the design needs and personal tastes.*

*Complete with E27 lamp holder.*

220  
240V

50/60  
Hz

IK07

IP20

+40  
C°  
-20

650°

CE



### Gipsy Mezzaluna 35

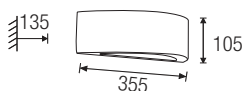

colour		pcs	Kg	S
B	E27	001	1,50	2410/N

### Gipsy Mezzaluna 60

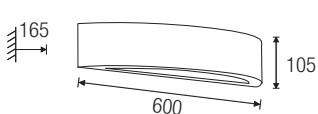

colour		pcs	Kg	S
B	2XE27	001	2,00	2411

### Gipsy Mezzaluna 60

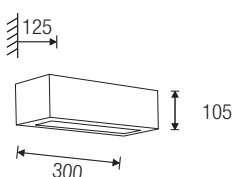

colour		pcs	Kg	S
B	E27	001	2,00	2206

### Gipsy Rettangolare 70

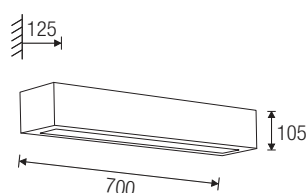
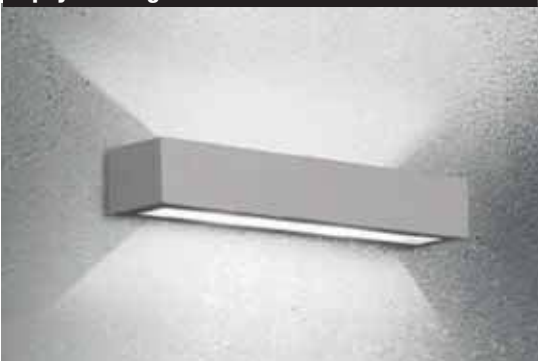

colour		pcs	Kg	S
B	2XE27	001	3,00	2208

Plaster applique

# LED Huitre W - 2CCT



220 240V	50/60 Hz	IK06	IP20	CRI<90	+45 C -20	850°	CE				DRIVER INCLUDED	RG0
CHURCH	DINNER	RETAIL	MARKET	HOTEL	GYM							



LED Huitre è una lampada da parete up & down di forma ovale per interni con driver integrato.

**Sorgente:** LED SMD ad alta luminosità.

**Corpo:** in alluminio ADC12 che offre un'ottima gestione termica.

**Verniciatura:** Nero RAL 9005.

**Riflettore:** il riflettore per PC può essere personalizzato in diversi colori (il colore standard è bianco).

È disponibile un CCT intercambiabile con interruttore a scorrimento.

*LED Huitre is an oval-shaped up & down wall lamp for interiors with integrated driver.*

**Source:** high lumen SMD LED.

**Body:** in ADC12 aluminum which offers excellent thermal management.

**Paint:** Black RAL 9005.

**Reflector:** PC reflector can be customized in different colors (standard color is white).

An interchangeable CCT with slide switch is available.

## LED Huitre W

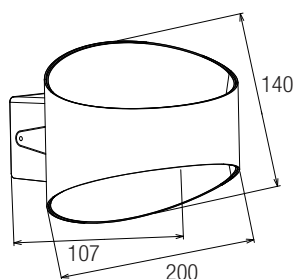

Funzione 2 CCT (3000K - 4000K) modificabile con interruttore a cursore  
Slide switch 2 CCT (3000K - 4000K) changeable function



Regolabile con dimmer a TRIAC  
Dimmable with TRIAC dimmer

colour	W	Optic	Lm	K	pcs	Kg	CELL	
N	8W	360°	425	3000	4000	1	0,52	RL95-8W-BL2P

# LED Rouget W

220 240V	50/60 Hz	IK07	IP20	CRI<90	+45 C -20	750°	CE				DRIVER INCLUDED	RG0
CHURCH	DINNER	RETAIL	MARKET	HOTEL	GYM							



Appliche ad illuminazione soffusa diretta/indiretta, con base rotante che consente di ruotare il corpo illuminante sull'asse orizzontale e verticale per creare suggestivi effetti di luce.

**Corpo lampada:** in alluminio ADC12. Ruotabile di 350° orizzontalmente

**Cover:** in policarbonato. Ruotabile di 28° verticalmente

**Verniciatura:** Bianco RAL 9016

**Installazione:** a plafone o parete

*Wall lamp with direct/indirect soft lighting, with rotating base that allows you to rotate the lighting body on the horizontal and vertical axis to create suggestive light effects.*

***Lamp body:** in aluminum ADC12. 350 ° rotatable horizontally*

***Cover:** in polycarbonate. Can be rotated by 28 ° vertically*

***Paint:** White RAL 9016*

***Installation:** ceiling or wall*



## LED Rouget W

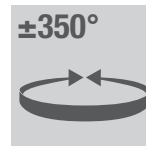
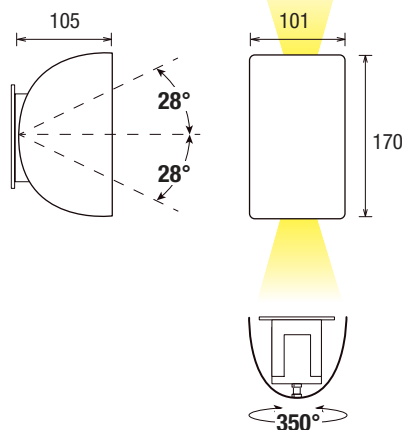

colour	W	Optic	Lm	K	pcs	Kg	CELL
B	2x4	90°	640	3000	1	0,68	RL101-8W-WH3K

# LED Rhombe 3CCT

**NEW**



200 240V	50/60 Hz	IK06	IP40	CRI 85	+45 C° -20	750°	CE		
DINNER	RETAIL	MARKET	SCHOOL 1+1=2 ABC	HOTEL	HOSPITAL	OFFICE	GYM	Dimmerabile Dimmable Triac IGBT	

DRIVER INCLUDED	RG0



Plafoniera a doppia fonte luminosa a Led integrato 3CCT, design minimal e moderno che si adatta a qualsiasi ambiente. Una lampada di facile installazione sia a soffitto a parete che sospesa grazie agli accessori (da ordinare a parte) estremamente versatile e dalla forma semplice, tonda, minimal. Collocabile sia in contesti privati, nel vostro ingresso, corridoio, soggiorno, sia in contesti lavorativi (studi, uffici) che commerciali (negozi di vario genere), l'ampiezza del fascio di luce generato illumina in maniera uniforme riducendo le ombre o le zone di penombra.

**Corpo lampada e diffusore:** in policarbonato.  
**Dimmerazione:** dimmerabile mediante varialuce a Triac.  
**Temperatura colore:** CCT intercambiabile (3000K+4000K+5700K) con interruttore a scorrimento.  
**Verniciatura:** Bianco RAL 9016.  
**Installazione:** a soffitto, parete, sospensione tramite gli accessori (da ordinare a parte).  
**Driver:** incorporato.  
**Conforme alla norma:** EN60598-1, RG0 nessun rischio fotobiologico ai fini della norma EN62471.

*Ceiling lamp with double light source with integrated LED 3CCT, minimal and modern design that adapts to any environment.*

*An easy-to-install lamp both on the ceiling, on the wall and suspended thanks to the accessories (to be ordered separately) extremely versatile and with a simple, round, minimal shape. Placeable both in private contexts, in your entrance, corridor, living room, and in work contexts (studies, offices) and commercial (stores of various kinds), the width of the light beam generated illuminates uniformly reducing shadows or areas of darkness.*

**Lamp body and diffuser:** in polycarbonate.  
**Dimming:** dimmable with Triac dimmer.  
**Color Temperature:** Interchangeable CCT(3000K+4000K+5700K) with slide switch.  
**Paint:** White RAL 9016.  
**Installation:** ceiling, wall or suspended (with accessories (to be ordered separately)).  
**Driver:** built-in.  
**Compliant with standard:** EN60598-1, RG0 no photobiological risk for the purposes of standard EN62471.



3000K - warm light



5700K - cold light

## LED Rhombe 3CCT

**3in1**

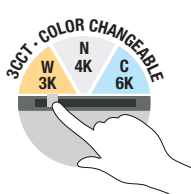
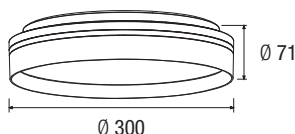

colour	W max	△	lm output	K	pcs	Kg	CELL
B	20	110°	max 2300	3000 4000 5700	001	0.60	RE181-12-20W



**Accessori non inclusi - not included accessories**



**Cod. ACAL149WT0200**  
 Kit sospensione  
 Suspension kit

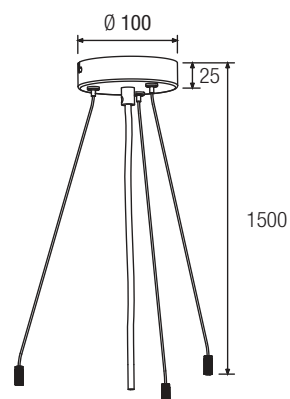

# LED COQUILLE UP & DOWN 3CCT

**NEW**

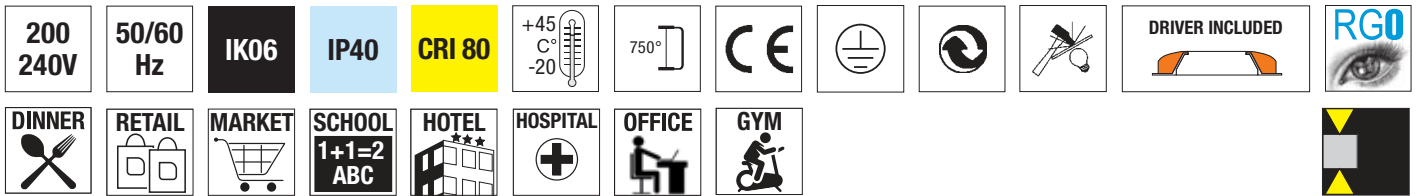

4000K - neutral light

Applique moderna ad illuminazione soffusa diretta e indiretta con corpo in alluminio ADC12 che offre un'ottima gestione termica, l'ottica con angolo del fascio luminoso ampio a 120 gradi dona un'illuminazione diffusa e confortevole.

**Corpo lampada:** in alluminio ADC12.

**Diffusore:** in policarbonato opale.

**Temperatura colore:** CCT intercambiabile (3000K+4000K+5700K) con interruttore a scorrimento.

**Verniciatura:** Bianco RAL 9016.

**Installazione:** a parete.

**Driver:** incorporato.

**Conforme alla norma:** EN60598-1, RGO nessun rischio fotobiologico ai fini della norma EN62471.

*Modern wall lamp with direct and indirect soft lighting with body in ADC12 aluminum which offers excellent thermal management, the optics with a wide 120 degree light beam angle give diffused and comfortable lighting.*

**Lamp body:** in aluminum ADC12.

**Diffuser:** in opal polycarbonate

**Temperatura colore:** Interchangeable CCT(3000K+4000K+5700K) with slide switch.

**Paint:** White RAL 9016.

**Installation:** ceiling or wall.

**Driver:** built-in.

**Compliant with standard:** EN60598-1, RGO no photobiological risk for the purposes of standard EN62471.



3000K - warm light



5700K - cold light

## LED COQUILLE UP & DOWN 3CCT



**3 in 1**

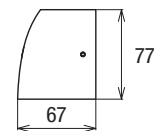
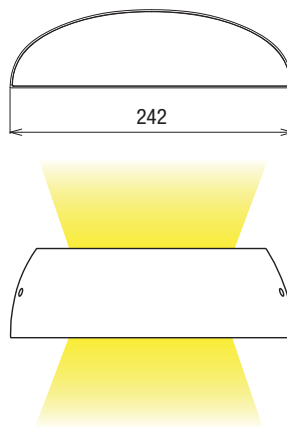
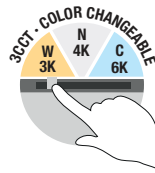

colour	W max	Beam angle	lm output	K	pcs	Kg	S+L
[B]	8	120° up&down	max 770	3000 4000 5700	001	0.60	RL102-8W-C3



# Sovraspecchio LED IP54 3CCT



110 240V	50/60 Hz	IK07	IP54	CRI 80	+45 C° -20	750°	CE				DRIVER INCLUDED	RG0
DINNER	RETAIL	MARKET	SCHOOL 1+1=2 ABC	HOTEL	HOSPITAL	OFFICE	GYM					



Appliche in alluminio verniciato, con due finiture, bianco o argento, disponibile in due misure 600mm o 900mm, con schermo in policarbonato opale, IP54 con illuminazione a LED integrata 3CCT con possibilità di scelta tra tre diverse temperature di colore, bianco caldo, bianco neutro o bianco freddo, idonea per applicazioni in zone umide, utilizzo ideale come lampada sovrasmiraglio in bagno oppure per l'illuminazione di quadri.

*Aluminium wall lamp painted aluminum, with two finishes, white or silver, available in two sizes 600mm or 900mm, with opal polycarbonate screen, IP54 with integrated 3CCT LED lighting with the possibility of choosing between three different color temperatures, warm white, neutral white or cold white, suitable for applications in humid areas, ideal for use as a lamp above the mirror in the bathroom or for lighting paintings.*

## LED Sovraspecchio 10W

**3in1**

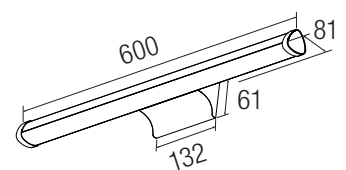
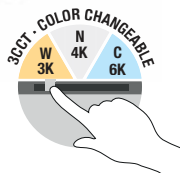

colour	W max	Beam angle	lm output	3000K	4000K	6000K	pcs	Kg	CELL
B	10	110°	max 1143	3000	4000	6000	001	0.60	R-600B10W

Wall



3000K  
Luce calda  
warm light



4000K  
Luce neutra  
Neutral light



6000K  
Luce fredda  
Cold light



**LED Sovraspecchio 15W**

**3in1**

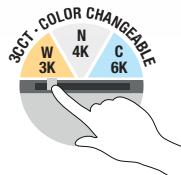
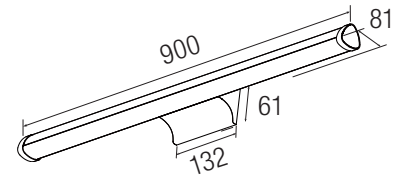

colour	W max		lm output	3000	4000	6000	pcs	Kg	CELL
<b>B</b>	15	110°	max 1790	3000	4000	6000	001	0.80	R-900B-15W

**LED Sovraspecchio 15W**

**3in1**

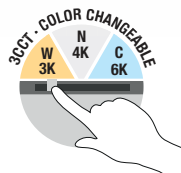
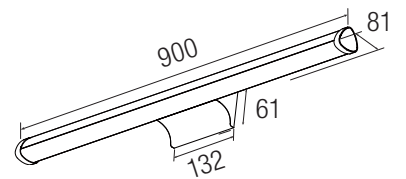

colour	W max		lm output	3000	4000	6000	pcs	Kg	CELL
<b>S</b>	15	110°	max 1790	3000	4000	6000	001	0.80	R-900S-15W

# LED Primadonna S

A RICHIESTA  
ON DEMAND



Proiettori orientabili progettati per illuminare spazi commerciali (supermercati, grandi magazzini, retail, ecc.), uffici e qualsiasi ambiente dove è necessaria un'illuminazione generale e d'accento.

**Installazione:** a sospensione (completo di rosone di fissaggio).

**Corpo:** in alluminio pressofuso UNI 5076, verniciato con polvere termoisolante poliester.

**Verniciatura:** di tipo poliester eseguita a polvere. Colore nero RAL 9005 o Bianco RAL 9010.

**Temperatura colore:** 3000K - 3500K - 4000K (3CCT).

**Ottica:** semi concentrante (a richiesta concentrante).

**Schermo:** vetro temperato di spessore 3mm.

**Driver:** incorporato.

**Conforme alla norma:** EN60598-1, RG0 nessun rischio fotobiologico ai fini della norma EN62471.

**Led:** LUMILEDS - PHILIPS mantenimento del flusso luminoso minimo al 80%: L80B20>50.000h.

*Series of adjustable projectors designed to light up retail spaces (supermarkets, department stores, shops, etc.), offices and any other place that requires general and spot lighting.*

**Installation:** for suspension (complete with ceiling rose).

**Body:** made by UNI 5076 die-cast aluminum, coated with polyester thermoset powder.

**Coating:** coated with powdered polyester. RAL 9005 black or RAL 9010 white color.

**Color temperature:** 3000K - 3500K - 4000K (3CCT).

**Optic:** semi-clumping (clumping on demand).

**Shield:** tempered glass with 3mm thickness.

**Driver:** included.

**According to standard:** EN60598-1, RG0 exempt from photo-biological risks in compliance with standard EN62471.

**Led:** LUMILEDS - PHILIPS maintenance of minimum luminous flux to 80%: L80B20>50.000h.



220 240V	50/60 Hz	IK07	IP20	CRI<90	+40 C° -20	650°	CE				DRIVER INCLUDED	RG0
CHURCH	DINNER	RETAIL	MARKET	HOTEL	GYM	A richiesta: dimmerabile On demand: <i>dimnable</i>						

### LED Primadonna S

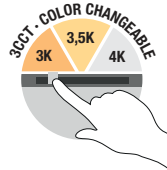
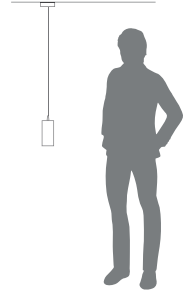
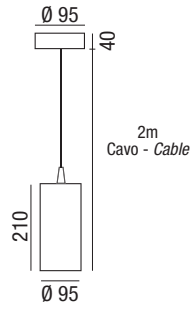

colour	W	lm output	K	△	△ on demand	pcs	Kg	CELL
B	30	3000	3000	40°	24°	001	1,44	32920/30/S
N	30	3000	3000	40°	24°	001	1,44	32922/30/S
B	30	3000	4000	40°	24°	001	1,44	32920/30/S/4K
N	30	3000	4000	40°	24°	001	1,44	32922/30/S/4K
<b>LED Primadonna S - 3CCT <span style="color:red">NEW</span></b>								
B	30	3000	3000 3500 4000	40°	24°	001	1,44	3292030S-3CCT
N	30	3000	3000 3500 4000	40°	24°	001	1,44	3292230S-3CCT



### Accessori non inclusi - Not included accessories

#### Adattatore simmetrico con selettore di fase Symmetrical adapter with phase selector

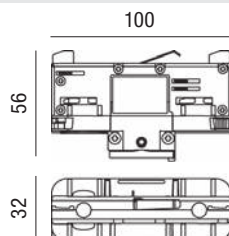

Colour	A	connectors	pcs	Kg	Code
B	max 10Kg	4	010	0,05	9009-4/W
B	max 10Kg	6 DALI	010	0,05	9209/W
B	Nippel per sospensione/ <i>Suspension nipple</i>				S-9009/BC-W
N	max 10Kg	4	010	0,05	9009-4/B
N	max 10Kg	6 DALI	010	0,05	9209/B
N	Nippel per sospensione/ <i>Suspension nipple</i>				S-9009/BC-B

# LED Imperceptible S



Suspended

Lampada a sospensione moderna ad una luce con rosone e diffusore in metallo e finitura in vernice opaca nera o bianca. Disponibile in due misure dal design minimalista ed elegante a forma cilindrica dal diametro di soli tre centimetri. Si adatta perfettamente ad uffici, show room, banconi bar, ambienti museali oppure ad ambienti domestici. Grazie agli accessori multilampada è possibile ottenere una sospensione con 2, 3 o 5 lampade e combinarle a scelta tra le due misure.

**Installazione:** a sospensione (completo di rosone di fissaggio).

**Corpo:** in alluminio pressofuso UNI 5076, verniciato con polvere termoindurente poliestere.

**Verniciatura:** di tipo poliestere eseguita a polvere. Colore nero RAL 9005 o Bianco RAL 9003 (altre colorazioni a richiesta).

**Ottica:** semi concentrante (a richiesta concentrante).

**Schermo:** vetro temperato di spessore 3mm.

**Driver:** ON-OFF incorporato, driver DALI da ordinare separatamente.

**Conforme alla norma:** EN60598-1, RG0 nessun rischio fotobiologico ai fini della norma EN62471.

**Led:** LUMILEDS - PHILIPS 2700K, 3000K o 4000K, mantenimento del flusso luminoso minimo al 80%: L80B20>50.000h.

*Modern single light pendant lamp with rosette and metal diffuser and black or white matt paint finish. Available in two sizes with a minimalist and elegant design in a cylindrical shape with a diameter of just three centimeters. It adapts perfectly to offices, showrooms, bar counters, museum environments or domestic environments. Thanks to the multi-lamp accessories it is possible to obtain a suspension with 2, 3 or 5 lamps and combine them as desired between the two sizes.*

**Installation:** for suspension (complete with ceiling rose).

**Body:** made by UNI 5076 die-cast aluminum, coated with polyester thermoset powder.

**Coating:** coated with powdered polyester. RAL 9005 black or RAL 9003 white color (other colors on request).

**Optic:** semi-clumping (clumping on demand).

**Shield:** tempered glass with 3mm thickness.

**Driver:** Incorporated ON-OFF, DALI driver to be ordered separately.

**According to standard:** EN60598-1, RG0 exempt from photo-biological risks in compliance with standard EN62471.

**Led:** LUMILEDS - PHILIPS 2700K, 3000K o 4000K, maintenance of minimum luminous flux to 80%: L80B20>50.000h.



**Cavo/Cable**  
1600mm. Textile  
2x0,75 mm<sup>2</sup>

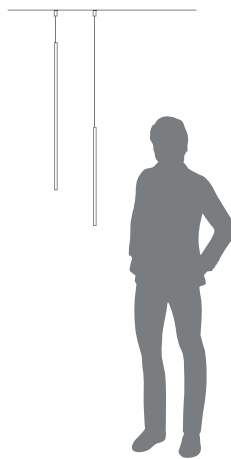

Spot 20°

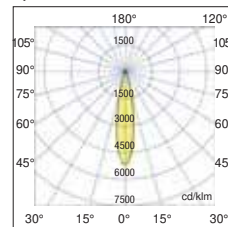

Spot 36° a richiesta  
on request

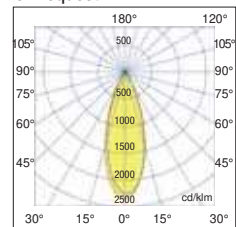

**Accessori non inclusi - Not included accessories**

**Adattatore simmetrico con selettore di fase**  
*Symmetrical adapter with phase selector*

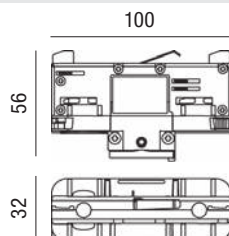

Colour	A	connectors	pcs	Kg	Code
<b>B</b>	max 10Kg	4	010	0,05	9009-4/W
<b>B</b>	max 10Kg	6 DALI	010	0,05	9209/W
<b>B</b>	Nippel per sospensione/ <i>Suspension nipple</i>				S-9009/BC-W
<b>N</b>	max 10Kg	4	010	0,05	9009-4/B
<b>N</b>	max 10Kg	6 DALI	010	0,05	9209/B
<b>N</b>	Nippel per sospensione/ <i>Suspension nipple</i>				S-9009/BC-B

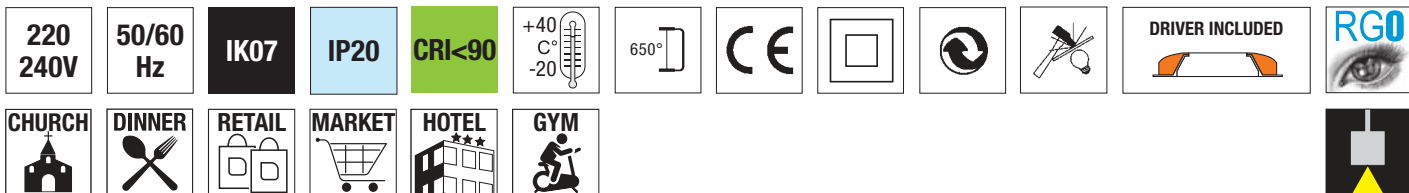

### LED Imperceptible S

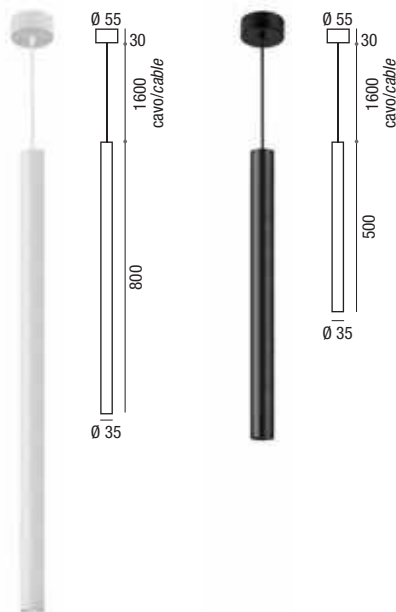

	W max	Lm Output	L mm.	Beam	mA max	K	pcs	Kg	CELL
[B]	10	275	500	20°	700	2700	1	0,05	39002/27KW
<b>DALI 2</b> [B]	10	275	500	20°	700	2700	1	0,05	39002/27KW-DA
[B]	10	275	500	20°	700	3000	1	0,05	39002/3KW
[B]	10	290	500	20°	700	4000	1	0,05	39002/4KW
[N]	10	275	500	20°	700	2700	1	0,05	39002/27KWB
[N]	10	275	500	20°	700	3000	1	0,05	39002/3KWB
[N]	10	290	500	20°	700	4000	1	0,05	39002/4KWB
[B]	10	560	800	20°	700	2700	1	0,05	39001/27KW
<b>DALI 2</b> [B]	10	560	800	20°	700	2700	1	0,05	39001/27KW-DA
[B]	10	560	800	20°	700	3000	1	0,05	39001/3KW
[B]	10	620	800	20°	700	4000	1	0,05	39001/4KW
[N]	10	560	800	20°	700	2700	1	0,05	39001/27KWB
[N]	10	560	800	20°	700	3000	1	0,05	39001/3KWB
[N]	10	620	800	20°	700	4000	1	0,05	39001/4KWB

### Accessori multilampada non inclusi - Multi-lamp accessories not included

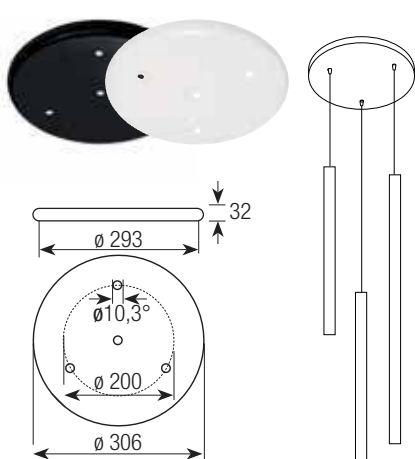

ROSONE TONDO Ø 305 - 4 FORI  
ROUND CEILING ROSE Ø 305 - 4 HOLES

- [B] Bianco/White Cod. ROS/TON/4/B
- [N] Nero/Black Cod. ROS/TON/4/N

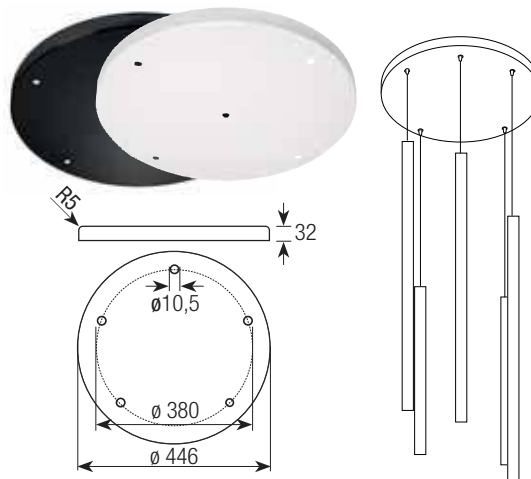

ROSONE TONDO Ø 445 - 5 FORI  
ROUND CEILING ROSE Ø 445 - 5 HOLES

- [B] Bianco/White Cod. ROS/TON/5/B
- [N] Nero/Black Cod. ROS/TON/5/N

Cavo in pvc da ordinare separatamente, rivestito textile 2x0,75mm<sup>2</sup> H03VV lunghezza 5 metri.

PVC cable to be ordered separately, textile coating 2x0.75mm<sup>2</sup> H03VV, 5 meters long.

Color	H mm	Code
[B] Bianco/White	5000	25.346
[N] Nero/Black	5000	25.347

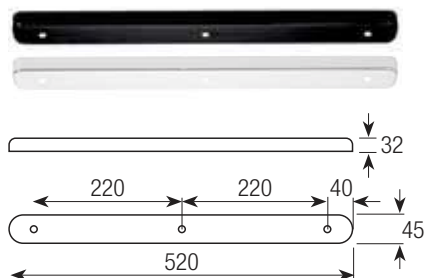

ROSONE RETTANGOLARE 3 FORI  
RECTANGULAR CEILING ROSE - 3 HOLES

- [B] Bianco/White Cod. ROS/RET/3/B
- [N] Nero/Black Cod. ROS/RET/3/N

### Esempio installazione con accessori multilampada Example of installation with multi-lamp accessories





## LED Zante Top S



Apparecchio LED a sospensione ad emissione diretta e indiretta, con selettore 2CCT interno al rosone con il quale è possibile scegliere luce neutra 4000K o luce calda 3000K ad alta resa cromatica, per aree comuni, uffici, corridoi, strutture sanitarie, sale riunioni, negozi. Per ambienti dove sia necessaria una luce diffusa perfettamente omogenea. Ideale per spazi di lavoro in cui è necessario un maggiore controllo dell'abbagliamento, grazie allo schermo diffusore microprismato, abbinato ad uno schermo interno e ad un film diffondente, consente un'ottimale diffusione della componente diretta della luce e un controllo della luminanza  $UGR < 19$ . I led per l'emissione down light e up light sono disposti nel perimetro.

**Installazione:** a sospensione. Il sistema è completo di basetta di alimentazione e cavi lunghezza 2000 mm.

**Corpo e telaio:** profilo perimetrale in alluminio estruso anodizzato, verniciati con polvere termoindurente poliestere.

**Verniciatura:** di tipo poliestere eseguita a polvere. Colore bianco RAL 9010.

**Ottica:** diffusore. Composta da lastra in tecnopolimero (PMMA).

**Schermo:** schermo diffusore microprismato.

**UGR:** Conforme alla norma EN 12464-1 -  $\leq 19$ .

**Temperatura colore:** standard 4000K.

**Conforme alla norma:** EN60598-1, RG0 nessun rischio fotobiologico ai fini della norma EN62471.

**Led:** mantenimento del flusso luminoso minimo al 80%:  $L80B20 > 50.000h$ .

**Driver:** Fattore di potenza  $\geq 0,95$ .

*Suspension LED device with direct and indirect emission, with 2CCT selector inside the ceiling rose, it is possible to choose neutral light 4000K or warm light 3000K with high colour rendering, for public areas, offices, halls, healthcare facilities, meeting rooms, shops. For environments requiring a perfectly evenly diffused light. Ideal for workspaces which need greater glare control, thanks to the microprismatic diffuser screen, coupled to an internal diffusing film screen, for optimal diffusion of the direct light component and luminance control  $UGR < 19$ . LEDs for down light and up light emission are set up in the perimeter.*

**Installation:** suspension. The system includes power baseboard and 2000 mm long cables.

**Body and frame:** perimeter profile in anodised extruded aluminium, coated with thermosetting polyester powder.

**Painting:** powder polyester coating. White RAL 9010.

**Optics:** diffusing. Consisting of techno-polymer sheet (PMMA).

**Screen:** microprismatic diffuser screen.

**UGR:** Complies with standard EN 12464-1 -  $\leq 19$ .

**Colour temperature:** standard 4000K.

**Compliant with standard:** EN60598-1, RG0 no photobiological risk for the purposes mentioned in standard EN62471.

**LED:** maintenance of 80% minimum luminous flux:  $L80B20 > 50.000h$ .

**Driver:** Power factor  $\geq 0.95$ .

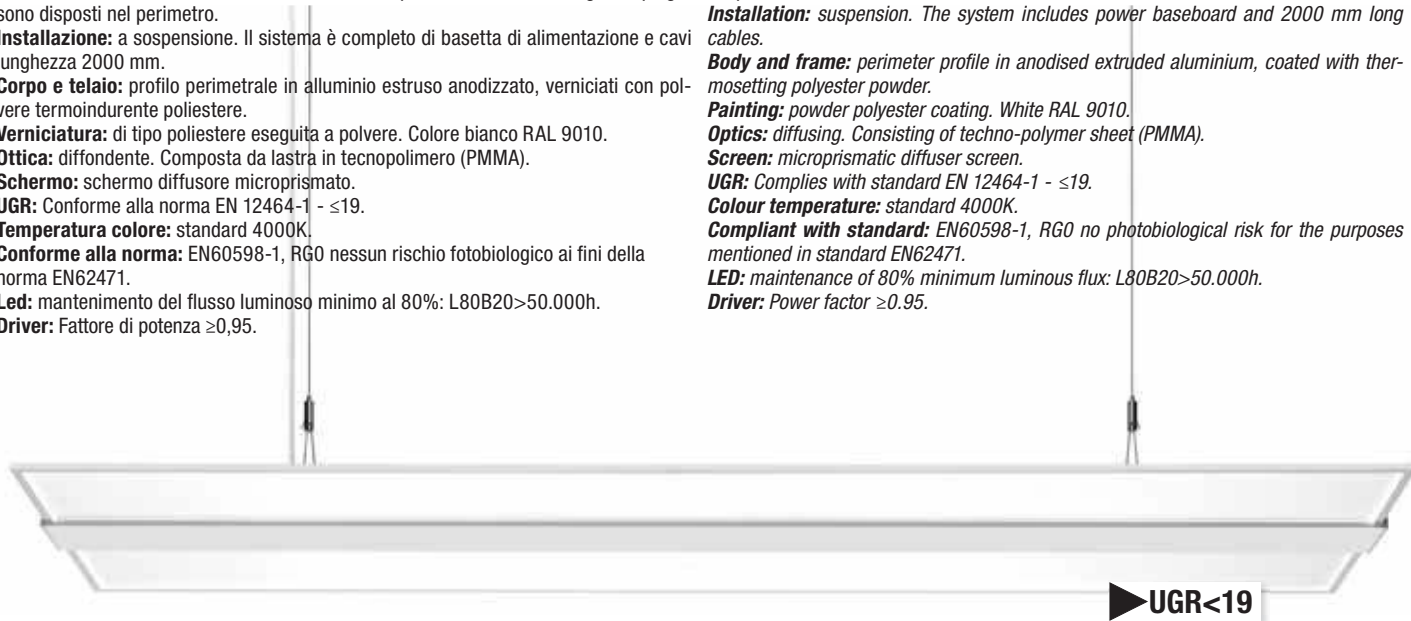

220 240V	50/60 Hz	IK07	IP20	CRI 80	+40 C -20	650°	CE			DRIVER INCLUDED	RG0
RETAIL	MARKET	SCHOOL 1+1=2 ABC	HOTEL	HOSPITAL	OFFICE	GYM	Funzione 2 CCT (3000K - 4000K) modificabile con interruttore a cursore. Slide switch 3 CCT (3000K - 4000K) changeable function.			UGR ≤19	

### LED Zante Top

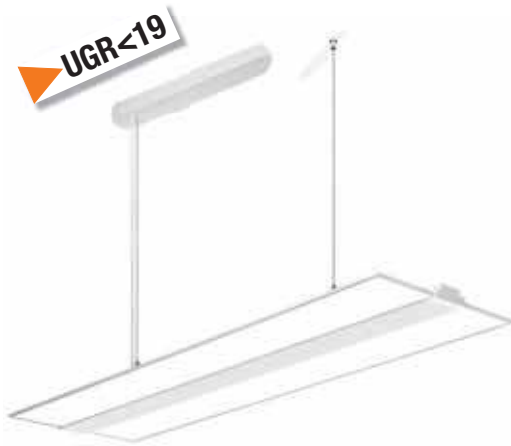

Selettore 2CCT interno al rosone.  
2CCT selector inside the ceiling rose.

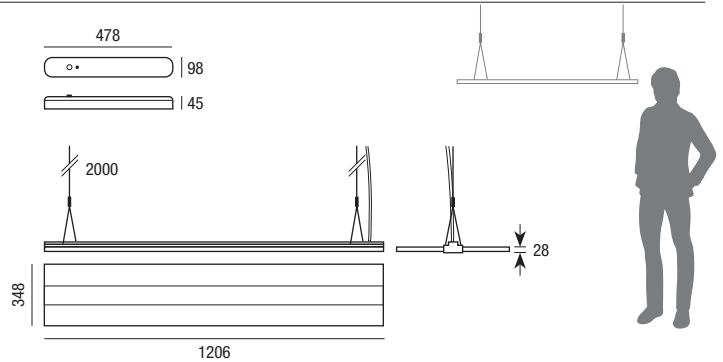

colour	W max	Lm output	lm/W	K	pcs	Kg	CELL
B	45	max 4700	105	3000 4000	001	2,70	25930/S/TOP

**A richiesta:** versione 6000K (consegna 90gg.)  
**On demand:** 6000K versions (delivery 90 days)

**Versione standard:**  
l'apparecchio è predisposto per l'accensione contemporanea di entrambe le emissioni luminose.  
**Standard version:**  
The device is designed for both luminous emissions to switch on simultaneously.

**Sospensione con cavo a Y:**  
il cavo a Y garantisce il perfetto bilanciamento della lampada.  
**Suspension with Y cable:**  
the Y cable guarantees perfect balancing of the lamp.

### Dati fotometrici Photometric data

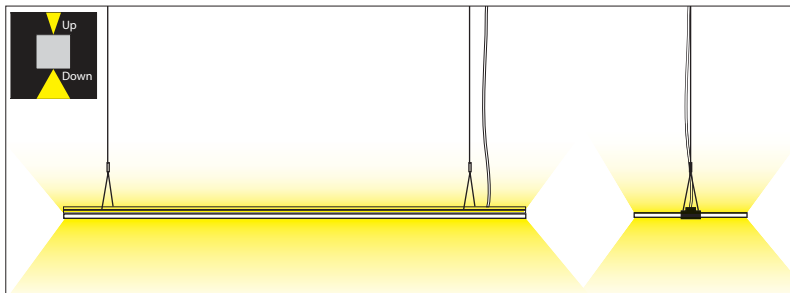
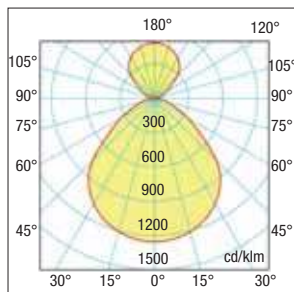

Suspended

# LED Luxxi

A RICHIESTA  
ON DEMAND



Serie di proiettori a sospensione con elevata resa cromatica per utilizzo in centri commerciali, supermercati per mettere in risalto i banchi di alimentari, uffici o spazi in coworking, concessionari e grandi aree in genere.

**Corpo:** vano porta componenti in alluminio pressofuso, verniciato grigio a polveri poliestere resistente alla corrosione ed agli agenti atmosferici. Dissipatore in lega di alluminio estruso. Piastra porta cablaggio in acciaio.

**Diffusore:** in policarbonato trasparente internamente prismaticizzato e all'esterno liscio antipolvere per una rapida pulizia, infrangibile e autoestinguente V2.

**Conforme alla norma:** EN60598-1, RGO nessun rischio fotobiologico ai fini della norma EN62471.

**Led:** mantenimento del flusso luminoso minimo al 80%: L80B20>50.000h.

**Driver:** Incluso > 50.000 h Fattore di potenza ≥0,95.

*Series of suspended projectors with high colour rendering for use in shopping centres, supermarkets to highlight food counters, offices or co-working spaces, dealerships and large areas in general.*

*Body: component holding body in die-cast aluminium with Grey polyester-powder against corrosion and weathering. Dissipator in extruded aluminium alloy. Steel wiring plate.*

*Diffuser: in transparent polycarbonate internally prismaticized and smooth dust-proof on the outside for quick cleaning, unbreakable and self-extinguishing V2.*

*Compliant with standard: EN60598-1, RGO no photobiological risk for the purposes mentioned in standard EN62471.*

**LED:** maintenance of 80% minimum luminous flux: L80B20>50.000h.

**Driver:** Included > 50,000 h Power factor ≥0.95.



220 240V	50/60 Hz	IK08	IP43	CRI 90	+40 C -20	850°	CE			DRIVER INCLUDED	RG0

## LED Luxxi 500

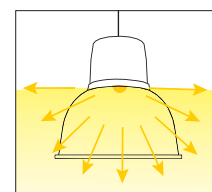
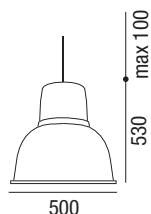

colour	W		Lm output	K	pcs	Kg	CELL
G	40	60°	4600	3000	001	6.50	28161/40W
G	40	60°	4600	4000	001	6.50	28161/4K/40W
G	60	60°	6900	3000	001	6.50	28161/60W
G	60	60°	6900	4000	001	6.50	28161/4K/60W



Suspended

# LED Flex



## LED Flex Monocromatica

Strisce flessibili per interni e per esterni anche in IP20, IP65 o IP67, con led a luce bianca (calda 3000K, neutra 4000K o fredda 6000K).

La versatilità di queste strisce le rende utili in molte applicazioni come ad esempio per disegnare con la luce l'architettura degli edifici, per la retro-illuminazione di espositori o insegne, per banconi o nicchie di negozi, ristoranti, bar, cinema e per effetti scenografici nelle abitazioni.

Le strisce led sono facili da installare, consumano pochissima energia elettrica, e non richiedono manutenzioni.

**Installazione:** tramite ganci in materiale termoplastico (inclusi) o tramite incollaggio.

**Corpo:** materiale termoplastico

**Alimentazione:** 12V, 24V o 48V non inclusa.

**Led:** mantenimento del flusso luminoso minimo al 80%: L90B10>100.000h.

*Flexible LED strips for indoor or outdoor use. Available in IP20, IP65 or IP67 with white (warm 3000K, neutral 4000K or cool 6000K) LEDs.*

*The versatility of these strips means they can be used for various applications: highlighting special architectural features, display stand/sign backlighting, lighting counters/alcoves in shops, restaurants, bars and cinemas and for scenic effects at home.*

*The LED strips are easy to install, consume very little energy, and do not need any maintenance.*

***Installation:** using thermoplastic hooks (included) or an adhesive.*

***Body:** thermoplastic material*

***Power supply:** 12V, 24V or 48V not included.*

***LED:** maintenance of 80% minimum luminous flux: L90B10>100.000h.*

## LED Flex COB

Strisce LED continue flessibili per interni e per esterni in IP20 o IP67, con LED COB a luce bianca (calda 3000K, neutra 4000K).

La versatilità di queste strisce le rende utili in molte applicazioni come ad esempio per disegnare con la luce l'architettura degli edifici, per la retro-illuminazione di espositori o insegne, per banconi o nicchie di negozi, ristoranti, bar, cinema e per effetti scenografici nelle abitazioni.

Le strisce led sono facili da installare, consumano pochissima energia elettrica, durano oltre 50.000 ore e non richiedono manutenzioni.

**Installazione:** tramite ganci in materiale termoplastico (inclusi) o tramite incollaggio.

**Corpo:** materiale termoplastico

**Alimentazione:** 24V non inclusa.

**Led:** mantenimento del flusso luminoso minimo al 80%: L90B10>100.000h.

*Continue and flexible LED COB strips for indoor or outdoor use. Available in IP20 or IP67 with white (warm 3000K, neutral 4000K) LEDs COB.*

*The versatility of these strips means they can be used for various applications: highlighting special architectural features, display stand/sign backlighting, lighting counters/alcoves in shops, restaurants, bars and cinemas and for scenic effects at home.*

*The LED strips are easy to install, consume very little energy, and do not need any maintenance.*

***Installation:** using thermoplastic hooks (included) or an adhesive.*

***Body:** thermoplastic material*

***Power supply:** 24V not included.*

***LED:** maintenance of 80% minimum luminous flux: L90B10>100.000h.*

## LED Flex Tunable white

Strisce flessibili Tunable White con regolazione variabile della temperatura di colore, agendo su un pulsante NA la temperatura colore passa dalla tonalità calda a quella fredda, creano un ambiente capace di sostenere le persone in modo naturale, al pari di quanto fa la luce diurna, per interni e per esterni in IP20 o IP67, con led a luce variabile bianca calda 3000K, neutra 4000K o fredda 6000K. La versatilità di queste strisce le rende utili in molte applicazioni come ad esempio per disegnare con la luce l'architettura degli edifici, per la retro-illuminazione di espositori o insegne, per banconi o nicchie di negozi, ristoranti, bar, e per creare ambienti diversi durante la giornata ricreando la luce esterna, ottima per gli spazi chiusi laddove si necessiti ricreare scenari naturali e aiutare la concentrazione come uffici e aule didattiche.

**Installazione:** tramite ganci in materiale termoplastico (inclusi) o in profili in alluminio dissipanti.

**Corpo:** materiale termoplastico

**Alimentazione:** 12V o 24V non inclusa.

**Led:** mantenimento del flusso luminoso minimo al 80%: L90B10>100.000h.

La striscia può essere collegata insieme ad altre per ottenere file continue di luce (max 10m).

*Flexible Tunable White strips with variable colour temperature adjustment, acting on an NA push button, the colour temperature changes from warm to cold, creating an environment that can support people in a natural way, just like daylight, for indoors and outdoors in IP20 or IP67, with variable warm white light LEDs 3000K, neutral 4000K or cold 6000K. The versatility of these strips makes them useful in many applications, such as to design the architecture of buildings with light, for the backlighting of displays or signs, for counters or niches of shops, restaurants, bars, and to create different environments during the day, recreating the outdoor light, excellent for enclosed spaces where natural scenarios need to be recreated, and help concentration, such as in offices and classrooms.*

***Installation:** using hooks in thermoplastic material (included) or inside dissipating aluminium profiles.*

***Body:** thermoplastic material.*

***Power supply:** 12V or 24V not included.*

***LED:** maintenance of 80% minimum luminous flux: L90B10>100.000h.*

*The strip can be connected together with others to obtain continuous rows of lights (max 10m).*

## LED Neon IP67

Strisce LED siliciche flessibili per esterni in IP67 ma utilizzabili in ambiente interno per creare gole di luce oppure a vista con gli accessori a richiesta, con LED COB a luce bianca (calda 2700K o 3000K).

La versatilità di queste strisce le rende utili in molte applicazioni come ad esempio per disegnare con la luce l'architettura degli edifici, per la retro-illuminazione di espositori o insegne, per banconi o nicchie di negozi, ristoranti, bar, cinema e per effetti scenografici nelle abitazioni.

Le strisce led sono facili da installare, consumano pochissima energia elettrica, durano oltre 50.000 ore e non richiedono manutenzioni.

**Installazione:** tramite ganci in materiale termoplastico (non inclusi) o in profili dissipanti esterni rigidi o flessibili.

**Corpo:** materiale silicico con diametro di piegatura massima:  $\geq 60$  mm.

**Alimentazione:** 24V non inclusa.

**Led:** mantenimento del flusso luminoso minimo al 80%: L90B10>100.000h.

*Flexible silicone LED strips for outdoors in IP67 but can be used indoors to create light*

*coves or exposed with the accessories on request, with white light COB LEDs (warm 2700K or 3000K).*

*The versatility of these strips means they can be used for various applications: highlighting special architectural features, display stand/sign backlighting, lighting counters/alcoves in shops, restaurants, bars and cinemas and for scenic effects at home.*

*The LED strips are easy to install, consume very little energy, and do not need any maintenance.*

***Installation:** via thermoplastic hooks (not included) or in rigid or flexible external dissipating profiles.*

***Body:** silicone material with bending diameter:  $\geq 60$ mm.*

***Power supply:** 24V not included.*

***LED:** maintenance of 80% minimum luminous flux: L90B10>100.000h.*

## DRIVER LED 12V-24V-48V

vedi pag.  
see page

## Controller for Strip LED

vedi pag.  
see page

## LED Flex RGB

vedi pag.  
see page

**ATTENZIONE:** Per le strisce LED in IP20 >4,8W/m e IP67 >15W/m deve essere applicato su un estruso in alluminio o su un opportuno dissipatore che ne permetta l'impiego in un regime di temperatura consono. In particolare la temperatura misurata sul circuito stampato non deve superare i 50°. Ogni applicazione che esuli dal presente accorgimento può compromettere la funzionalità, nonché la vita del prodotto. Relco dispone di estrusi in alluminio o dissipatori in varie dimensioni, in modo da poter esaudire il maggior numero di richieste. **Relco non si assume la responsabilità di tagli effettuati dopo la consegna delle strisce a LED.**

**ATTENTION:** To the LED strips (> 4,8W/m) has to be applied on an aluminium profile or an special heat sink in order to guarantee the product to work properly under controlled temperature. In particular the measured temperature on the pcb must not exceed 50°C. Any other type of application that doesn't follow the previous specs could damage the function and the life of the LED Strip. Relco has aluminium extruded profiles or heat sinks in different dimensions, in order to carry out the greatest number of requests. **Relco does not assume responsibility for cuts made after delivery of the LED strips.**

# LED Flex monocromatica 12Vdc IP20 - IP67

## LED Flex monocromatica 12V.



**CRI 90**

**IP20**



**COMPATIBLE**  
cod. 20072  
cod. 20074



colour	W/m	Led/mt *	Pitch LED	K	Lm/m	Efficiency	pcs	Kg	Width mm.	S+L	Euro cad. Promo
T	4,8	30	100	3000	480	100	1	0,36	10	30937	4,40
T	9,6	60	50	3000	960	100	1	0,36	10	30904/ECO	6,30
T	9,6	60	50	4000	960	100	1	0,36	10	90.011/010	5,40
T	14,4	78	38.46	3000	1440	100	1	0,36	8	40904	6,00
T	19,2	120	25	3000	1920	100	1	0,36	10	30904	7,00
T	19,2	120	25	4000	1920	100	1	0,36	10	90.012/010	7,80

Fino ad esaurimento scorte  
While stocks last



**CRI 90**

**IP67**

colour	W/m	Led/mt *	Pitch LED	K	Lm/m	Efficiency	pcs	Kg	Width mm.	S+L	Euro cad. Promo
T	4,8	30	100	3000	480	100	1	0,36	12	90.001/012	8,80
T	9,6	60	50	3000	960	100	1	0,36	12	90.011/012	8,70
T	9,6	60	50	4000	960	100	1	0,36	12	90.011/011	9,90
T	14,4	78	38.46	3000	1440	100	1	0,36	12	40904/IP67	8,00
T	19,2	120	25	3000	1920	100	1	0,36	12	90.001/012PLUS	10,00
T	19,2	120	25	4000	1920	100	1	0,36	12	90.001/011PLUS	9,00

\*Quantità dei LED per metro lineare  
\*Quantity of LEDs per linear meter

Fino ad esaurimento scorte  
While stocks last

### Dati fotometrici Photometric data

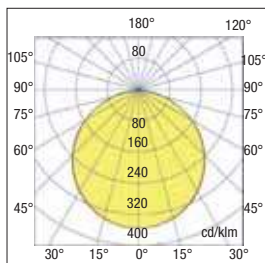

### Accessori inclusi - Included accessories



**Per codici IP20**  
**For IP20 codes**  
2 Cavi di connessione al driver di 15 cm.  
2 Connection cables to the driver 15 cm.



2 Connettori per linea continua.  
2 Connectors for continuous line.

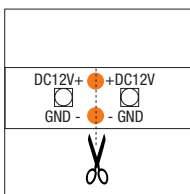

Effettuare il taglio in corrispondenza del simbolo della forbice e la linea tratteggiata.  
Make the cut in correspondence of the scissor symbol and dotted line.



**Per codici IP67**  
**For IP67 code**

La confezione contiene, clip di fissaggio, tappi di chiusura, cavi di collegamento IP ad alimentatore, tubo silicone per ripristino IP, connessioni iniziale e finale strip e per collegamento in serie. Le strip possono essere sezionate ad intervalli prefissati; in caso di tagli intermedi utilizzare i tappi inclusi ed assicurarsi di sigillare accuratamente le estremità tagliate.

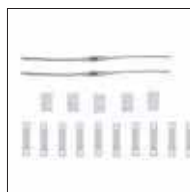

The package contains fixing clips, closure caps, IP connection cables to power supply, silicone hose for IP reset, initial and final strip connections and connection in series. The strips can be sectioned at preset intervals; in the case of intermediate cuts, use the included caps and make sure to carefully seal the cut ends



# LED Flex monocromatica 24 Vdc IP20 - IP67

## LED Flex monocromatica 24V.



A richiesta con consegna a 90 giorni, color 2200K - 2700K - 5000K e 6500K.  
On request with delivery in 90 days, color 2200K - 2700K - 5000K and 6500K.

### Dati fotometrici Photometric data

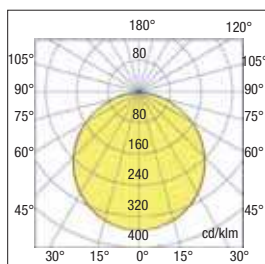

CRI 90

IP20



colour	W/m	Led/mt*	Pitch LED	K	Lm/m	Efficiency	pcs	Kg	Width mm.	S+L	
T	4,8	30	166.67	3000	480	100	1	0,36	10	30937/24	
T	9,6	60	100	3000	960	100	1	0,20	10	30904/ECO/24	
T	9,6	60	100	4000	960	100	1	0,20	10	90.011/010/24	
T	14,4	78	76.92	3000	1440	100	1	0,36	8	40904/24	
NEW	T	16	210	33.33	2700	1552	97	1	0,36	8	RB210208-27
NEW	T	16	210	33.33	3000	1600	100	1	0,36	8	RB210208-30
T	19,2	120	50	3000	1920	100	1	0,20	10	30904/24/PLUS	
T	19,2	120	50	4000	1920	100	1	0,20	10	30670/24/PLUS	
NEW	T	22,4	224	35.71	3000	3136	140	1	0,20	10	R224210-30
NEW	T	22,4	224	35.71	4000	3584	160	1	0,20	10	R224210-40
T	24	280	25	3000	2400	100	1	0,20	10	90.001/012/24	

CRI 90

IP67

colour	W/m	Led/m*	Pitch LED	K	Lm/m	Efficiency	pcs	Kg	Width mm.	S+L	
T	4,8	30	166.67	3000	480	100	1	0,36	12	90.001/024	
T	9,6	60	100	3000	960	100	1	0,20	12	90.011/012/24	
T	9,6	60	100	4000	960	100	1	0,20	12	90.011/011/24	
T	14,4	78	76.92	3000	1440	100	1	0,36	10	40904/IP67/24	
NEW	T	16	210	33.33	2700	1552	97	1	0,36	10	RB210208-2767
NEW	T	16	210	33.33	3000	1600	100	1	0,36	10	RB210208-3067
T	19,2	120	50	3000	1920	100	1	0,20	12	90.001/012PLUS24	
T	19,2	120	50	4000	1920	100	1	0,20	12	90.001/011PLUS24	

\*Quantità dei LED per metro lineare - \*Quantity of LEDs per linear meter

# LED Flex monocromatica 48 Vdc - IP20

## LED Flex monocromatica 48V



colour	W/m	Led/mt*	Pitch LED	K	Lm/m	Efficiency	pcs	Kg	Width mm.	S+L	
NEW	T	19,2	120	33.33	3000	1632	100	1	0,36	10	30904/48
NEW	T	19,2	120	33.33	4000	1728	100	1	0,36	10	90.012/010/48

\*Quantità dei LED per metro lineare - \*Quantity of LEDs per linear meter



# LED Flex COB monocromatica 24 Vdc IP20 - IP67

## LED Flex COB monocromatica 24V.



IP 20  
100 lm/W m

24Vdc

A richiesta con consegna a 90 giorni:  
On request with delivery in 90 days:

RED

GREEN



CRI 90

IP20



COMPATIBLE  
cod. 20072  
cod. 20074



	colour	W/m	K	Lm/m	Efficiency	pcs	Kg	Width mm.	S+L
NEW	G	10	2700	850	85	1	0,20	8	30904/COB/27K
	G	10	3000	850	85	1	0,20	8	30904/COB
	G	10	4000	950	95	1	0,20	8	30904/COB/4K
NEW	G	15	3000	1500	100	1	0,30	10	RCOB528210-30
NEW	G	15	4000	1500	100	1	0,30	10	RCOB528210-40



IP 67  
100 lm/W m

24Vdc

A richiesta con consegna a 90 giorni  
color 2200K, 5000K e 6500K.

On request with delivery in 90 days,  
color 2200K, 5000K and 6500K.

CRI 90

IP67



COMPATIBLE  
cod. 20072  
cod. 20074

	colour	W/m	K	Lm/m	Efficiency	pcs	Kg	Width mm.	S+L
NEW	G	10	2700	950	95	1	0,20	10	30905/COB/27K
NEW	G	10	3000	950	95	1	0,20	10	30905/COB/3K
	G	10	4000	950	95	1	0,20	10	30905/COB

### Dimensioni - Dimension

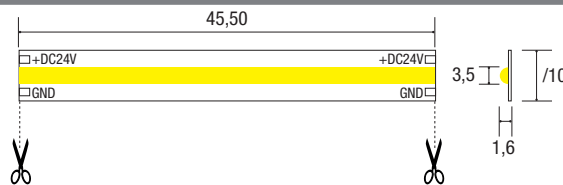
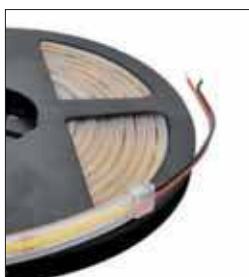

### Dati fotometrici Photometric data

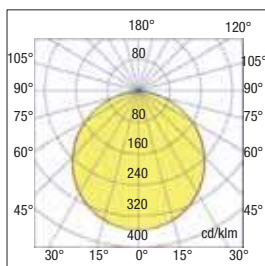

### Accessori inclusi - Included accessories

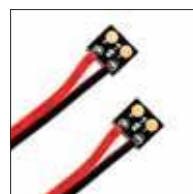

Per codici IP20 - For IP20 codes 4  
2 Cavi 15cm di connessione al driver  
2 15cm Connection cables to the driver



2 Connettori per linea continua.  
2 Connectors for continuous line.



Per codici IP67 - For IP67 code

La confezione contiene, clip di fissaggio, tappi di chiusura, cavi di collegamento IP ad alimentatore, tubo silicone per ripristino IP, connessioni iniziale e finale strip e per collegamento in serie. Le strip possono essere sezionate ad interassi prefissati; in caso di tagli intermedi utilizzare i tappi inclusi ed assicurarsi di sigillare accuratamente le estremità tagliate.

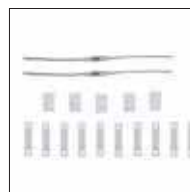

The package contains fixing clips, closure caps, IP connection cables to power supply, silicone hose for IP reset, initial and final strip connections and connection in series. The strips can be sectioned at preset intervals; in the case of intermediate cuts, use the included caps and make sure to carefully seal the cut ends



# LED Flex Tunable white 24 Vdc IP20 - IP67

## LED Flex Tunable white

2700K



CRI 90

IP20



colour	W/m	Led/m*	Pitch LED	K	Lm/m	Efficiency	pcs	Kg	Width mm.	S+L
T	20	120	50	2700 - 6500	1500	100	1	0,26	10	30937/TW

4000K



CRI 90

IP67

colour	W/m	Led/m*	Pitch LED	K	Lm/m	Efficiency	pcs	Kg	Width mm.	S+L
T	9,6	60	100	2700 - 6500	960	100	1	0,30	12	30904/TW

\*Quantità dei LED per metro lineare - \*Quantity of LEDs per linear meter

6500K



### Temperature di colore dinamiche sull'esempio della natura

Non di rado, le persone trascorrono la maggior parte della giornata in ambienti chiusi. Grazie alla regolazione della temperatura di colore da bianco caldo a freddo, gli effetti naturali della luce e i relativi vantaggi entrano all'interno degli ambienti. Come hanno dimostrato gli studi, la luce fredda e molto azzurra stimola l'attività e la concentrazione, mentre la luce calda rilassa.

In questo modo Tunable White crea un ambiente capace di sostenere le persone in modo naturale, al pari di quanto fa la luce diurna.

Tunable White significa regolazione variabile della temperatura di colore dalla tonalità calda a quella fredda.

Se la temperatura di colore e l'illuminamento sono dosati correttamente, la luce artificiale è in grado di dare sostegno al benessere delle persone, sia in uffici e strutture didattiche che negli ospedali e nei centri di cura.

### Dynamic colour temperatures following nature's example

More and more often, people spend most of the day indoors. Thanks to the continuous adjustment of the colour temperature from warm to cold white, the natural effects of light and the relative advantages enter into the rooms.

As studies have shown, cold and very blue light stimulates activity and concentration, while warm light relaxes.

In this way, Tunable White creates an environment capable of supporting people in a natural way, just like daylight.

Tunable White means variable adjustment of the colour temperature from warm to cold.

If the colour temperature and illuminance are dosed correctly, artificial light is able to support people's well-being, both in offices and educational facilities as well as in hospitals and treatment centres.

### Dati fotometrici Photometric data

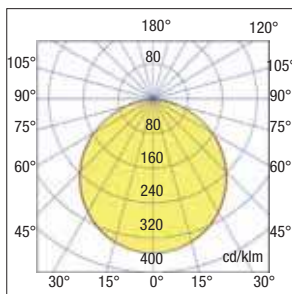

### Zubehör inbegriffen - Accessoires inclus



#### Per codici IP20 For IP20 codes

Cavi 15cm di connessione al driver  
15cm Connection cables to the driver

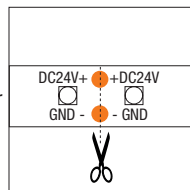

Effettuare il taglio in corrispondenza del simbolo della forbice e la linea tratteggiata.

Make the cut in correspondence of the scissor symbol and dotted line.



#### Per codici IP67 - For IP67 code

La confezione contiene, clip di fissaggio, tappi di chiusura, cavi di collegamento IP ad alimentatore, tubo silicone per ripristino IP, connessioni iniziale e finale strip e per collegamento in serie. Le strip possono essere sezionate ad interassi prefissati; in caso di tagli intermedi utilizzare i tappi inclusi ed assicurarsi di sigillare accuratamente le estremità tagliate.

The package contains fixing clips, closure caps, IP connection cables to power supply, silicone hose for IP reset, initial and final strip connections and connection in series.

The strips can be sectioned at preset intervals; in the case of intermediate cuts, use the included caps and make sure to carefully seal the cut ends



Connettore per linea continua.  
Connector for continuous line.





## Profili in alluminio dissipanti da incasso Recessed aluminium heat sink profile

Profili **dissipanti** in alluminio, disponibili da incasso, per superfici piane e da incasso a scomparsa curvabili, obbligatorie per LED Flex (non incluse), con diffusore, clip di fissaggio e testata di chiusura (non inclusi) per installazione singola o in fila continua, a parete, a plafone o ad incasso.

**Materiale:** profilo **dissipante** in lega d'alluminio anodizzato naturale.

**Testata di chiusura:** in polimero termoplastico da ordinare separatamente.

**Diffusore:** trasparente o opale in PMMA da ordinare separatamente.

*Aluminium heat sink profiles, available for recessed installation, for flat surfaces and for concealed recessed installation, bendable, mandatory for LED Flex (not included), with diffuser, fastening clip and end caps (not included), suitable for single or in-line installation, wall, ceiling-mounted or recessed.*

**Material:** heat sink profile anodized aluminium alloy.

**End cap:** made of thermoplastic polymer to be ordered separately.

*Transparent or opal PMMA diffuser to be ordered separately.*

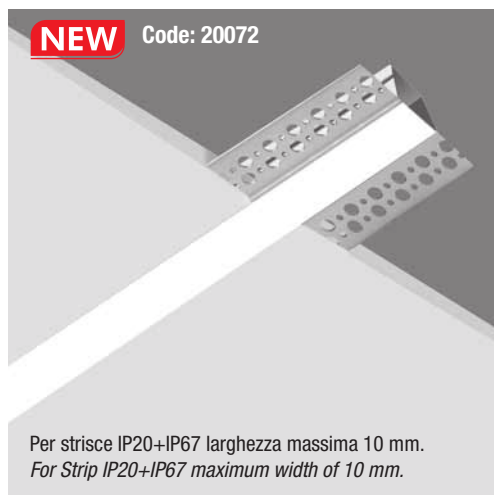

**NEW** Code: 20072

Per strisce IP20+IP67 larghezza massima 10 mm.  
For Strip IP20+IP67 maximum width of 10 mm.

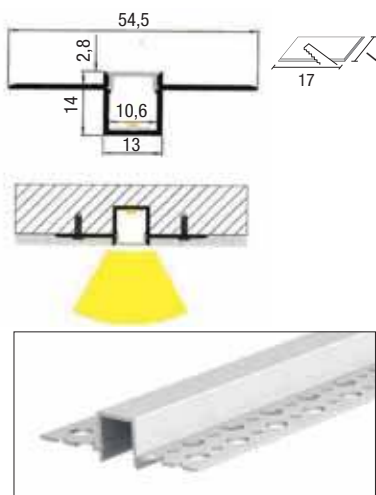

### Recessed KIT H 14

Profilo dissipante in alluminio **da incasso**. Lunghezza: 2 metri

### Recessed KIT H 14

Recessed aluminium heat sink profile. Length: 2 meters

Art.	Finitura Finishing	Kg	L (mm)	Code
Recessed KIT H 14	Alluminio Aluminium	0,7	2000	20072

Per linee di luce continue incassate in cartongesso a rasare, striscia LED non inclusa.  
For continuous light lines embedded in plasterboard to be smoothed, strip led not included.



### accessori non inclusi accessories not included

Code: MT.20072

tappi di chiusura. Non inclusi.  
end caps. Not included



### accessori non inclusi accessories not included

Code: D.20072

Diffusore satinato.  
Lunghezza 2m.

**Satin-finished** diffuser.  
Length 2m.

## Profili in alluminio dissipanti per superfici piane Recessed aluminium heat sink profile for flat surface



Code: 20070-A

Per strisce IP20+IP67  
For Strip IP20+IP67

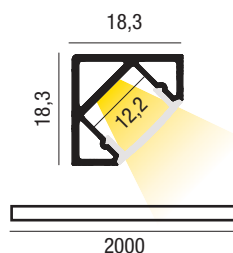

### Code: MT.20070-A

Kit composto da clip di fissaggio e tappi di chiusura. Non inclusi.  
Kit that includes fastening clips and end caps. Not included



### KIT ANGOLO H 18,3

Profilo dissipante in alluminio. Lunghezza: 2 metri

### KIT CORNER H 18,3

Aluminium heat sink profile. Length: 2 meters

Art.	Finitura Finishing	Kg	L (mm)	Code
KIT ANGOLO H 18,3	Alluminio Aluminium	0,6	2000	20070-A

Per gole di luce continue  
For continuous cove lighting





**Profili in alluminio a scomparsa ad incasso curvabile.**  
**Recessed curved aluminum profiles.**



**Recessed KIT H 14**  
 Profilo dissipante in alluminio **da incasso**. Lunghezza: 2 metri  
**Recessed KIT H 14**  
 Recessed aluminium heat sink profile. Length: 2 meters

Art.	Finitura Finishing	Kg	L (mm)	Code
Recessed KIT H 14	Alluminio Aluminium	0,7	2000	20074

Per linee di luce continue incassate in cartongesso a rasare, striscia LED non inclusa.  
 For continuous light lines embedded in plasterboard to be smoothed, strip led not included.

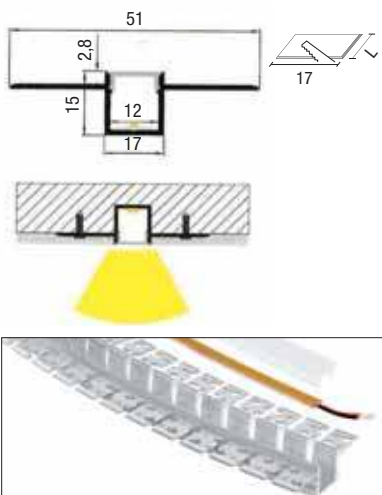

Per strisce IP20+IP67 larghezza massima 10 mm.  
 For Strip IP20+IP67 maximum width of 10 mm.

**Per utilizzo con / For use with:**

**LED Flex monocromatica 12V. - 24V.**



**LED Flex COB monocromatica 24V.**



**LED Flex Tunable white**



**DIFFUSORI - accessori non inclusi - DIFFUSERS - accessories not included**



**Code: 17158**  
 tappi di chiusura. Non inclusi.  
 end caps. Not included



**Code: 17074N**  
 Diffusore satinato bianco Lunghezza 2m.  
**White satin-finished**  
 diffuser. Length 2m.



**Code: 1707BN**  
 Diffusore satinato nero Lunghezza 2m.  
**Black satin-finished**  
 diffuser. Length 2m.

Per la copertura in silicone nero, l'illuminazione è di circa il 15%, esce una luce lieve.  
 For the black silicone cover, the lighting rate is about 15%, a little light come out.



Code: 20071



Solo per strisce IP20  
For Strip IP20 only

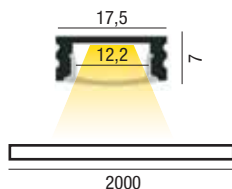

Code: MT.20071

Kit composto da clip di fissaggio e tappi di chiusura. Non inclusi.  
Kit that includes fastening clips and end caps. Not included



KIT H 7

Profilo dissipante in alluminio. Lunghezza: 2 metri

**KIT CORNER H 7**

Aluminium heat sink profile. Length: 2 meters

Art.	Finitura Finishing	Kg	L (mm)	Code
KIT H 7	Alluminio Aluminium	0,7	2000	20071

Per nicchie di luce continue  
For continuous light alcoves

Code: 20070-I



Per strisce IP20+IP67  
For Strip IP20+IP67

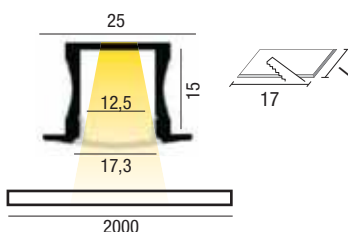

Code: MT.20070-I

Kit composto da clip di fissaggio e tappi di chiusura. Non inclusi.  
Kit that includes fastening clips and end caps. Not included



Recessed KIT H 15

Profilo dissipante in alluminio da incasso. Lunghezza: 2 metri

**Recessed KIT H 15**

Recessed aluminium heat sink profile. Length: 2 meters

Art.	Finitura Finishing	Kg	L (mm)	Code
Recessed KIT H 15	Alluminio Aluminium	0,7	2000	20070-I

Per linee di luce continue incassate in cartongesso  
For continuous recessed lines of light

Code: 20070



Per strisce IP20+IP67  
For Strip IP20+IP67

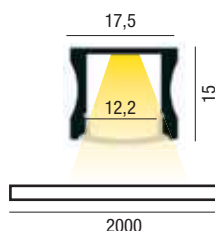

Code: MT.20070

Kit composto da clip di fissaggio e tappi di chiusura. Non inclusi.  
Kit that includes fastening clips and end caps. Not included



KIT H 15

Profilo dissipante in alluminio. Lunghezza: 2 metri

**KIT H 15**

Aluminium heat sink profile. Length: 2 meters

Art.	Finitura Finishing	Kg	L (mm)	Code
KIT H 15	Alluminio Aluminium	0,6	2000	20070

Per linee di luce continue  
For continuous lines of light



Code: D.20070-1

Diffusore trasparente.  
Lunghezza 2m.

**Transparent** diffuser.  
Length 2m.



Code: D.20070-2

Diffusore satinato.  
Lunghezza 2m.

**Satin-finished** diffuser.  
Length 2m.

# LED Neon IP67



Per i Driver vedi da pag. 623 a 627 - For Driver see from page 623 to 627



Stip LED

# LED Neon IP67 6X12



## LED Neon 6X12 SIDE VIEW

IP 67  
max 850 lm/m

24Vdc



SIDE VIEW

6X12 mm

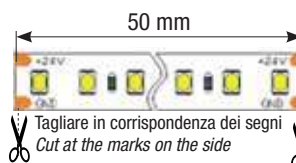

	colour	W/m	Led/m*	Pitch LED	K	Lm/m	Lm/W	pcs	Kg	Width mm.	S+L
NEW	W	10	120	6	3000	850	80	001	1.2	5	81.1030.67.24
NEW	W	10	120	6	2700	750	75	001	1.2	5	81.1027.67.24

# LED Neon IP67 10X10

## LED Neon 10X10 FRONT VIEW

IP 67  
max 1120 lm/m

24Vdc



FRONT VIEW

10X10 mm

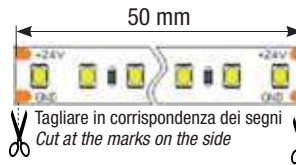

	colour	W/m	Led/m*	Pitch LED	K	Lm/m	Lm/W	pcs	Kg	Width mm.	S+L
NEW	W	14	120	6	3000	1120	80	001	1.4	8	83.1430.67.24
NEW	W	14	120	6	2700	1050	75	001	1.4	8	83.1427.67.24

## LED Neon 10X10 SIDE VIEW

IP 67  
max 1120 lm/m

24Vdc



SIDE VIEW

10X10 mm

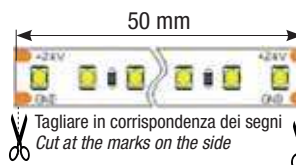

	colour	W/m	Led/m*	Pitch LED	K	Lm/m	Lm/W	pcs	Kg	Width mm.	S+L
NEW	W	14	120	8	3000	1120	80	001	1.4	8	82.1430.67.24
NEW	W	14	120	8	2700	1050	75	001	1.4	8	82.1427.67.24

## Accessori inclusi - Included accessories



La confezione contiene, clip di fissaggio, tappi di chiusura, cavi di collegamento IP ad alimentatore, tubo silicone per ripristino IP, connessioni iniziale e finale strip e per collegamento in serie.

Le strip possono essere sezionate ad interassi prefissati; in caso di tagli utilizzare i tappi inclusi ed assicurarsi di sigillare accuratamente le estremità tagliate.

The package contains fixing clips, closure caps, IP connection cables to power supply, silicone hose for IP reset, initial and final strip connections and connection in series.

The strips can be sectioned at preset intervals; in the case of cuts, use the included caps and make sure to carefully seal the cut ends.





Per i Driver vedi da pag. 623 a 627 - For Driver see from page 623 to 627



Strip LED

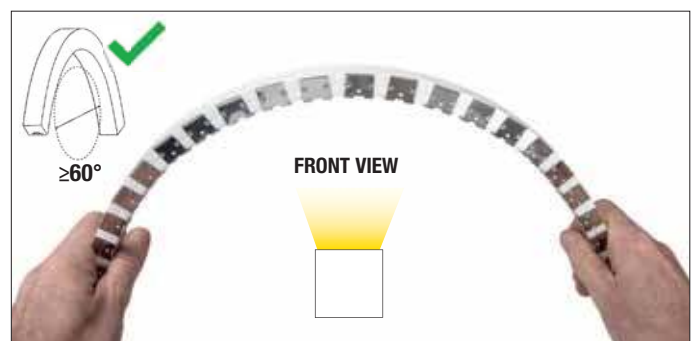
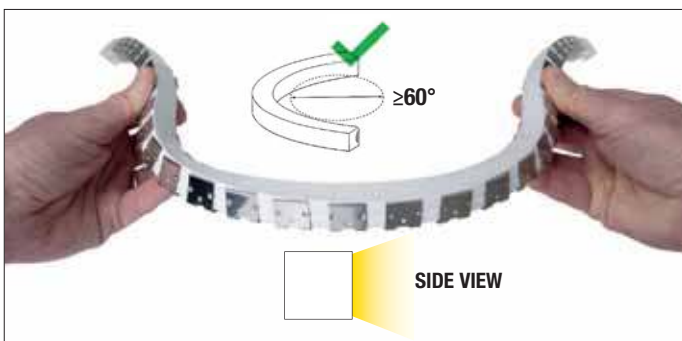

# LED Neon IP67

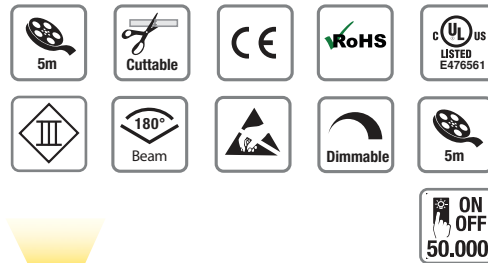

**CRI 90**

**IP67**

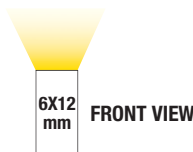

colour	W/m	Led/m*	Pitch LED	K	Lm/m	Lm/W	pcs	Kg	Width mm.	S+L
W	8	320	100	3000	256	32	001	0.30	6	RN3COB320208

## Dimensioni - Dimension

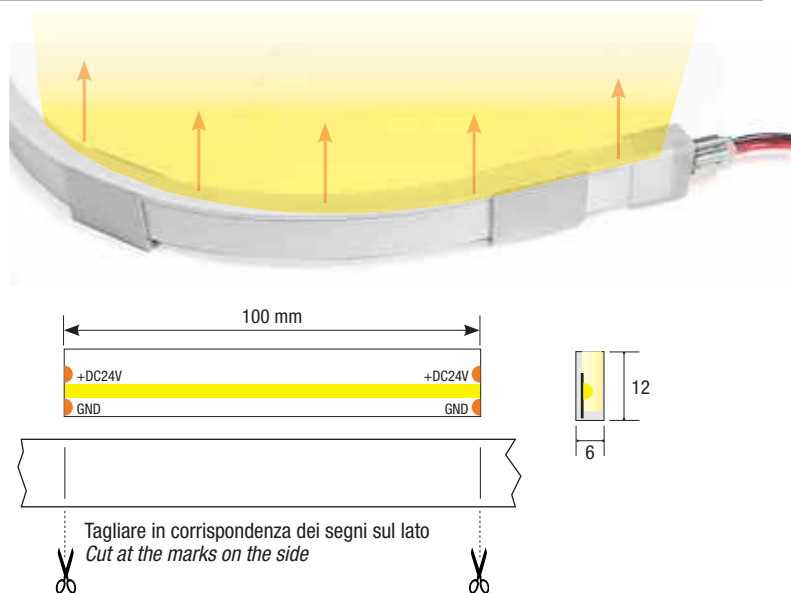
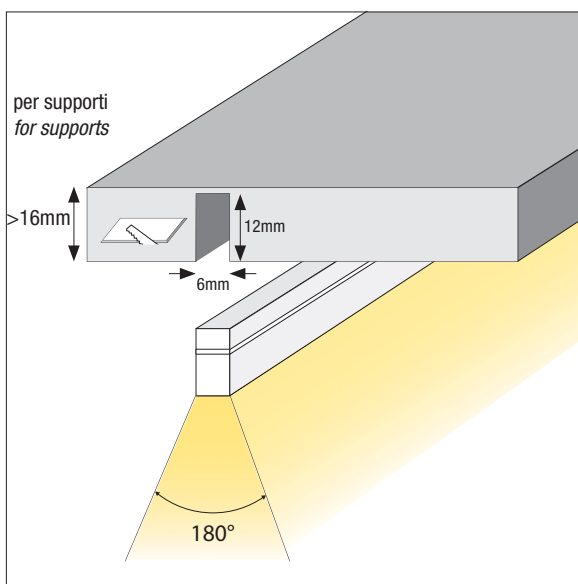

Tagliare in corrispondenza dei segni sul lato  
Cut at the marks on the side

LED Flex COB Vertical può essere inserita su qualsiasi supporto, su cartongesso o inserita in mobili in legno, dopo aver predisposto il supporto a foro adeguato si inserisce semplicemente a pressione, inoltre non necessita di profili dissipanti visto la bassa potenza (8W/m) e di conseguenza l'esiguo calore emesso.

LED Flex COB Vertical can be inserted on any support, on plasterboard or inserted in wooden furniture, after having prepared the suitable hole support it is simply inserted by pressure, moreover it does not require dissipating profiles given the low power (8W/m) and consequently the little heat emitted.

## Accessori inclusi - Included accessories



### Per codici IP67 - For IP67 code

La confezione contiene, clip di fissaggio, tappi di chiusura, cavi di collegamento IP ad alimentatore, tubo silicone per ripristino IP, connessioni iniziale e finale strip e per collegamento in serie.

Le strip possono essere sezionate ad interassi prefissati; in caso di tagli utilizzare i tappi inclusi ed assicurarsi di sigillare accuratamente le estremità tagliate.

The package contains fixing clips, closure caps, IP connection cables to power supply, silicone hose for IP reset, initial and final strip connections and connection in series.

The strips can be sectioned at preset intervals; in the case of cuts, use the included caps and make sure to carefully seal the cut ends

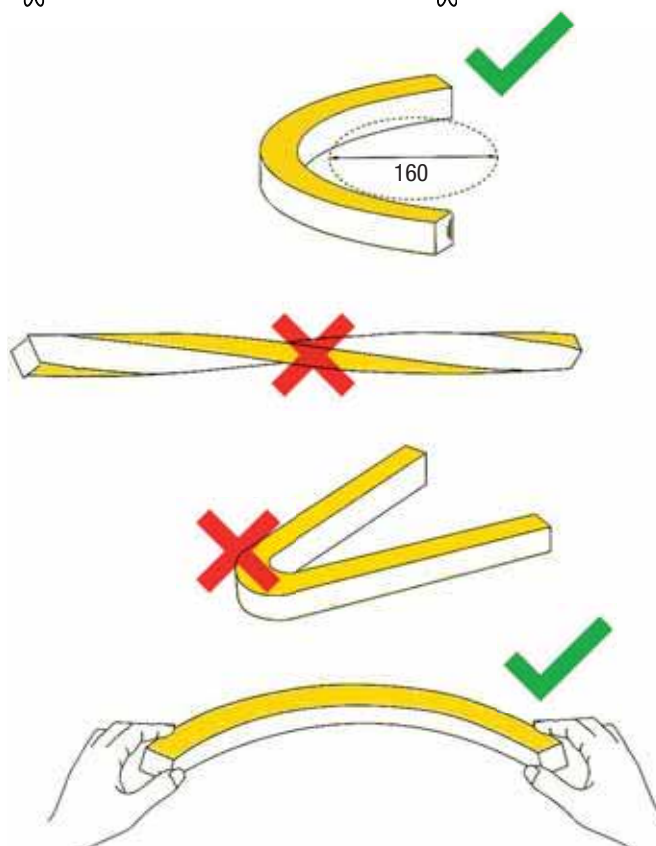

# Profili in alluminio dissipanti per LED Neon

## LED Neon aluminium heat sink profile

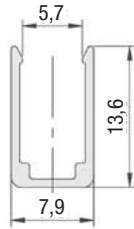

Profilo dissipante in alluminio. Lunghezza: 2 metri  
Aluminium heat sink profile. Length: 2 meters

Art.	Finitura Finishing	Kg	L (mm)	Code
1616RS	Alluminio Aluminium	0,7	2000	1616RS

Per nicchie di luce continue  
For continuous light alcoves

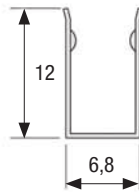

Profilo dissipante in acciaio **flessibile**. Lunghezza: 2 metri  
Flexible steel dissipating profile. Length: 2 meters

Art.	Finitura Finishing	Kg	L (mm)	Code
flexible 1616S	Alluminio Aluminium	0,7	2000	1616S

Per gole di luce continue incassate in cartongesso  
For continuous light grooves recessed in plasterboard

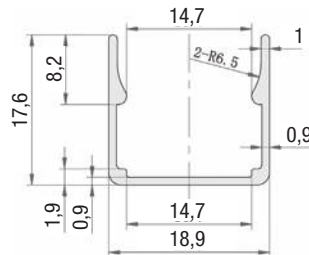

Profilo dissipante in alluminio. Lunghezza: 2 metri  
Aluminium heat sink profile. Length: 2 meters

Art.	Finitura Finishing	Kg	L (mm)	Code
1616RF	Alluminio Aluminium	0,7	2000	1616RF

Per nicchie di luce continue  
For continuous light alcoves

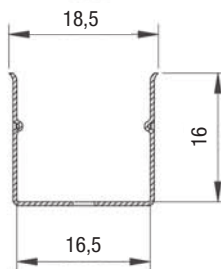
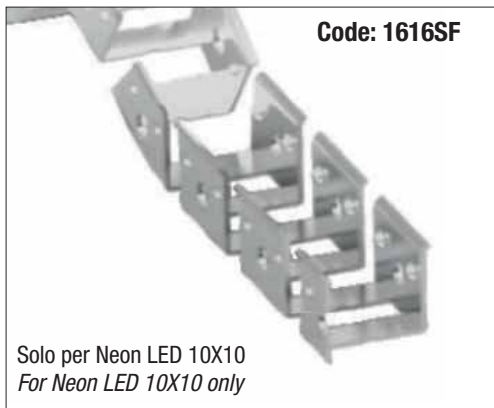

Profilo dissipante in acciaio **flessibile**. Lunghezza: 2 metri  
Flexible steel dissipating profile. Length: 2 meters

Art.	Finitura Finishing	Kg	L (mm)	Code
flexible 1616S	Alluminio Aluminium	0,7	2000	1616S

Per gole di luce continue incassate in cartongesso  
For continuous light grooves recessed in plasterboard



# Misure strisce LED flessibili - Flexible LED strip sizes

## LED Flex monocromatica 12Vdc IP20 - IP67



Led/m	Vdc	Width mm.	IP/20	IP/67
30	12V.	8		
60	12V.	10		
78	12V.	8		
120	12V.	10		

## LED Flex monocromatica 24 Vdc IP20 - IP67

Led/m	Vdc	Width mm.	IP/20	IP/67
30	24V.	8		
60	24V.	10		
78	24V.	8		
120	24V.	10		
210	24V.	8		
224	24V.	10		
280	24V.	10		

# Misure strisce LED flessibili - Flexible LED strip sizes

## LED Flex COB monocromatica 24 Vdc IP20 - IP67

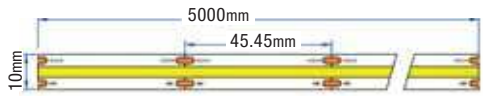
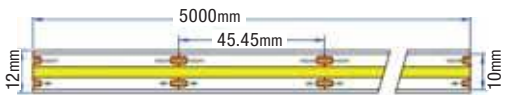
Led/m	Vdc	Width mm.	IP/20	IP/67
528	24V.	8		
528	24V.	10		

## LED Flex monocromatica 48 Vdc - IP20

Led/m	Vdc	Width mm.	IP/20	IP/67
120	48V.	10		

## LED Flex Tunable white 24 Vdc IP20 - IP67

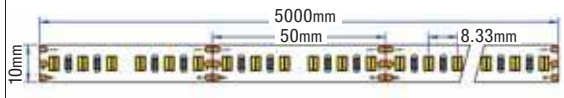
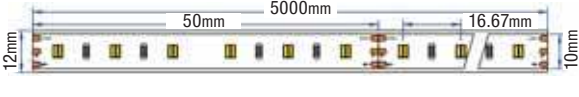
Led/m	Vdc	Width mm.	IP/20	IP/67
120	24V.	10		-
60	24V.	10	-	

## LED Neon 24 Vdc - IP67

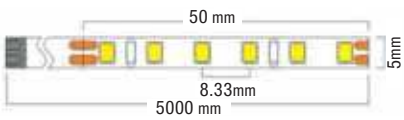
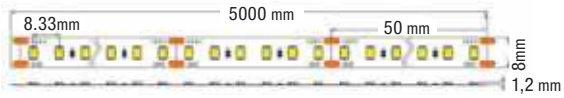
Led/m	Vdc	Width mm.	IP/67
120	24V.	5	
120	24V.	8	

# LED Agile Silicone 24Vdc IP65

AUF ANFRAGE  
SUR DÉMANDE

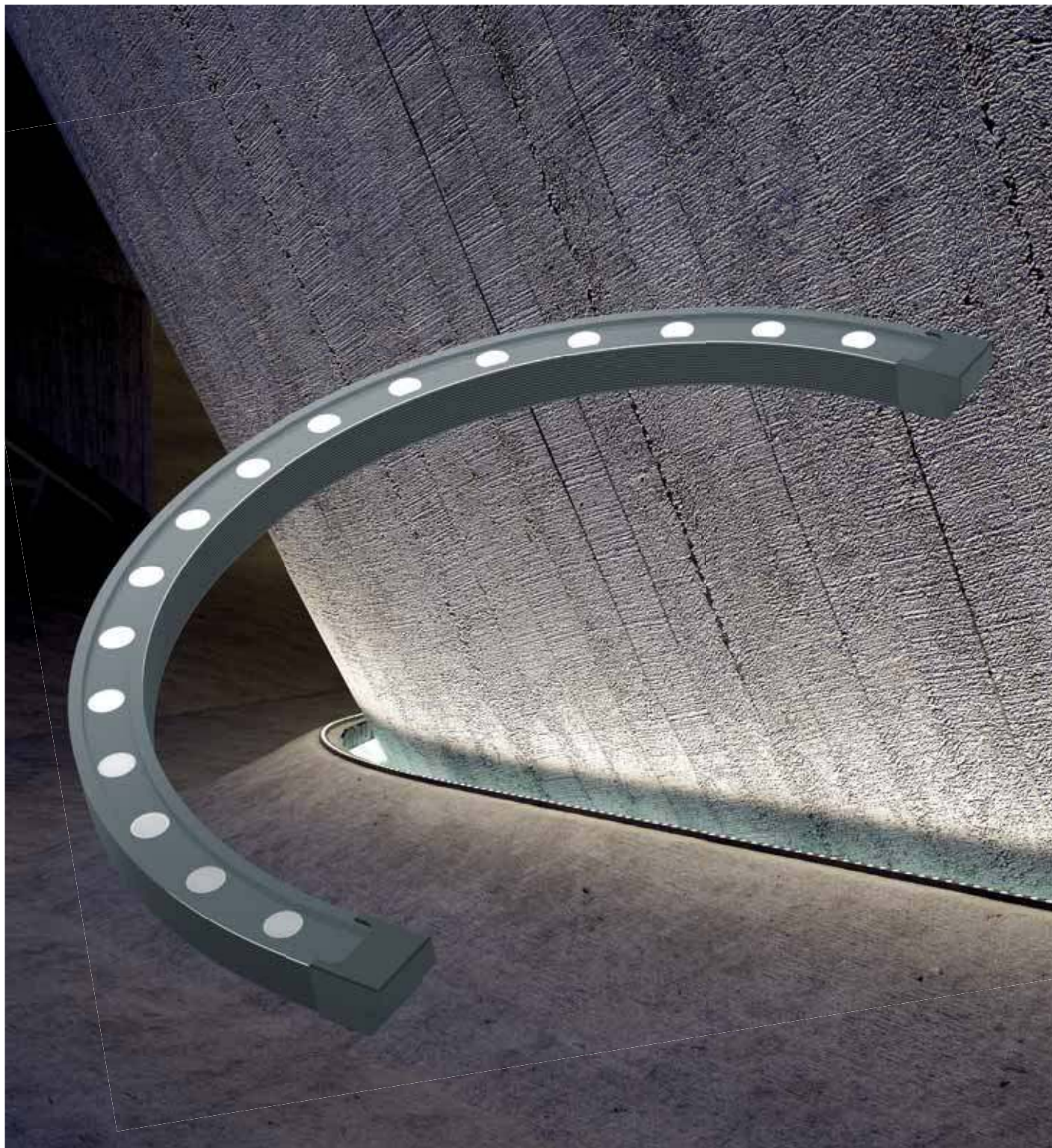

LED Agile Silicone ist ein Produkt für lineare Außenbeleuchtung mit einem hohen Schutzgrad IP65.

Die Stärke dieses Produkts ist seine Flexibilität. Es kann sich sowohl horizontal als auch vertikal biegen. All dies ist dank der Silikon-Coextrusion und der Verwendung unabhängiger Leiterplatten möglich. Durch die Anordnung mehrerer Lampen nebeneinander wird ein gleichmäßiges Licht abgegeben und es bilden sich keine Schattenbereiche.

**Optik:** Ausgestattet mit einer kontrollierten Optik mit einem Abstrahlwinkel von 30°, wodurch die Beleuchtung großer Höhen (bis zu ca. 12 Metern) ermöglicht wird.

**Montage:** auf fester oder verstellbarer Halterung oder mit Aluminiumprofil.

**Körper:** Silikon und thermoplastisches Material.

**Stromversorgung:** 24 V, nicht im Lieferumfang enthalten.

*LED Agile Silicone est un produit pour l'éclairage linéaire extérieur avec un haut degré de protection IP65.*

*Le point fort de ce produit est sa flexibilité, en effet il est capable de se plier aussi bien sur l'axe horizontal que vertical ; tout cela est possible grâce à la coextrusion de silicone et à l'utilisation de PCB indépendants. En plaçant plusieurs lampes côte à côte, la lumière émise sera uniforme et aucune zone d'ombre ne se formera.*

**Optique :** équipée d'une optique contrôlée avec un angle de faisceau de 30°, permettant ainsi l'éclairage de hauteurs importantes (jusqu'à environ 12 mètres).

**Installation :** sur support fixe ou réglable ou avec profilé aluminium.

**Corps :** Silicone et matériau thermoplastique.

**Alimentation :** 24V non incluse.

## LED Agile Silicone 24V.

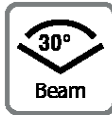

Nur auf Anfrage.  
Sur demande uniquement.



colour	W	L. mm.	W/m	K	Lm	DC	pcs	Kg	Width mm.	S+L
G	72,5	2500	29	2700	4000	24	1	0,36	40	AGI25027G
G	72,5	2500	29	3000	4250	24	1	0,36	40	AGI25030G
G	72,5	2500	29	4000	4450	24	1	0,36	40	AGI25040G
G	72,5	2500	20	R G B	1500	24	1	0,36	250	AGI250RGBG

### Fotometrische Daten Données photométrique

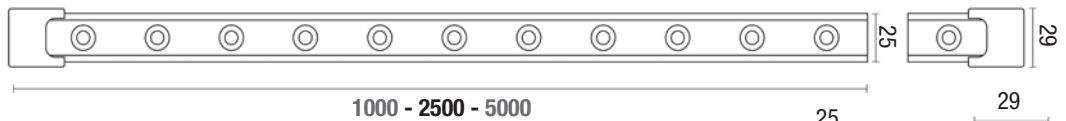
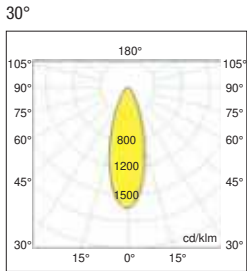

Auf Anfrage.  
Sur demande.

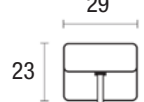
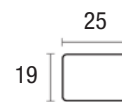

50 cm Ein-/Ausgangskabel  
Câble entrée/sortie de 50 cm

### Zubehör nicht enthalten - Accessoires non inclus



**RE-FL129-1**  
1 Meter Aluminiumprofil.  
Profilé aluminium de 1 mètre.



**RE-FL129**  
Feste Befestigungshalterung.  
Support fixe.



**RE-CT580-BLE Steuerunit Bluetooth Mesh**  
*Bluetooth Mesh Unité de contrôle*  
Bluetooth Mesh-Steuerunit, steuerbar per Push, dedizierter Smartphone-App (iOS und Android) und Sprachassistenten (Google Home und Alexa).  
Steuerunit zum Verwalten und Dimmen aller Arten von Agile-LED, Monochrom oder RGB. Ausgang: 5 Kanäle – Max. 8 A x Kanal.  
Unité de contrôle Bluetooth Mesh gérable par push, application smartphone dédiée (iOS et Android) et assistants vocaux (Google Home et Alexa).  
Unité de contrôle pour la gestion et la gradation de tous types de LED Agile, Monochrome ou RGB. Sortie : 5 canaux - Max 8 A x canal



Äußere Kappen für das Profil wie auf dem Foto gezeigt  
Bouchons extérieurs au profil comme indiqué sur la photo

**RE-FL129-2**  
2 Meter Aluminiumprofil.  
Profilé aluminium de 2 mètres.

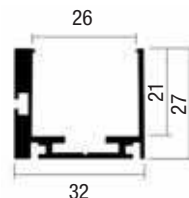

**RE-FL129-X**  
Einstellbare Unterstüzung.  
Support réglable.



# SLIM CV LED DRIVER 48V



Alimentatore indipendente IP20 per uso interno.

Fornito di coprimorsetto e serracavo.

- Morsetti di entrata e uscita contrapposti
- Ripple di tensione:  $\pm 5\%$
- Campo di regolazione: DALI 2
- Tipo di protocollo: DALI 2
- Protezione: circuito aperto/Cortocircuito/Sovraccarico
- Protetto in classe II contro le scosse elettriche per contatti diretti e indiretti
- Temperatura ambiente:  $-20...45^{\circ}\text{C}$
- Certificati: ENEC / CCC / SAA / CB CE
- Applicazioni: striscia LED DC
- Tensione nominale: 220-240V - 50/60Hz

IP20 independent power supply for indoor use.

Supplied with terminal cover and cable clamp.

- Opposite input and output terminals
- Voltage ripple:  $\pm 5\%$
- Setting range: DALI 2
- Protocol type: DALI 2
- Protection: Open Circuit / Short Circuit / Overload
- Protected in class II against electric shocks for direct and indirect contacts
- Ambient temperature:  $-20...45^{\circ}\text{C}$
- Certificates: ENEC / CCC / SAA / CB CE
- Applications: DC LED strip
- Rated voltage: 220-240V - 50/60Hz

	Code Code	Watt Range	Output voltage Vdc	Output current mA	Input voltage Vdc	Hz			Protocol	Power factor	L (mm)	P (mm)	H (mm)
NEW	RN9175/48/75	75	48	0-1800mA	-	50/60	15	25A 200µS	ON-OFF	0,95 λ	180	52	30
NEW	RN9175/48/120	120	48	0-2500 mA	-	50/60	15	25A 200µS	ON - OFF	0,95 λ	300	40	30
NEW	RN9175/48/250	250	48	0-5210 mA	-	50/60	15	25A 200µS	ON - OFF	0,95 λ	400	40	22

## Integrated invisible power supply 48V

- Ripple di corrente:  $\pm 5\%$
- Short time:  $<0,5\text{s} / 277\text{Vac}$
- Tc:  $-40-85^{\circ}\text{C}$
- Applicazioni: binario 48V
- Colore: Nero

- Current ripple:  $\pm 5\%$
- Short time:  $<0,5\text{s} / 277\text{Vac}$
- Tc:  $-40-85^{\circ}\text{C}$
- Applications: Track light 48V
- Colour: Black

		Code Code	Watt Range	Output voltage Vdc	Output current A	Input voltage Vdc	Hz			Power factor	L (mm)	P (mm)	H (mm)
NEW	<b>N</b>	RLV100W48VT3M	100	48	0-2,5	220-240	50/60	15	25A 200µS	0,95 λ	290	15	18
NEW	<b>N</b>	RLV250W48VTW	250	48	0-2,5	220-240	50/60	15	25A 200µS	0,95 λ	258	15	44
NEW	<b>B</b>	RLV100W48VTWH	100	48	0-2,5	220-240	50/60	15	25A 200µS	0,95 λ	290	15	18
NEW	<b>B</b>	RLV250W48VTWH	250	48	0-2,5	220-240	50/60	15	25A 200µS	0,95 λ	258	15	44

Cavo a 4 poli (2X funzionamento ON/OFF - 2 per funzionamento DALI) - 4-pole cable (2X ON/OFF operation - 2 for DALI operation)

# FLAT CV LED DRIVER 24V



RIPPLE FREE

IP20



SELV



Alimentatore indipendente IP20 per uso interno.

Fornito di coprimorsetto e serracavo.

- Morsetti di entrata e uscita contrapposti
- Ripple di tensione:  $\pm 5\%$
- Protezione: circuito aperto/Cortocircuito/Sovraccarico
- Protetto in classe II contro le scosse elettriche per contatti diretti e indiretti
- Temperatura ambiente:  $-20...40^{\circ}\text{C}$
- Applicazioni: striscia LED DC
- Tensione nominale: 220-240V - 50/60Hz

IP20 independent power supply for indoor use.

Supplied with terminal cover and cable clamp.

- Opposite input and output terminals
- Voltage ripple:  $\pm 5\%$
- Protection: Open Circuit / Short Circuit / Overload
- Protected in class II against electric shocks for direct and indirect contacts
- Ambient temperature:  $-20...40^{\circ}\text{C}$
- Certificates: ENEC / CCC / SAA / CB CE
- Applications: DC LED strip
- Rated voltage: 220-240V - 50/60Hz

	Codice Code	Watt Range	Output voltage Vdc	Output current mA	Input voltage Vdc	Hz		Power factor	L (mm)	P (mm)	H (mm)
NEW	7064CV	8 - 40	24	333-1667 mA	220-240	50/60	10	0,95 $\lambda$	160	57,5	18
NEW	7065CV	12 - 60	24	500-2500 mA	220-240	50/60	10	0,95 $\lambda$	185	63,5	22

A richiesta potenze 6W - 12W - 15W - 20W - 30W - On request powers 6W - 12W - 20W - 30W

## Accessori non inclusi - Not included accessories

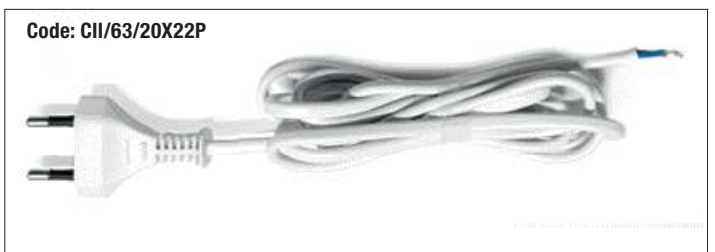
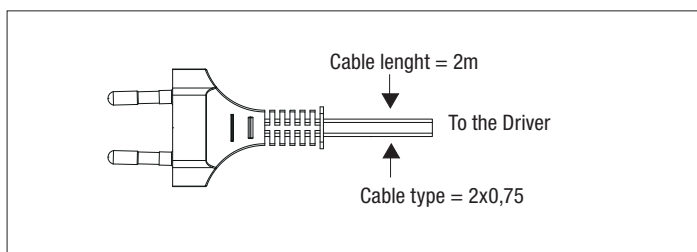
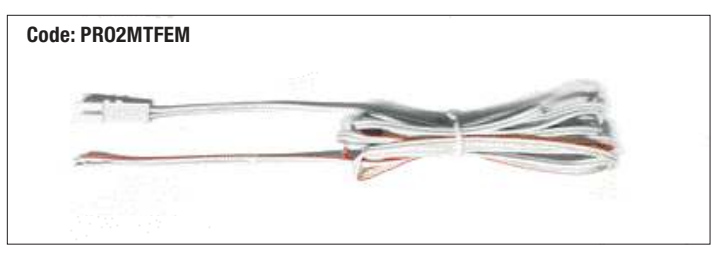
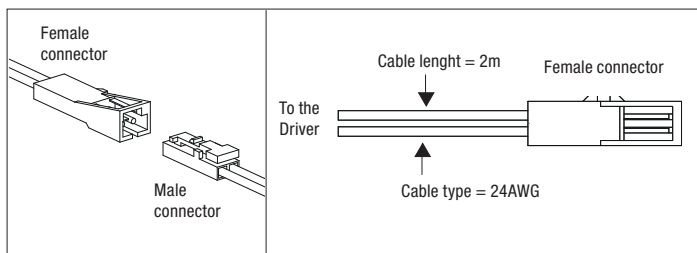
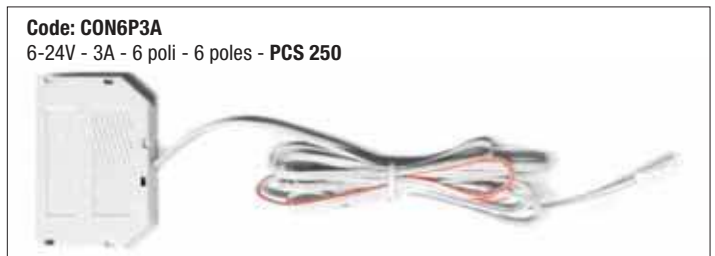
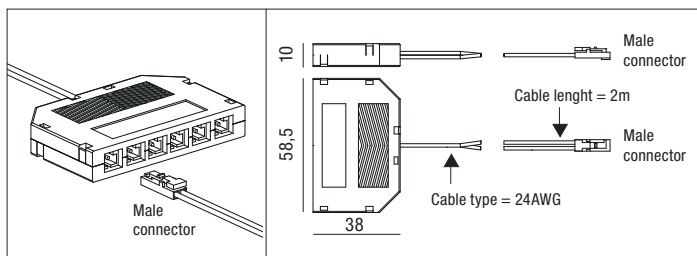

# COMPACT CV LED DRIVER 12V



Alimentatore indipendente IP20 per uso interno.

Fornito di coprimorsetto e serracavo.

- Morsetti di entrata e uscita contrapposti
- Ripple di tensione:  $\pm 5\%$
- Campo di regolazione: 1-10V 1%-100%
- Tipo di protocollo: 1-10V
- Protezione: circuito aperto/Cortocircuito/Sovraccarico
- Protetto in classe II contro le scosse elettriche per contatti diretti e indiretti
- Temperatura ambiente:  $-20...45^{\circ}\text{C}$
- Certificati: ENEC / CCC / SAA / CB CE
- Applicazioni: striscia LED DC
- Tensione nominale: 220-240V - 50/60Hz

IP20 independent power supply for indoor use.

Supplied with terminal cover and cable clamp.

- Opposite input and output terminals
- Voltage ripple:  $\pm 5\%$
- Setting range: 1-10V 1%-100% - DALI 2
- Protocol type: 1-10V - DALI 2
- Protection: Open Circuit / Short Circuit / Overload
- Protected in class II against electric shocks for direct and indirect contacts
- Ambient temperature:  $-20...45^{\circ}\text{C}$
- Certificates: ENEC / CCC / SAA / CB CE
- Applications: DC LED strip
- Rated voltage: 220-240V - 50/60Hz

	Codice Code	Watt Range	Output voltage Vdc	Output current	Hz			Protocol	Power factor	L (mm)	P (mm)	H (mm)	QTY	PROMO Euro Netto
	PTDC/5/12V/N	5	12	420 mA	50/60	30	10A 40 $\mu$ S	ON - OFF	*	40	42	21	2.900	1,50
	PTDCL1012VB	9	12	750 mA	50/60	30	10A 40 $\mu$ S	ON - OFF	*	145	22	22	800	3,00
	RN9014	30	12	2500 mA	50/60	25	20A 175 $\mu$ S	ON - OFF	0,95 $\lambda$	170	41	35		
	PTDC/50/12V	60	12	5000 mA	50/60	15	20A 175 $\mu$ S	ON - OFF	0,95 $\lambda$	180	52	30	2.275	5,00
	RN9175	100	12	8350 mA	50/60	15	20A 175 $\mu$ S	ON - OFF	0,95 $\lambda$	230	51	40	1.246	13,50
	RN1392	25	12 24	2100 mA 1000 mA	50/60	25	20A 175 $\mu$ S	ON - OFF	0,95 $\lambda$	145	39	28	2.416	7,00
	PTDC/80/B	50 80	12 24	4170 mA 3350 mA	50/60	15	25A 200 $\mu$ S	ON - OFF	0,95 $\lambda$	230	51	40		
	PTDCD/100	60 100	12 24	5000 mA 4170 mA	50/60	15	25A 200 $\mu$ S	1-10Vdc PUSH (SELV)	0,95 $\lambda$	230	51	40		

\* Per potenze inferiori a 24W non è richiesto dalle normative - For lower powers to 24W is not required by the regulations

# COMPACT CV IP67 LED DRIVER 12V/24V



Alimentatore indipendente IP67.

- Cavo di connessione su primario e secondario per il collegamento
- Protetto in classe I contro le scosse elettriche per contatti diretti e indiretti
- Ripple di tensione:  $\pm 5\%$
- Campo di regolazione: DALI 2
- Tipo di protocollo: DALI 2
- Temperatura ambiente:  $-20...45^{\circ}\text{C}$
- Certificati: ENEC / CCC / SAA / CB CE
- Applicazioni: striscia LED DC
- Tensione nominale: 220-240V - 50/60Hz

IP67 independent power supply.

- Connection cable on primary and secondary for connection
- Class I protected against electric shocks for direct and indirect contacts
- Voltage ripple:  $\pm 5\%$
- Setting range: DALI 2
- Protocol type: DALI 2
- Ambient temperature:  $-20...45^{\circ}\text{C}$
- Certificates: ENEC / CCC / SAA / CB CE
- Applications: DC LED strip
- Rated voltage: 220-240V - 50/60Hz

Codice Code	Watt Range	Output voltage Vdc	Output current mA	Hz			Protocol	Power factor	L (mm)	P (mm)	H (mm)	QTY	PROMO Euro Netto
RN1431/75	75	12	6250 mA	50/60	15	25A 200 $\mu\text{S}$	ON - OFF	0,95 $\lambda$	155	53	31		
RN1431	150	12	12500 mA	50/60	15	25A 200 $\mu\text{S}$	ON - OFF	0,95 $\lambda$	215	53	31	700	14,00
RN1475/24/DA	75	24	3125 mA	50/60	15	44A 288 $\mu\text{S}$		0,95 $\lambda$	131	67	33		
RN1431/24/100	100	24	4160 mA	50/60	15	44A 288 $\mu\text{S}$	ON - OFF	0,95 $\lambda$	164	53	33		
RN7726	150	24	6250 mA	50/60	15	44A 288 $\mu\text{S}$	ON - OFF	0,95 $\lambda$	138	66	34.75		
RN1227	150	24	6250 mA	50/60	15	44A 288 $\mu\text{S}$		0,95 $\lambda$	161	67	33		
RN1431/24	200	24	8330 mA	50/60	15	44A 288 $\mu\text{S}$	ON - OFF	0,95 $\lambda$	181	60	38		
RN7729	350	24	14.580 mA	50/60	15	44A 288 $\mu\text{S}$	ON-OFF	0,95 $\lambda$	218	76.5	38.5		

A richiesta potenze 30W - 60W - 250W (ON-OFF - 1-10V - DALI) - On request powers 30W - 60W - 250W (ON-OFF - 1-10V - DALI)



# COMPACT CV LED DRIVER 24V



- Ripple di tensione:  $\pm 5\%$
- Protezione: circuito aperto/Cortocircuito/Sovraccarico
- Protetto in classe II contro le scosse elettriche per contatti diretti e indiretti
- Temperatura ambiente:  $-20...45^{\circ}\text{C}$
- Certificati: ENEC / CCC / SAA / CB CE
- Applicazioni: striscia LED DC

- Voltage ripple:  $\pm 5\%$
- Protection: Open Circuit / Short Circuit / Overload
- Protected in class II against electric shocks for direct and indirect contacts
- Ambient temperature:  $-20...45^{\circ}\text{C}$
- Certificates: ENEC / CCC / SAA / CB CE
- Applications: DC LED strip

Codice Code	Watt Range	Output voltage Vdc	Output current mA	Hz			Protocol	Power factor	L (mm)	P (mm)	H (mm)	QTY	PROMO Euro Netto
RN1392	25	12	2100 mA	50/60	25	20A 175 $\mu$ S	ON - OFF	0,95 $\lambda$	145	39	28	2.416	7,00
		24	1000 mA										
PTDC/3/24V/N	5	24	210 mA	50/60	30	10A 40 $\mu$ S	ON - OFF	*	40	42	21		
RN1399	8	24	334 mA	50/60	30	10A 40 $\mu$ S	ON - OFF	*	68	35	20		
PTDCL1024VB	10	24	417 mA	50/60	30	10A 40 $\mu$ S	ON - OFF	*	65	35	20		
RN9124	15	24	625 mA	50/60	30	25A 200 $\mu$ S	ON - OFF	*	130	45	16		
RN9015	30	24	1250 mA	50/60	25	20A 175 $\mu$ S	ON - OFF	0,95 $\lambda$	153	41	32		
RN1432-24	40	24	1700 mA	50/60	25	20A 175 $\mu$ S	ON - OFF	0,95 $\lambda$	185	46	38		
RN7669	50	24	2080	50/60	15	25A 200 $\mu$ S	ON - OFF	0,95 $\lambda$	180	52	30		
RN1279	60	24	2500 mA	50/60	15	25A 200 $\mu$ S		0,95 $\lambda$	250	30	21		
RN1428	60	24	2500 mA	50/60	15	10A 170 $\mu$ S	ON - OFF	0,95 $\lambda$	300	30	17		
91756024-DA	60	24	1000-2500 mA	50/60	25	20A 170 $\mu$ S		0,95 $\lambda$	300	30	15		
RN1428/KL	60	24	2500 mA	50/60	15	10A 170 $\mu$ S	ON - OFF	0,95 $\lambda$	180	52	30		
RN7722	75	24	3125	50/60	15	25A 200 $\mu$ S	ON - OFF	0,95 $\lambda$	180	52	30		
RN7724	100	24	4160	50/60	15	25A 200 $\mu$ S	ON - OFF	0,95 $\lambda$	184	61	32		
RN9175/24	120	24	0-5000 mA	50/60	15	25A 200 $\mu$ S	ON - OFF	0,95 $\lambda$	300	40	30		
917515024-DA	150	24	1875-6250 mA	50/60	15	25A 200 $\mu$ S		0,95 $\lambda$	350	30	18		
RN7725	150	24	6250	50/60	15	25A 200 $\mu$ S	ON - OFF	0,95 $\lambda$	210	37	44		
RN9175/24/180	180	24	0-7500 mA	50/60	15	25A 200 $\mu$ S	ON - OFF	0,95 $\lambda$	345	50	35		
RN9175/24/200	200	24	0-8350 mA	50/60	15	25A 200 $\mu$ S	ON - OFF	0,95 $\lambda$	400	40	30		



# KZQ-4 - DALI + PUSH + Phse Cut + 0-10V LED DIMMER

**NEW**



Dimensioni (mm) - Dimensions (mm)

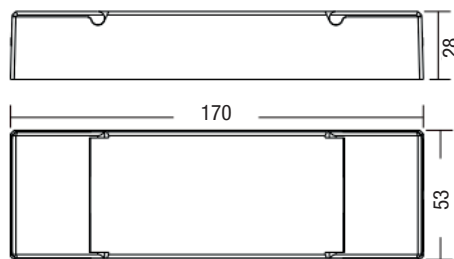

**Norme di riferimento**  
**Reference standard**  
 EN 55015  
 EN 61000-3-2  
 EN 61347-1  
 EN 61347-2-13  
 EN 61547  
 EN 62384  
 EN 62396-207

Code	Input voltage	Output power	Dimming input	DALI Consumption	Dimming range	ta °C
RL-2303P	12-48Vdc	1x (240-960)W	DALI & AC Push & 0/1-10 & Phase Cut	2mA	0,1%-100%	-20....50°

- Dimmer LED multifunzione 4 in 1 con interfaccia DALI, AC push, 0/1-10 V e multifase
- Conforme a tutti gli standard IEC 62386-101:2014, IEC 62386-102:2014 e IEC 62386-207 Ed2
- Interfaccia DALI-2 integrata, dispositivo DALI DT6
- Compatibile con tutti i sistemi DALI presenti sul mercato
- DIP switch per la selezione di diverse interfacce dimmer
- Alimentazione 12-48 VDC su 1 canale, max. 20 A
- Supporta la penetrazione di fase ascendente e discendente
- 1 DALI assegnato al master DALI
- Compatibile con dimmer universali a taglio di fase
- Utilizzare un potenziometro per aumentare la potenza a piacere indefinitamente.
- 4-in-1 multifunction LED dimmer with DALI interface, AC push, 0/1-10 V, and multiple phases
- Complies with all standards IEC 62386-101:2014, IEC 62386-102:2014, and IEC 62386-207 Ed2
- Integrated DALI-2 interface, DALI device DT6
- Compatible with all DALI systems on the market
- DIP switches for selecting different dimmer interfaces
- Power supply 12-48 VDC on 1 channel, max. 20 A
- Supports up- and down-phase penetration
- 1 DALI assigned to the DALI master
- Compatible with universal phase cutting dimmers
- Use a potentiometer to expand the power as desired indefinitely.

### Avvertenze di sicurezza

- NON È POSSIBILE selezionare l'incidenza della luce se il dispositivo è accessibile.
- L'installazione NON deve essere eseguita mentre il dispositivo è alimentato.
- Il dispositivo non deve essere lanciato in aria.

### Safety Warnings

- You CANNOT select the light incidence if the device is accessible.
- Installation must NOT be performed while the device is energized.
- The device must not be thrown into the air.

### Funzione

DIP switch per la selezione dell'ingresso dimmer  
 Innanzitutto, selezionare l'interfaccia di ingresso del dimmer utilizzando un DIP switch nella base del sistema di controllo utilizzato. Non è possibile cablare e utilizzare contemporaneamente diverse interfacce dimmer. È possibile cablare singolarmente fino a 4 volt.

### DALI è assegnato al master DALI.

Selezionare il dimmer di ingresso DALI; l'indicatore DALI può essere assegnato automaticamente al controller master DALI. Per le procedure operative specifiche, fare riferimento al Manuale di compatibilità Master DALI.

### Function

DIP Switch for Input Dimmer Selection

First, select the dimmer input interface using a DIP switch in the base of the control system used. It is not possible to wire and use different interface dimmers simultaneously. Individual wiring of up to 4 volts is possible.

### DALI is assigned to the DALI master.

Select the DALI input dimmer; the DALI indicator can be automatically assigned to the DALI master controller. For specific operating procedures, refer to the Master DALI Compatibility Manual.

# KZQ-4 - DALI + PUSH + Phse Cut + 0-10V LED DIMMER

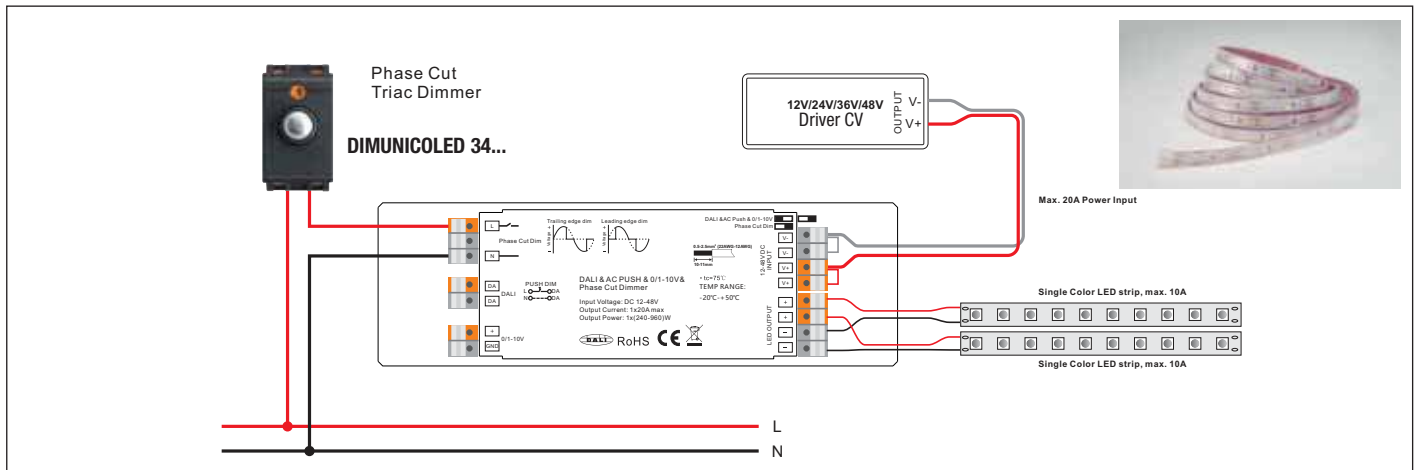
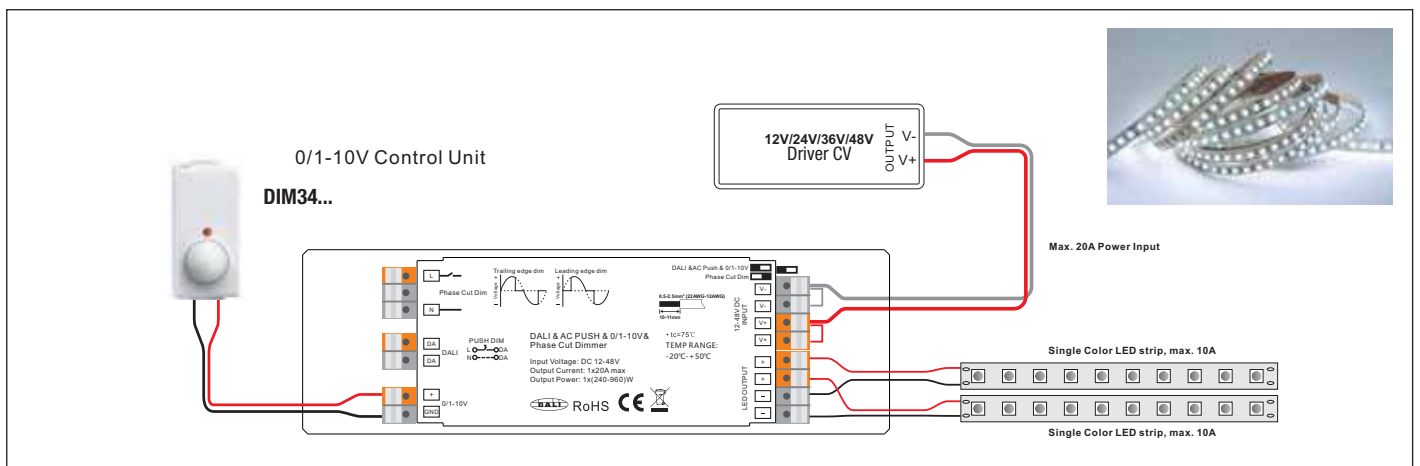
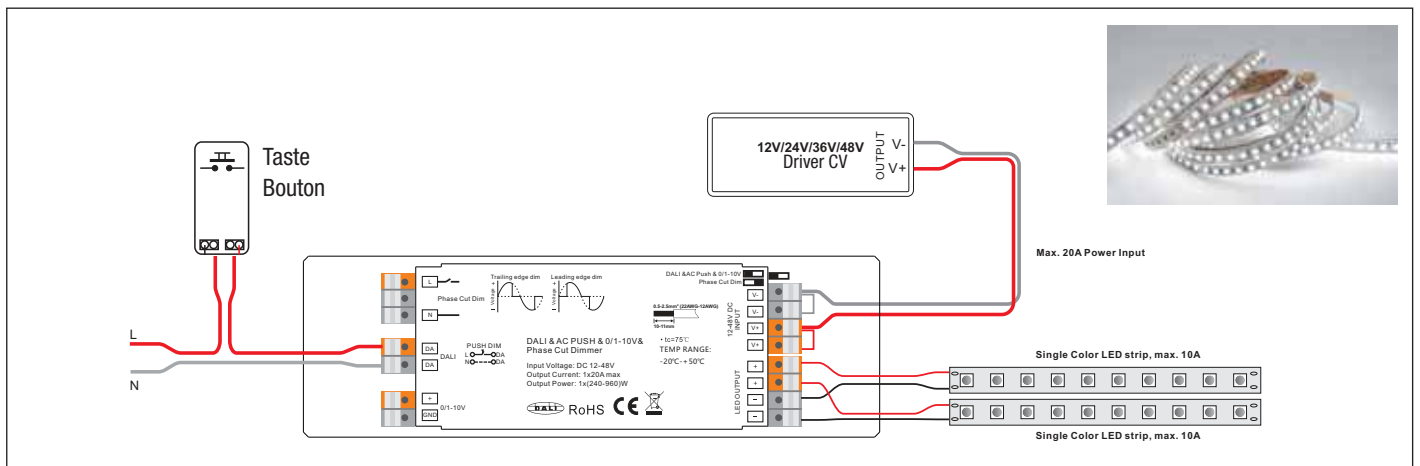
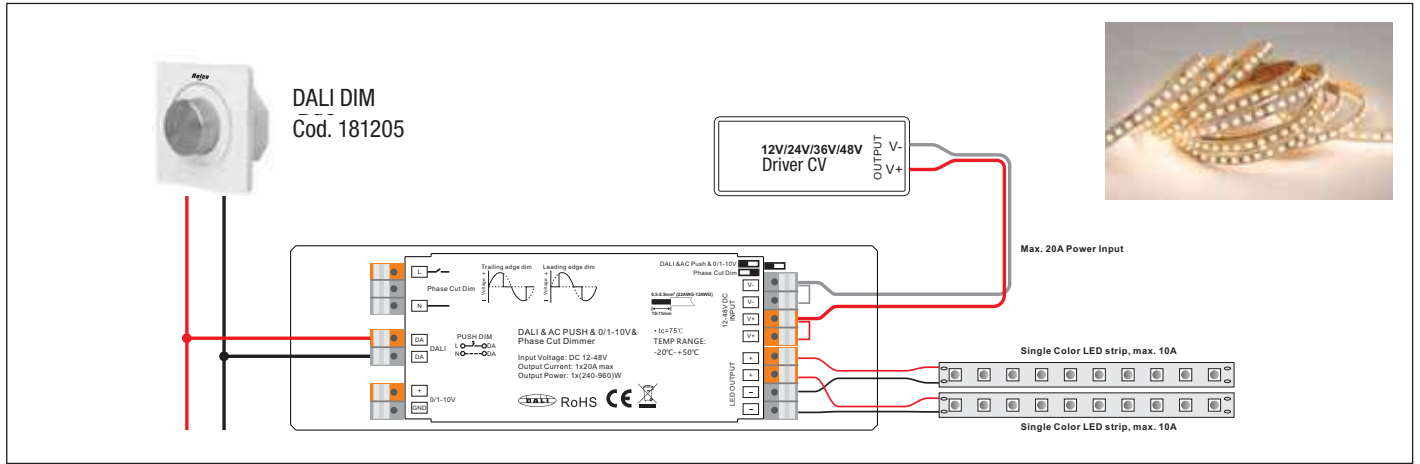

# Dimmer **DALI 2** PUSH

Potenzioentro DALI per scatola tonda, montaggio a parete.  
*DALI power potentiometer for round box, flush mounting.*

Articolo Article	DALI DALI Type	Consumo di energia Power consumption	Corrente in uscita Output current	ta	Peso Weight	Codice Code
		<b>W</b>	<b>mA</b>	<b>°C</b>	<b>Kg</b>	
SR-2400 RB	Type 6	max. 2,3	max. 100	0...+50	0,215	181205



**Tensione Nominale**  
**Rated Voltage**  
 100 ÷ 240 V

**Frequenza**  
**Frequency**  
 50-60 Hz

**Consumo di energia**  
**Power consumption**  
 max. 2,3 W

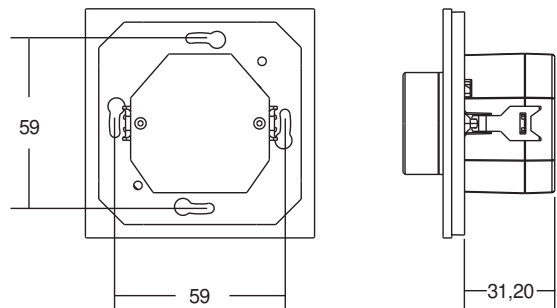

## Regolazione Dali, impianto tradizionale + due fili - *Dali regulation, traditional system + two wires*

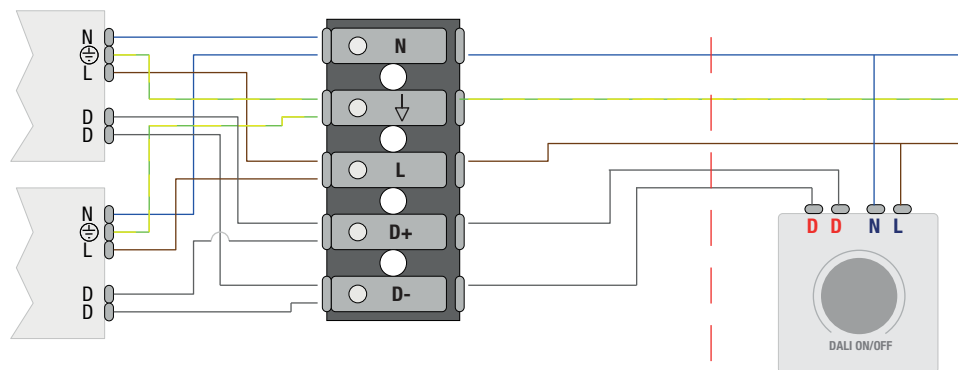

### Caratteristiche

- Progettato per funzionare con sistemi DALI-2.
- Unità di controllo DALI con alimentatore integrato.
- Consente un controllo della luminosità (trasmissione) sino ad un massimo di **50 drivers** senza alimentazione supplementare.
- Collegamento in parallelo di fino a **quattro potenziometri DALI** sino ad un massimo di **100 punti DALI**.
- Lunghezza del cavo di comunicazione DALI: max. 300 metri.
- L'utilizzo di ulteriore potenza potis DALI come estensione (senza il collegamento all'alimentazione integrata).
- Accensione e dimmerazione premendo e girando il pulsante di funzionamento.
- Memorizzazione della luminosità dimpostata e dell'ultima luminosità impostata.

### Features

- Designed to work with DALI-2 systems.
- DALI control unit with integrated power supply.
- Allows a common brightness control (broadcast) of up to **50 DALI drivers** without additional DALI power supply.
- Parallel switching of up to **four DALI power potis** extends the maximum number of **DALI stations to 100**.
- DALI communication cable length: max. 300 mt.
- Use of further DALI power potis as extension (without connection of the integrated power supply).
- Switching and dimming by pressing and turning the operation button.
- Storing of basic brightness and switch-on brightness.



## Installazione - Installation

Schema di collegamento con 2 MCU alimentati da rete CA per controllare fino a 100 ECG DALI  
 Wiring diagram with 2 MCUs powered by AC mains to control up to 100 DALI ECG

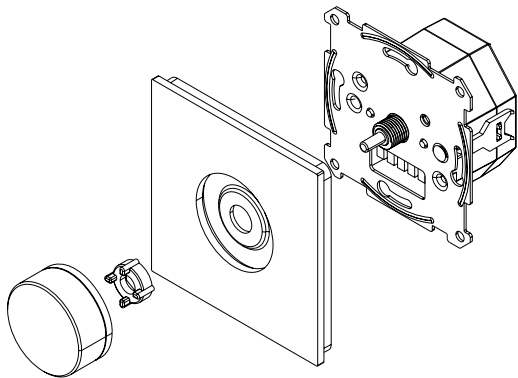

Schema di collegamento - Wiring diagram

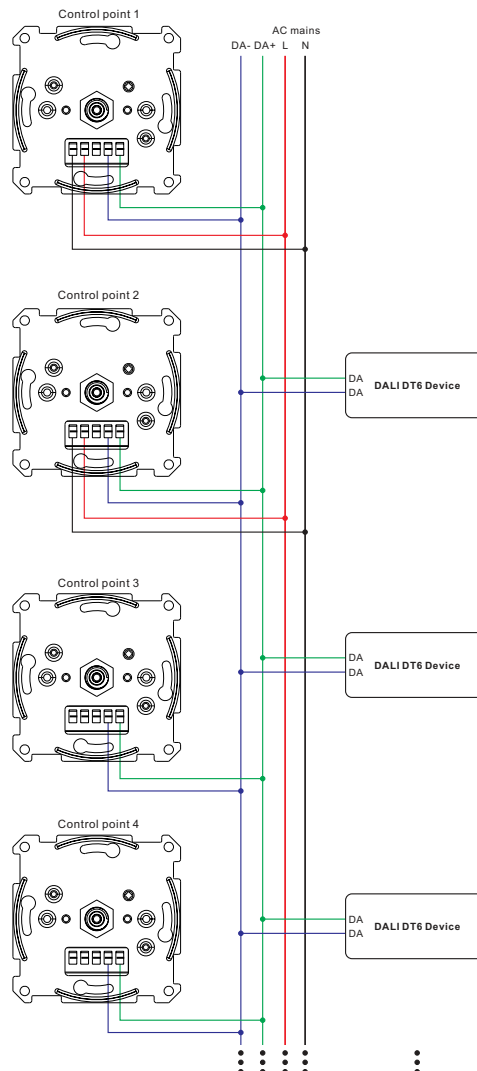
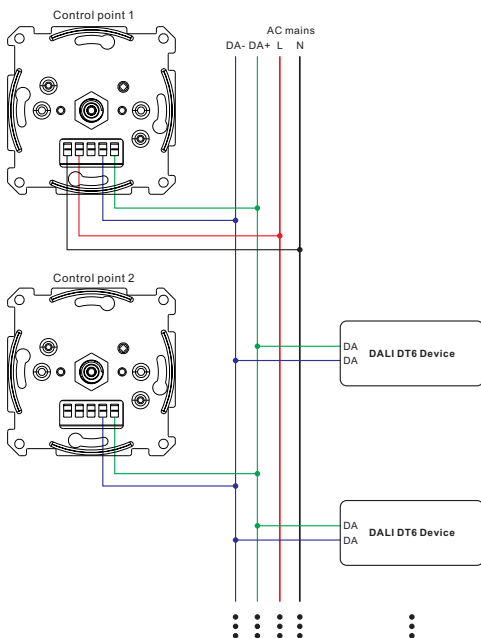

- 1 - To control up to 100 ECG with the setup, there is 2 MCUs connect to AC 220V mains
- 2 - To connect up to 50 ECG with the setup, there is only 1 MCU connect to AC 220V mains, the other MCUs powered by DALI bus. There can be max 2 MCUs connected to the AC mains in the same control circuit. It's suggested to have max 4 MCUs totally in the same control circuit.
- 1 - Per controllare fino a 100 ECG con il sistema, sono necessari 2 MCU collegati alla rete elettrica a 220 V CA.
- 2 - Per collegare fino a 50 ECG con il sistema, è necessario solo 1 MCU collegato alla rete elettrica a 220 V CA, mentre gli altri MCU sono alimentati tramite bus DALI. È possibile collegare al massimo 2 MCU alla rete elettrica CA nello stesso circuito di controllo. Si consiglia di collegare al massimo 4 MCU in totale nello stesso circuito di controllo.

# LED Linee di luce CW - LED Linee di luce CW 3CCT

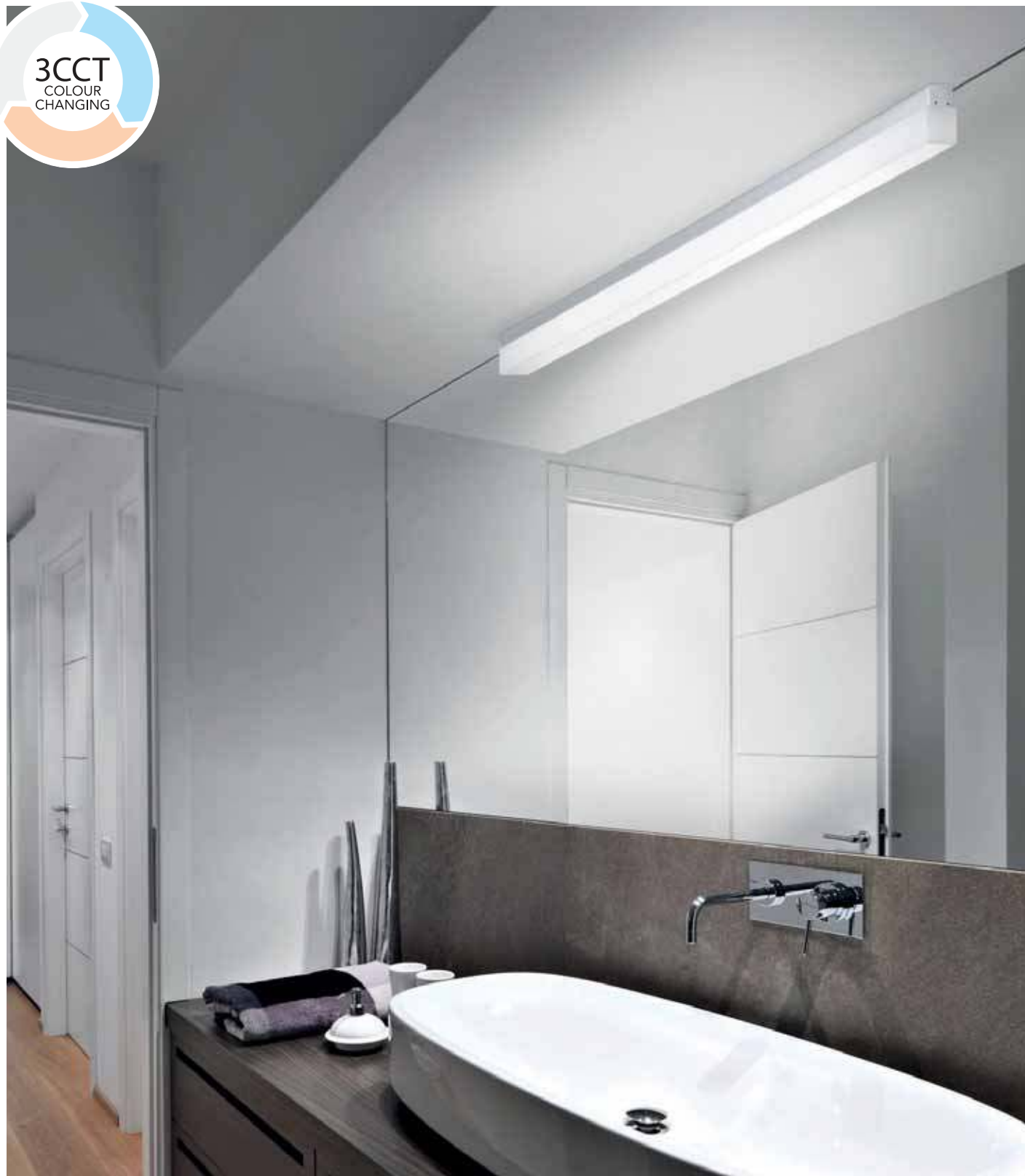

Corpo illuminante a LED in IP44, a sezione rettangolare ideale per l'illuminazione a plafone o parete, idonea per applicazioni in zone umide.

LED Linee di luce ha il vantaggio del tuttoschermo con l'effetto linea di luce continua, da ora disponibile anche versione 3CCT con possibilità di scelta della colorazione del LED, luce calda, luce fredda o luce neutra, tramite pulsante posto sul corpo lampada.

**Installazione:** soffitto e parete

**Corpo:** in alluminio

**Schermo:** diffusore opale in PMMA

**Driver:** incluso

**Interruttore 3CCT:** C (luce fredda) N (luce neutra) W (luce calda) incorporato (solo per versione 3CCT).

*IP44 LED luminaire, with rectangular section, ideal for ceiling or wall lighting, suitable for applications in wet areas. LED Linee di luce has the advantage of full screen with the continuous line of light effect, now also available in the 3CCT version with the possibility of choosing the color of the LED, warm light, cold light or neutral light, using a button located on the lamp body.*

**Installation:** ceiling and wall

**Body:** in aluminum

**Shield:** Opal PMMA diffuser

**Power supply:** included

**3CCT switch:** C (cold light) N (neutral light) W (warm light) incorporated (only for 3CCT version).



220-240V 50/60Hz **IK07** **IP44**

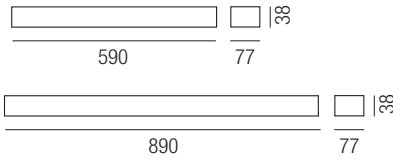

colour	W max	L.	lm output max	K	pcs	Kg	CELL
G	9	590	800	4000	1	1.00	29052/NEW
G	14	890	1300	4000	1	2.00	29057/NEW

220-240V 50/60Hz **IK07** **IP44**

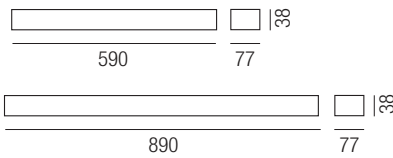

colour	W max	L.	lm output max	K	pcs	Kg	CELL
B	9	590	800	3000	4000	6000	1 1.00 2905152/3CCT
B	14	890	1300	3000	4000	6000	1 2.00 29056-573CCT

**Dati fotometrici**  
**Photometric data**

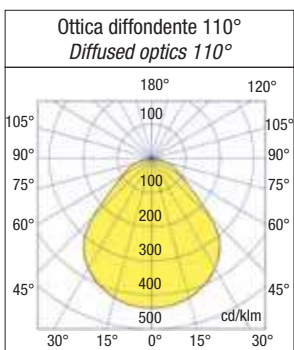

Wall/ceiling

# LED Classica - LED Classica 3CCT



Reglette con tecnologia a led in grado di ridurre notevolmente i consumi rispetto ad una tradizionale reglette. Durata oltre 20.000 ore conforme alle normative di sicurezza.

LED Classica ha il vantaggio del tuttoschermo con l'effetto linea di luce continua, da ora disponibile anche versione 3CCT con possibilità di scelta della colorazione del LED, luce calda, luce fredda o luce neutra, tramite pulsante posto sul corpo lampada.

**Installazione:** soffitto e parete

**Corpo:** in policarbonato Bianco

**Schermo:** diffusore rigato in PMMA

**Cablaggio incluso:** cavo di 1,8m e spina, cavo di 15 cm con due connettori.

**Alimentazione:** inclusa

**Interruttore:** ON/OFF incorporato

**Interruttore 3CCT:** C (luce fredda) N (luce neutra) W (luce calda) incorporato (solo per versione 3CCT).

Provvista di clip per il fissaggio rapido.

*LED technology reglette with significant power economy and energy saving compared to conventional lighting fixture. Long life which last for over 20.000 hours and is fully compliant with applicable safety regulations.*

*LED Classica has the advantage of full screen with the continuous line of light effect, now also available in the 3CCT version with the possibility of choosing the color of the LED, warm light, cold light or neutral light, using a button located on the lamp body.*

**Installation:** ceiling and wall

**Body:** in White polycarbonate

**Shield:** PMMA diffuser

**Wiring included:** 1,8m wire and plug, 15cm wire with two connector.

**Power supply:** included

**Switch:** incorporated ON/OFF

**3CCT switch:** C (cold light) N (neutral light) W (warm light) incorporated (only for 3CCT version).

*Clips included for easy fixing.*



**LED Classica astucci - LED Classica packing**

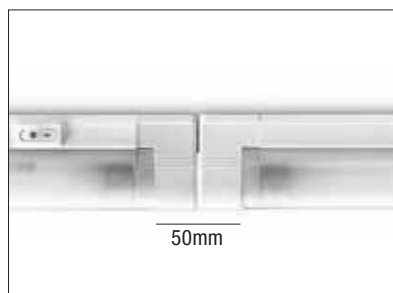

È possibile cablare le lampade in serie fino ad un massimo di 10 lampade. Si suggerisce comunque di utilizzare lampade della stessa potenza. Diversamente potrebbero notarsi piccole differenze di colore tra lampade di diversa potenza.

*The lamps can be connected in series up to max 10 lamps. You are however advised to use lamps of the same power. Lamps of different power can cause variations in colour.*

**LED Classica**



288 (4W)	
516 (7W)	
849 (14W)	
1149 (20W)	
1449 (22W)	

**Disponibile 3CCT**  
**3CCT Available**

**Con interruttore**  
**With switch**

	colour	W		Lm	K			pcs	Kg	CELL	Euro cad. Promo	
	B	4	* (8W)	180°	350	4000			001	0.40	28610	4,00
	B	7	* (13W)	180°	650	3000			001	0.40	28613	
<b>NEW 3CCT</b>	B	7	* (13W)	180°	650	3000	4000	6000	001	0.40	28611/3-4-6K	
	B	14	* (21W)	180°	1150	3000			001	0.40	28605	7,00
<b>NEW 3CCT</b>	B	14	* (21W)	180°	1200	3000	4000	6000	001	0.40	28603/3-4-6K	
	B	20	* (28W)	180°	1850	4000			001	0.50	28604	
<b>NEW 3CCT</b>	B	20	* (28W)	180°	1750	3000	4000	6000	001	0.50	28606/3-4-6K	
	B	22	* (35W)	180°	1950	4000			001	0,60	28614	
<b>NEW 3CCT</b>	B	22	* (35W)	180°	1950	3000	4000	6000	001	0,60	28614/3-4-6K	

\* Potenza FLUO corrispondente - *Corresponding FLUO lamp power*

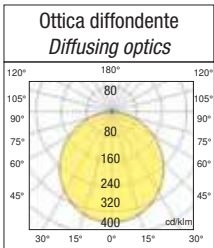

**LED Classica 3CCT**

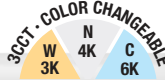

**Accessori inclusi - Included accessories**



- 1 Cod. 24153**  
Cavo di 1,8m con connettore e spina - *1,8m wire with connector and plug*
- 2 Cod. 24157**  
Cavo di 15cm con 2 connettori - *15cm wire with two connector*
- 3 Cod. 24154**  
Accessori fissaggio - *Fixing accessories*

**Accessori non inclusi - Not included accessories**



- 1 Cod. 24151**  
Cavo di 1,8m con connettore a 90° - *1,8m wire with connector at 90°*
- 2 Cod. 24121**  
Cavo di 1m con due connettori - *1m wire with 2 connectors*
- 3 Cod. 24156**  
Cavo di 30cm con due connettori - *30cm wire with two connectors*
- 4 Cod. 24159**  
Cavo di 50cm con due connettori - *50 cm wire with two connectors*
- 5 Cod. 24160**  
Cavo di 50cm con 2 connettori a 90° - *50cm wire with two 90° connectors*

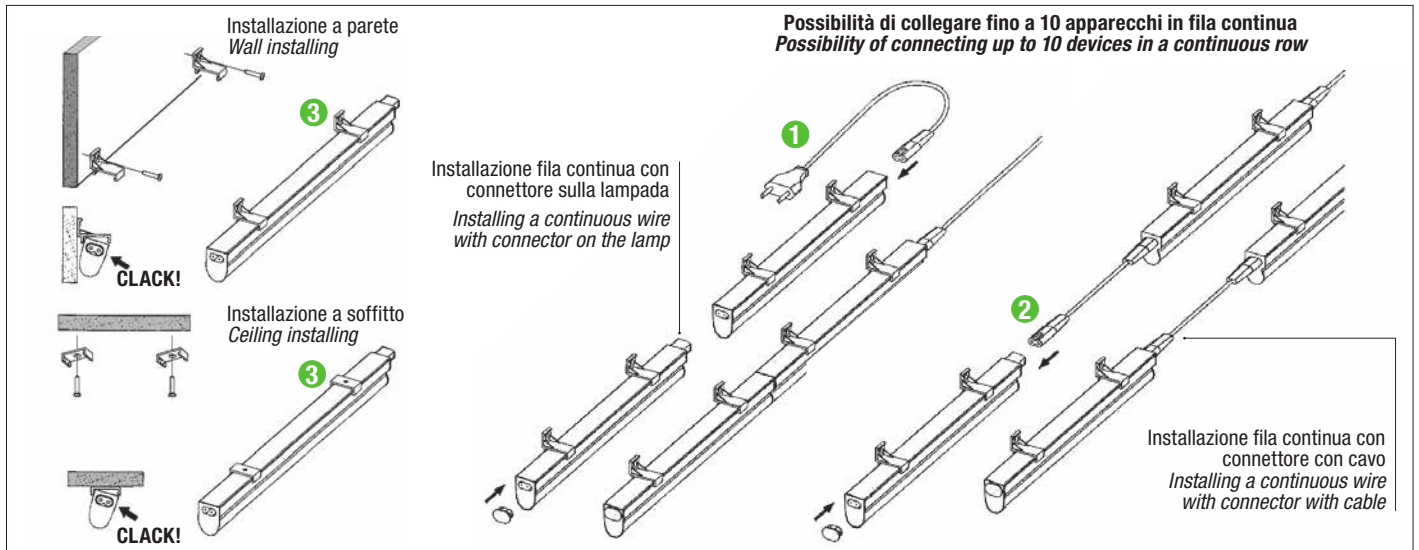

# ILLUMINAZIONE DI SICUREZZA - SAFETY LIGHTING

La gamma di lampade di emergenza Relco è creata per garantire l'illuminazione in caso di black-out, aumentando il livello di sicurezza in ogni ambiente.

Perfette per ogni tipo di abitazione, rispondono alla Norma CEI 64-8 che esige l'installazione di lampade ad accensione automatica in caso di mancanza di illuminazione ordinaria.

The range of Relco emergency lamps are created to ensure lighting in the event of a blackout, increasing the level of safety in any environment.

Perfect for any type of home, they comply with the CEI 64-8 standard which requires the installation of lamps with automatic switch-on in the event of a lack of ordinary lighting.



## Technical data

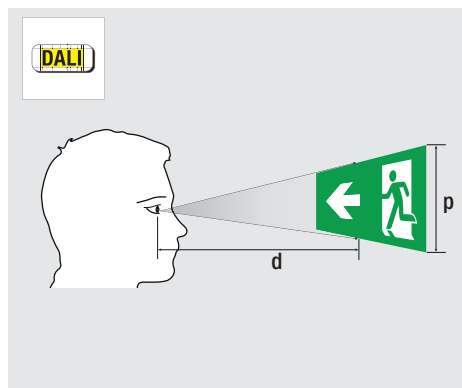

Pag. 496

## Control Panel



Pag. 499

## Router



Pag. 499

## Osiride emergenza Autotest



Pag. 500

## Osiride segnalazione Autotest



Pag. 502

## Spot Emer SE 3h Autotest



Pag. 504

## Raja W-C-R Autotest



Pag. 508

## Orione



Pag. 510

## Sirio Autotest



Pag. 514

## Venere Autotest



Pag. 516

## Accessori Sirio - Venere

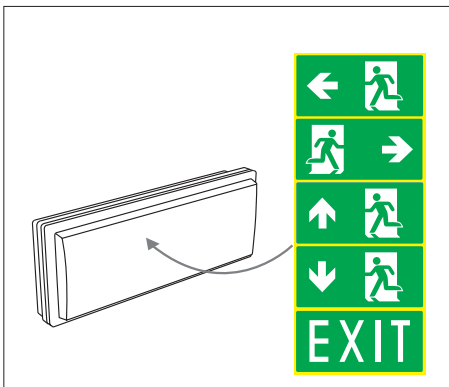

Pag. 518

## AT Autotest



Pag. 520

## Spot Emer SE 3h Autotest



Pag. 522

## Cuculo



Pag. 524

## Keyemer



Pag. 526

## Come scegliere l'illuminazione di Sicurezza - How to choose Safety lighting

La direzione delle vie di fuga e le uscite devono essere riconoscibili tramite la segnaletica e l'illuminazione di sicurezza: queste variano secondo la concentrazione di persone, il numero di piani, la posizione, l'estensione e l'uso degli edifici, secondo gli impianti o i compartimenti antincendio.

The direction of the escape route and the exits must be recognizable through safety signs and lighting: these vary according to the concentration of people, the number of floors, the location, extension and use of the buildings, according to the fire systems or compartments.

### Posizionamento delle lampade di emergenza

A) **La direzione delle vie di fuga** deve essere opportunamente contrassegnata nel caso non sia immediatamente visibile o se l'ambiente è frequentato da persone che non hanno confidenza con la geometria del luogo (ad esempio scale, corridoi, cambi di direzione).

### Positioning of emergency lamps

A) The direction of the escape route must be suitably marked if it is not immediately visible or if the room is frequented by people who are not familiar with the geometry of the place (for example stairs, corridors, changes of direction).

B) **Vanno contrassegnate** le uscite che non siano immediatamente identificabili come tali o che vengano usate solo in caso di emergenza.

B) Exits that are not immediately identifiable as such or that are only used in an emergency must be marked.

C) **La segnaletica deve essere** facilmente riconoscibile e posizionata in modo tale che chiunque, da qualsiasi posizione nel locale, possa individuare almeno un pittogramma segnaletico.

C) The signs must be easily recognizable and positioned in such a way that anyone, from any position in the room, can identify at least one sign pictogram.





D) **La segnaletica delle vie di fuga** e delle uscite deve essere installata in modo unitario all'interno di un unico edificio.

D) Signage of escape routes and exits must be installed in a uniform way within a single building.



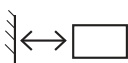

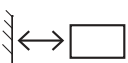
E) **La segnaletica per identificare le vie di fuga** e le uscite va collocata in posizione trasversale rispetto alla direzione da seguire, in modo tale che in caso di incendio non venga prematuramente oscurata dal fumo ed ad almeno 0.5 m dal soffitto in ambienti dove è rilevante la presenza di fumo in caso di incendio (CIE S 020/E).

E) The signs to identify escape routes and exits must be placed in a transverse position with respect to the direction to be followed, so that in the event of a fire it is not prematurely obscured by smoke and at least 0.5 m from the ceiling in environments where there is a significant presence of smoke in the event of a fire (CIE S 020/E).

## Dati fotometrici - Photometry data (1W)

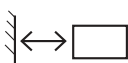
Illuminazione Area Aperta (Antipánico) (per min. 0,5 lux)			Illuminazione via di fuga (per min. 1 lux)		
Open Area (Anti-Panic) Lighting (for min. 0,5 lux)			Escape Route Lighting (for min. 1 lux)		
					
Altezza di montaggio (m) Mounting Height (m)	Distanza tra apparecchio e parete (m) Distance Between Luminaire and Wall (m)	Distanza tra gli apparecchi (m) Distance Between Luminaires (m)	Altezza di montaggio (m) Mounting Height (m)	Distanza tra apparecchio e parete (m) Distance Between Luminaire and Wall (m)	Distanza tra gli apparecchi (m) Distance Between Luminaires (m)
2,00	2,00	3,00	2,00	2,00	3,50
2,50	2,25	4,00	2,50	2,25	4,25
3,00	2,75	4,75	3,00	2,50	4,50
3,50	2,75	5,50	3,50	2,50	5,00
4,00	2,75	6,00	4,00	2,25	5,25

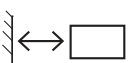
## Dati fotometrici - Photometry data (2W)

Illuminazione Area Aperta (Antipánico) (per min. 0,5 lux)			Illuminazione via di fuga (per min. 1 lux)		
Open Area (Anti-Panic) Lighting (for min. 0,5 lux)			Escape Route Lighting (for min. 1 lux)		
					
Altezza di montaggio (m) Mounting Height (m)	Distanza tra apparecchio e parete (m) Distance Between Luminaire and Wall (m)	Distanza tra gli apparecchi (m) Distance Between Luminaires (m)	Altezza di montaggio (m) Mounting Height (m)	Distanza tra apparecchio e parete (m) Distance Between Luminaire and Wall (m)	Distanza tra gli apparecchi (m) Distance Between Luminaires (m)
2,00	2,50	4,50	2,00	2,50	5
2,50	3	5,75	2,50	3	6
3,00	3,50	6,75	3,00	3,25	6,50
3,50	3,75	7,50	3,50	3,50	7
4,00	4	8	4,00	3,75	7,50

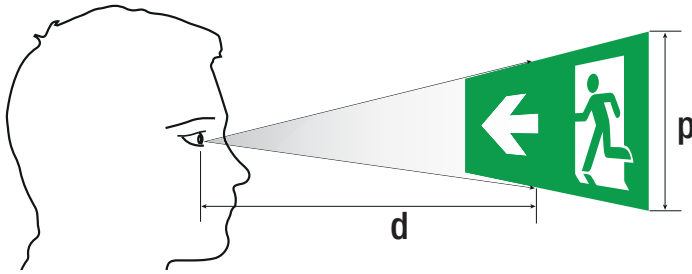

**Pittogrammi illuminati esternamente**  
Externally illuminated pictograms

Distanza di riconoscimento <b>d</b> [m] Recognition distance <b>d</b> [m]	Lunghezza laterale minima <b>p</b> [mm] Minimum lateral length <b>p</b> [mm]
15	150
20	200
35	250

**$d = s \times p$**

<b>d</b>		distanza di riconoscimento in m <i>recognition distance in m</i>
<b>p</b>		altezza del pittogramma <i>pictogram height</i>
<b>s</b>	costante <i>constant</i>	100 per pittogramma illuminato esternamente <i>100 per externally lit pictogram</i> 200 per pittogramma illuminato internamente <i>200 per internally lit pictogram</i>

**Pittogrammi retroilluminati o illuminati internamente**  
Backlit or internally lit pictograms

Distanza di riconoscimento <b>d</b> [m] Recognition distance <b>d</b> [m]	Lunghezza laterale minima <b>p</b> [mm] Minimum lateral length <b>p</b> [mm]
30	150
40	200
70	250

**Dati fotometrici - Photometry data (3W)**

Illuminazione Area Aperta (Antipanico) (per min. 0,5 lux) Open Area (Anti-Panic) Lighting (for min. 0,5 lux)			Illuminazione via di fuga (per min. 1 lux) Escape Route Lighting (for min. 1 lux)		
Altezza di montaggio (m) Mounting Height (m)	Distanza tra apparecchio e parete (m) Distance Between Luminaire and Wall (m)	Distanza tra gli apparecchi (m) Distance Between Luminaires (m)	Altezza di montaggio (m) Mounting Height (m)	Distanza tra apparecchio e parete (m) Distance Between Luminaire and Wall (m)	Distanza tra gli apparecchi (m) Distance Between Luminaires (m)
2,00	3,00	5,50	2,00	3,00	5,75
2,50	3,50	6,75	2,50	3,50	7,00
3,00	4,00	7,75	3,00	4,00	7,75
3,50	4,25	8,50	3,50	4,25	8,50
4,00	4,50	9,25	4,00	4,25	9,25

**Dati fotometrici - Photometry data (5W)**

Illuminazione Area Aperta (Antipanico) (per min. 0,5 lux) (Lente simmetrica) Open Area (Anti-Panic) Lighting (for min. 0,5 lux) (Symmetric Lens)			Illuminazione via di fuga (per min. 1 lux) Escape Route Lighting (for min. 1 lux)		
Altezza di montaggio (m) Mounting Height (m)	Distanza tra apparecchio e parete (m) Distance Between Luminaire and Wall (m)	Distanza tra gli apparecchi (m) Distance Between Luminaires (m)	Altezza di montaggio (m) Mounting Height (m)	Distanza tra apparecchio e parete (m) Distance Between Luminaire and Wall (m)	Distanza tra gli apparecchi (m) Distance Between Luminaires (m)
2,00	3,50	7	2,00	3,50	7
2,50	4	8,50	2,50	4	8,75
3,00	4,50	9,50	3,00	5	9,50
3,50	5,25	10,50	3,50	5,25	10,50
4,00	5,50	11,25	4,00	5,50	11,50



# EMERGENCY EXIT LUMINAIRES - LED CONTROLLER DALI

## DALI

Digital Addressable Lighting Interface (DALI) è un protocollo di comunicazione aperto sviluppato dai principali produttori nel settore dell'illuminazione ed è definito nello standard tecnico internazionale IEC 62386.

Il protocollo DALI, che è stato sviluppato inizialmente per i sistemi di illuminazione controllabili, al momento include molte tecnologie di illuminazione intelligenti e i requisiti per l'illuminazione di emergenza sono inclusi nell'ambito dello standard. Fornisce la massima flessibilità e facilità per progettisti di sistemi, società di progettazione/installazione/montaggio e utenti finali ed è una piattaforma di comunicazione molto sicura e stabile per l'illuminazione di emergenza, per il monitoraggio delle luci di emergenza in conformità con il regolamento sulla protezione antincendio degli edifici e la norma EN / IEC 50172.

In qualità di membro attivo dell'organizzazione DALI, Relco progetta e produce prodotti e sistemi di illuminazione di emergenza conformi allo standard DALI.

Nel nostro laboratorio di ricerca e sviluppo, progetti di circuiti originali e software integrato vengono sviluppati per unità di illuminazione di emergenza conformi a DALI e apparecchi per uscite di emergenza. Con l'utilizzo di nuove tecnologie, la nostra famiglia di prodotti che produciamo nei nostri stabilimenti viene ulteriormente ampliata. Relco, in qualità di membro dell'organizzazione DiiA che regola gli standard DALI, garantisce la conformità DALI dei suoi prodotti con il ProbitLab - DALI Tester nel suo laboratorio di ricerca e sviluppo. Relco, come membro di DiiA, applica il logo DALI ai suoi prodotti che superano tutti i test con successo.

Digital Addressable Lighting Interface (DALI) is an open communication protocol developed by the leading producers in the lighting industry and is defined in international IEC 62386 technical standard.

DALI protocol, which was developed for controllable lighting ballasts at the beginning, includes many smart lighting technologies at the moment and requirements for Emergency Lighting is included in scope of the standard. It provides maximum flexibility and easiness for system designers, project/installation/montage firms and final users and a very secure and stable communication platform for emergency lighting for monitoring emergency lights in compliance with the Regulation on Fire Protection of Buildings and EN / IEC 50172 Standard.

As an active member of DALI organization, Relco designs and manufactures DALI compliant emergency lighting products and systems.

In our R&D laboratory, original circuit designs and embedded software are developed for DALI compliant emergency lightings units and emergency exit luminaires. With using new technologies; our product family which we manufacture in our facilities is further expanded. Relco, as a member of the DiiA organization regulates DALI standards, warrants the DALI compliance of its products with the ProbitLab - DALI Tester in its R & D Laboratory. Relco, as a member of DiiA, it applies the DALI logo to its products that pass all tests successfully.

## WIRED MONITORING SYSTEM

è la nostra soluzione di sistema di monitoraggio cablato che consente di monitorare lo stato dei prodotti di illuminazione di emergenza compatibili DALI tramite router e pannello touch screen

- Monitoraggio centralizzato tramite pannello di controllo touch screen
- Sistema di illuminazione di emergenza indirizzabile secondo gli standard EN e IEC
- Test funzionali e di autonomia istantanei o periodici
- Software di controllo per test, reporting e registrazione dei rapporti di test
- Interfaccia utente protetta da password
- Cablaggio bus dati standard DALI omnidirezionale e a 2 fili

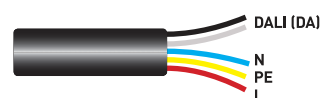
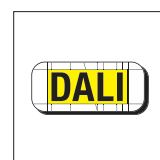

is our wired monitoring system solution that allows you to monitor status of DALI compatible emergency lighting products via router and touch screen panel.

- Central monitoring via touch screen control panel
- Addressable emergency lighting system according to EN and IEC standards
- Instant or periodic functional and duration tests
- Control software for testing, reporting and recording test reports
- Password protected user interface
- Omnidirectional and 2-wired standard DALI data bus cabling



# EMERGENCY EXIT LUMINAIRES - LED CONTROLLER DALI

## MONITORING AND CONTROL PANEL



### CONTROL PANEL - Codice R00326

- RTC (orologio in tempo reale).
- Schermo tattile da 7 pollici.
- 1x Ethernet RJ45: Internet TCP/IP.
- 1 ingresso RS485: per il collegamento di 16 router DALI (max. 2048 dispositivi di illuminazione di emergenza conformi a DALI).
- 230VAC 50/60Hz
- Test funzionali e di autonomia dei dispositivi di illuminazione di emergenza DALI compliant.
- Monitoraggio dello stato della batteria e della lampada LED.
- Segnalazione e registrazione dei risultati dei test

### CONTROL PANEL - Code R00326

- RTC (Real Time Clock).
- 7 inch touch screen.
- 1x RJ45 Ethernet : TCP/IP Internet.
- 1x RS485 input: for 16 x DALI Router connection (max. 2048 DALI compliant emergency lighting device)
- 230VAC 50/60 Hz
- Functional and duration tests of DALI compliant emergency lighting devices.
- Status Monitoring of battery and LED lamp
- Reporting and recording test results



### ROUTER - Codice R00327

- 2 uscite: max. 128 connessioni per dispositivi di illuminazione di emergenza conformi a DALI.
- 1 ingresso RS485: per il collegamento del pannello di controllo touch screen.
- 230VAC 50/60Hz

### ROUTER - Code R00327

- 2x Outputs: Max. 128 x DALI compliant emergency lighting device connection.
- 1x RS485 input: For connection of touch screen control panel.
- 230VAC 50/60Hz

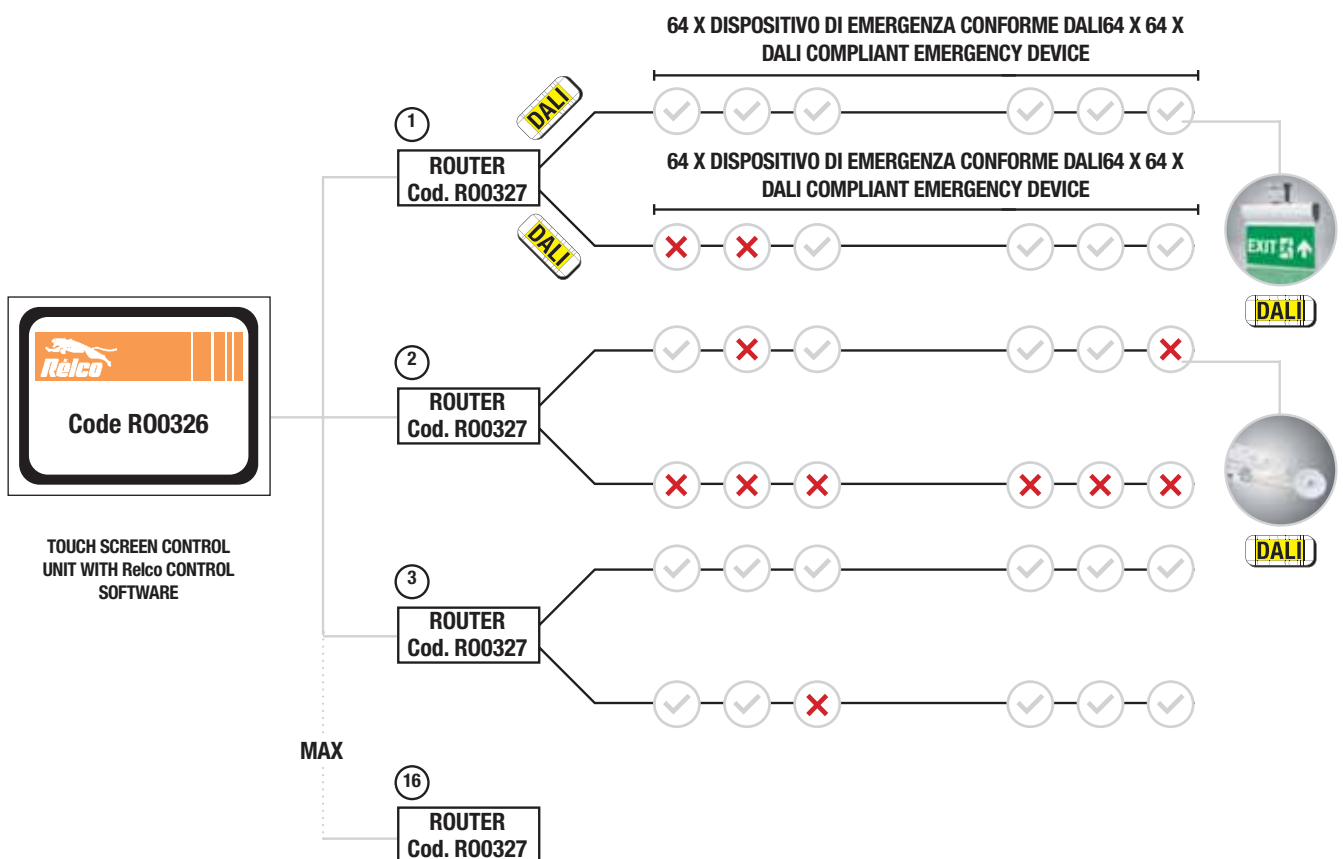

DALI

Controller DALI

**AUTOTEST**

# EMERGENCY LIGHTING LUMINAIRES - LED

## OSIRIDE Emergenza Dali Autotest

<b>Potenza*:</b>	1W (6W*) - 3W (18W*)
<b>Temperatura colore:</b>	6000K
<b>Alimentazione:</b>	230V~, 110V~ a richiesta.
<b>Funzionamento:</b>	SA (Sempre accesa) - SE (Solo Emergenza)
<b>Conforme alle norme:</b>	EN60598-1; EN60598-2-2; EN60598-2-22; EN62471; EN62031; EN61347-1; EN61347-2-13; EN 62386
<b>Grado di protezione:</b>	IP65
<b>Inibizione:</b>	Via DALI
<b>Autonomia:</b>	3h
<b>Temperatura ambiente:</b>	-5 °C ÷ +40 °C.
<b>Installazioni:</b>	Soffitto, parete.
<b>Alimentatore:</b>	driver elettronico a corrente costante.
<b>Corpo:</b>	Polycarbonato bianco RAL 9003.
<b>Sorgente:</b>	Modulo LED
<b>Ottica:</b>	Simmetrica
<b>Schermo:</b>	Polycarbonato trasparente

<b>Power*:</b>	1W (6W*) - 3W (18W*)
<b>Kelvin temperature:</b>	6000K
<b>Current:</b>	230V~, 110V~ on request.
<b>Functioning:</b>	M (Maintained) - N/M (Non-Maintained)
<b>According to standard:</b>	EN60598-1; EN60598-2-2; EN60598-2-22; EN62471; EN62031; EN61347-1; EN61347-2-13; EN 62386
<b>IP Degree:</b>	IP65
<b>Inibition:</b>	Via DALI
<b>Autonomy:</b>	3h
<b>Operating ambient temperature:</b>	-5 °C ÷ +40 °C.
<b>Installation:</b>	Ceiling, wall.
<b>Driver:</b>	Electronic constant current driver.
<b>Body:</b>	White polycarbonate RAL 9003.
<b>Light source:</b>	LED module
<b>Optic:</b>	Simmetrical
<b>Shield:</b>	Transparent polycarbonate

\* Potenza indicativa per il confronto con tubo fluorescente (a parità di lumen prodotti).

\* Power indicative by comparison with fluorescent tube (at the same produced lumen)



Uso interno ed esterno, corpo e vetro in polycarbonato.  
 A prova di umidità. Lunga durata (50.000 ore).  
 Funzione di illuminazione di emergenza mediante interruzione della fase non commutata.  
 Funzione di illuminazione di emergenza in caso di bassa tensione.  
 Durata 3 ore in caso di emergenza.  
 Indicatore di stato con LED verde / rosso.  
 Interruttore di prova.  
 Controllo remoto e test con interfaccia DALI.  
 Celle della batteria Ni-Cd ad alta temperatura.  
 Protezione da sovraccarico e scarica profonda.  
 A soffitto, incasso a soffitto o a parete.  
 Opzionale - Compatibilità 110 VAC.  
 Opzionale - Applicazione batteria LiFePO4 o Ni-MH.

*Indoor and outdoor use.  
 Polycarbonate case and glass.  
 Moisture-proof. Long life-time (50.000 hours).  
 Emergency lighting function by interruption of the unswitched phase.  
 Emergency lighting function in case of low-voltage.  
 3 hours duration in case of emergency.  
 Status display with green /red LEDs.  
 Test switch.  
 Remote control and test with DALI interface.  
 High-temperature Ni-Cd battery cells.  
 Overcharge and deep discharge protection.  
 Ceiling mounted, ceiling recessed or wall mounted.  
 Optional - 110 VAC compatibility.  
 Optional - LiFePO4 or Ni-MH battery application.*

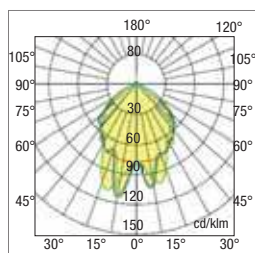
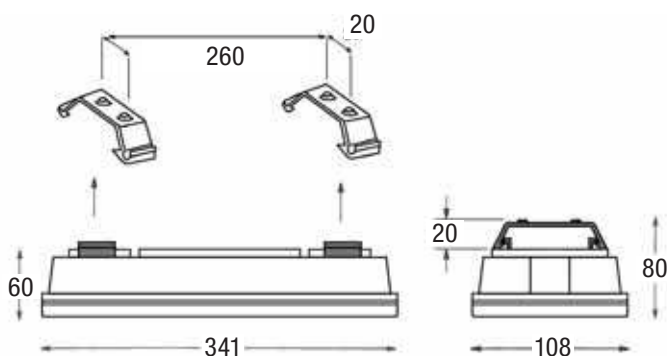
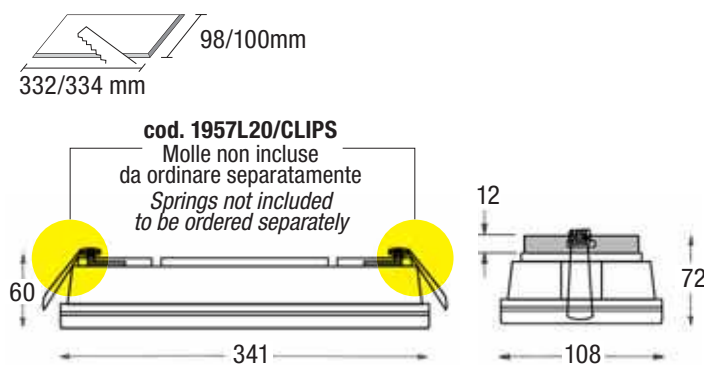
**Dati fotometrici**  
**Photometric data**
**DISEGNI TECNICI - MONTAGGIO A PLAFONE**  
**TECHNICAL DRAWING - SURFACE MOUNTED**

**DISEGNI TECNICI - MONTAGGIO AD INCASSO**  
**TECHNICAL DRAWING - RECESSED MOUNTED**

LED Safety Lighting

Conforme alle norme EN 60598-1, EN 60598-2-22, EN 62386.  
In accordance with EN 60598-1, EN 60598-2-22, EN 62386 standards.



## LED Osiride Emergenza AUTOTEST

Descrizione Description	Potenza* Power W	Versione Version	Autonomia Autonomy h.	Inibizione Inhibition Via DALI	Batteria Battery Ni-Cd		Ricarica Recharge h.	Flusso medio Average flow		n°LED	Assorb. max Absorpt. max		Pcs	Codice Code
					Voit	Ah		SE lm	SA lm		SE W	SA W		
OSIRIDE IP65 24 SA 3H AT D	1W (6W*)	SA **	3	SI	3,6	1,6	24	-	115	20		5,05		1957L20SAREL
OSIRIDE IP65 24 SE 3H AT D	3W (18W*)	SE ***	3	SI	3,6	4	24	-/350	-	20	2,6			1957L20SEREL

\*Potenza indicativa per il confronto con tubo fuorescente (a parità di lumen prodotti) / Power indicative by comparison with fluorescent tube (at the same produced lumen).

\*\* Sempre accesa / always on

\*\*\* Si illumina in caso di mancanza di rete / Lights in case of the mains failure.

### Schema elettrico - Wiring diagram

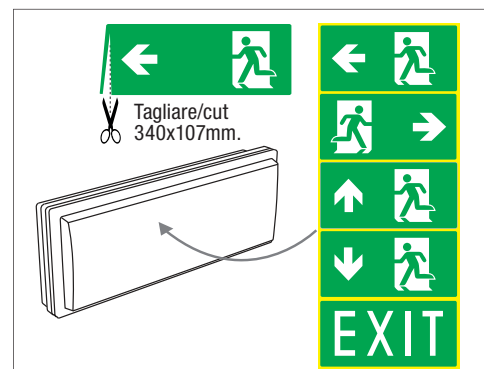
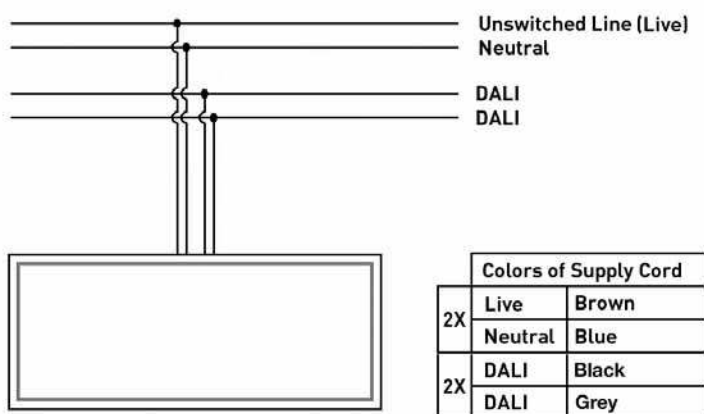

Codice Code	Descrizione Description	DV* (m)
<b>R00322</b>	5 segnali di sicurezza 5 safety signs	22

\*DV=Distanza di visibilità in metri - Visibility distance in meter

**DIMENSIONI PITTOGRAMMA  
SIGN DIMENSIONS** 340 x 120 mm

**DISTANZA DI VISIONE  
VIEWING DISTANCE** 22 m

### Accessori non inclusi - Not included accessoires

Codice/Code	Descrizione/Description
<b>R00322</b>	5 segnali di sicurezza (adesivi) - 5 safety signs (adhesives).
<b>1957L20/CLIPS</b>	Molle di fissaggio per installazione ad incasso - Fixing springs for recessed installation

### Indicatore LED bicolore Autodiagnosi - bicoloured LED indicator Autotest

	VERDE permanente Permanent GREEN	Modalità di ricarica	Charge mode
	VERDE lampeggiante veloce (0,1s acceso - 0,1s spento) Fast flashing GREEN (0,1s on - 0,1s off)	Test di funzionalità	Function test
	VERDE lampeggiante lento (1s acceso - 1s spento) Slow flashing GREEN (1s on - 1s off)	Prova di durata	Duration test
	ROSSO permanente Permanent RED	Errore di carico	Load failure
	ROSSO lampeggiante lento (1s acceso - 1s spento) Slow flashing RED (1s on - 1s off)	Guasto della batteria	Battery failure
	ROSSO lampeggiante veloce (0,1s acceso - 0,1s spento) Fast flashing RED (0,1s on - 0,1s off)	Errore di ricarica	Charging failure
	Doppia lampeggio VERDE Double pulsing GREEN	Modalità inibizione	Inhibit mode
	Trasmissione binaria dell'indirizzo via VERDE/ROSSO Binary transmission of address via GREEN/RED	Indirizzamento o identificazione	Addressing or identification
	VERDE e ROSSO spenti GREEN and RED off	Modalità di emergenza	Emergency mode

### Test funzioni interruttore - Test switch function

Pressione breve (<1s) Short press (<1s)	Avvia il test di funzionalità o termina tutti i test.	Starts the function test or terminate the all tests.
Pressione lunga (>5s) Long press (>5s)	Test di durata	Starts the duration test.

DALI

AUTOTEST

## EMERGENCY EXIT LUMINAIRES - LED

## OSIRIDE Segnalazione Dali Autotest

<b>Potenza*:</b>	1W (6W*)	<b>Power*:</b>	1W (6W*)
<b>Temperatura colore:</b>	6000K	<b>Kelvin temperature:</b>	6000K
<b>Alimentazione:</b>	230V~, 110V~ a richiesta.	<b>Current:</b>	230V~, 110V~ on request.
<b>Funzionamento:</b>	SA (Sempre accesa)	<b>Functioning:</b>	M (Maintained)
<b>Conforme alle norme:</b>	EN60598-1; EN60598-2-2; EN60598-2-22; EN62471; EN62031; EN61347-1; EN61347-2-13; EN 62386	<b>According to standard:</b>	EN60598-1; EN60598-2-2; EN60598-2-22; EN62471; EN62031; EN61347-1; EN61347-2-13; EN 62386
<b>Grado di protezione:</b>	IP20	<b>IP Degree:</b>	IP20
<b>Inibizione:</b>	Via DALI	<b>Inibition:</b>	Via DALI
<b>Autonomia:</b>	3h	<b>Autonomy:</b>	3h
<b>Temperatura ambiente:</b>	0 °C ÷ +40 °C.	<b>Operating ambient temperature:</b>	0 °C ÷ +40 °C.
<b>Installazioni:</b>	Soffitto, parete.	<b>Installation:</b>	Ceiling, wall.
<b>Alimentatore:</b>	driver elettronico a corrente costante.	<b>Driver:</b>	Electronic constant current driver.
<b>Corpo:</b>	Policarbonato bianco RAL 9003.	<b>Body:</b>	White polycarbonate RAL 9003.
<b>Sorgente:</b>	Modulo LED	<b>Light source:</b>	LED module
<b>Ottica:</b>	-	<b>Optic:</b>	-
<b>Schermo:</b>	Policarbonato trasparente	<b>Shield:</b>	Transparent polycarbonate

\* Potenza indicativa per il confronto con tubo fluorescente (a parità di lumen prodotti).

\* Power indicative by comparison with fluorescent tube (at the same produced lumen)

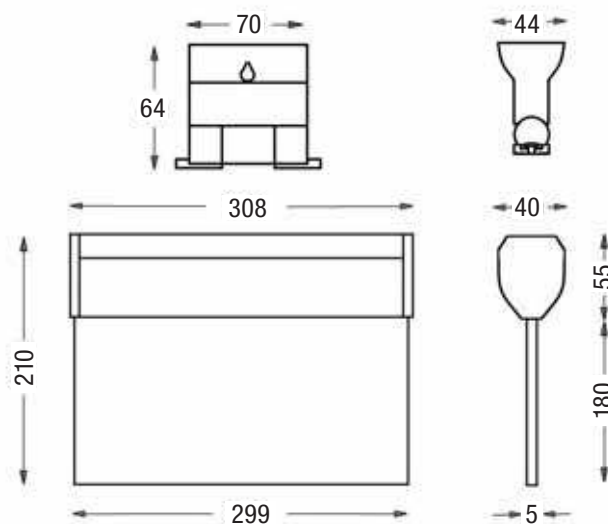

Monofacciale o bifacciale.  
Cassa in alluminio anodizzato.  
Copertura laterale e gancio in policarbonato.  
Applicazione LED SMD.  
Indicatore di stato con LED verde/rosso.  
Interruttore di prova.  
Controllo remoto e test con interfaccia DALI.  
Celle della batteria Ni-Cd ad alta temperatura.  
Protezione da sovraccarico e scarica profonda.  
Plexiglas trasparente con serigrafia.  
Illuminazione laterale.  
A soffitto, incasso a soffitto o a parete.

**OPZIONALE**

Compatibilità 110 VAC.  
Applicazione batteria LiFePO<sub>4</sub> o Ni-MH.

Single- or double-sided  
Anodized aluminum case  
Polycarbonate side cover and hanger  
SMD LED application  
Status display with green/red LED  
Test switch  
Remote control and test with DALI interface  
High-temperature Ni-Cd battery cells  
Overcharge and deep discharge protection  
Transparent Plexiglas with screen printed  
Side lighting  
Ceiling mounted, ceiling recessed or wall mounted.

**OPTIONAL**

110 VAC compatibility  
LiFePO<sub>4</sub> or Ni-MH battery application

Conforme alle norme EN 60598-1, EN 60598-2-22, EN 62386.  
In accordance with EN 60598-1, EN 60598-2-22, EN 62386 standards.



## LED Osiride Segnalazione AUTOTEST

Descrizione Description	Potenza* Power W	Versione Version	Autonomia Autonomy h.	Inibizione Inhibition Via DALI	Batteria Battery Ni-Cd		Ricarica Recharge h.	Flusso medio Average flow SA lm	n°LED	Assorb. max Absorpt. max SA W	Pcs	Codice Code
					Volt	Ah						
OSIRIDE S IP20 24 SA 3H AT D EX	1W (6W*)	SA **	3	SI	3,6	1,6	24	115	12	4,82	1	1957L12SAREEX
OSIRIDE S IP20 24 SA 3H AT D SX	1W (6W*)	SA **	3	SI	3,6	1,6	24	115	12	4,82	1	1957L12SARESX
OSIRIDE S IP20 24 SA 3H AT D DX	1W (6W*)	SA **	3	SI	3,6	1,6	24	115	12	4,82	1	1957L12SAREDX
OSIRIDE S IP20 24 SA 3H AT D UP	1W (6W*)	SA **	3	SI	3,6	1,6	24	115	12	4,82	1	1957L12SAREUP
OSIRIDE S IP20 24 SA 3H AT D DW	1W (6W*)	SA **	3	SI	3,6	1,6	24	115	12	4,82	1	1957L12SAREDW

\*Potenza indicativa per il confronto con tubo fluorescente (a parità di lumen prodotti)  
Power indicative by comparison with fluorescent tube (at the same produced lumen).

\*\* Sempre accesa / always on

### Schema elettrico - Wiring diagram

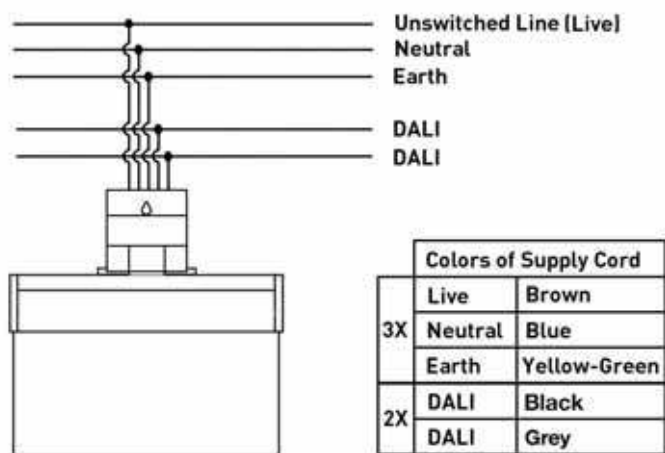

### SCELTA SEGNALETICA SIGNAL CHOICE



### DIMENSIONI PITTOGRAMMA SIGN DIMENSIONS

180 x 299 mm

### DISTANZA DI VISIONE VIEWING DISTANCE

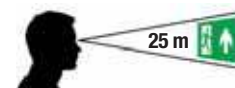

### CLASSE DI PROTEZIONE PROTECTION CLASS CLASSE DI ISOLAMENTO INSULATION CLASS

IP 20  
I

### Indicatore LED bicolore Autodiagnosi - bicoloured LED indicator Autotest

	VERDE permanente Permanent GREEN	Modalità di ricarica	Charge mode
	VERDE lampeggiante veloce (0,1s acceso - 0,1s spento) Fast flashing GREEN (0,1s on - 0,1s off)	Test di funzionalità	Function test
	VERDE lampeggiante lento (1s acceso - 1s spento) Slow flashing GREEN (1s on - 1s off)	Prova di durata	Duration test
	ROSSO permanente Permanent RED	Errore di carico	Load failure
	ROSSO lampeggiante lento (1s acceso - 1s spento) Slow flashing RED (1s on - 1s off)	Guasto della batteria	Battery failure
	ROSSO lampeggiante veloce (0,1s acceso - 0,1s spento) Fast flashing RED (0,1s on - 0,1s off)	Errore di ricarica	Charging failure
	Doppia lampeggio VERDE Double pulsing GREEN	Modalità inibizione	Inhibit mode
	Trasmissione binaria dell'indirizzo via VERDE/ROSSO Binary transmission of address via GREEN/RED	Indirizzamento o identificazione	Addressing or identification
	VERDE e ROSSO spenti GREEN and RED off	Modalità di emergenza	Emergency mode

### Test funzioni interruttore - Test switch function

Pressione breve (<1s) Short press (<1s)	Avvia il test di funzionalità o termina tutti i test.	Starts the function test or terminate the all tests.
Pressione lunga (>5s) Long press (>5s)	Test di durata	Starts the duration test.

**AUTOTEST**

# EMERGENCY LUMINAIRES LUMINAIRES - LED

## LED SPOT Emer Dali SE3W Autotest

<b>Potenza*:</b>	3W (18W*)
<b>Temperatura colore:</b>	6000K
<b>Alimentazione:</b>	230V~, 110V~ a richiesta.
<b>Funzionamento:</b>	SE (Solo Emergenza).
<b>Conforme alle norme:</b>	EN60598-1; EN60598-2-2; EN60598-2-22; EN62471; EN62031; EN61347-1; EN61347-2-13; EN 62386
<b>Grado di protezione:</b>	IP20
<b>Inibizione:</b>	Via DALI
<b>Autonomia:</b>	3h
<b>Temperatura ambiente:</b>	0 °C ÷ +40 °C.
<b>Installazioni:</b>	Incasso controsoffitto.
<b>Alimentatore:</b>	driver elettronico a corrente costante.
<b>Corpo:</b>	Policarbonato bianco RAL 9003.
<b>Sorgente:</b>	Modulo LED
<b>Ottica:</b>	corridoio e diffondente
<b>Schermo:</b>	Policarbonato trasparente

<b>Power*:</b>	3W (18W*)
<b>Kelvin temperature:</b>	6000K
<b>Current:</b>	230V~, 110V~ on request.
<b>Functioning:</b>	N/M (Non-Maintained).
<b>According to standard:</b>	EN60598-1; EN60598-2-2; EN60598-2-22; EN62471; EN62031; EN61347-1; EN61347-2-13; EN 62386
<b>IP Degree:</b>	IP20
<b>Inibition:</b>	Via DALI
<b>Autonomy:</b>	3h
<b>Operating ambient temperature:</b>	0 °C ÷ +40 °C.
<b>Installation:</b>	Recessed false ceiling.
<b>Driver:</b>	Electronic constant current driver.
<b>Body:</b>	White polycarbonate RAL 9003.
<b>Light source:</b>	LED module
<b>Optic:</b>	Corridor and diffusing
<b>Shield:</b>	Transparent polycarbonate

\* Potenza indicativa per il confronto con tubo fluorescente (a parità di lumen prodotti).

\* Power indicative by comparison with fluorescent tube (at the same produced lumen)

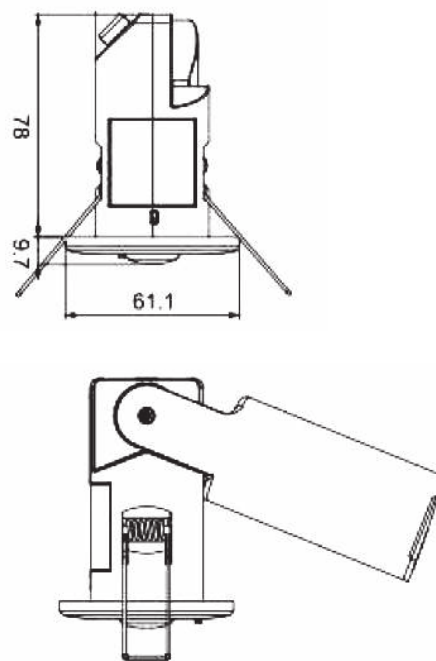

Apparecchio di illuminazione di emergenza indipendente con interfaccia Dali e test automatico.

Modulo di emergenza a LED adatto per l'installazione diretta a soffitto. Set completo con elettronica integrata, modulo LED, custodia e batteria.

Luce di emergenza spot da incasso con lente per area aperta e corridoio.

Alimentatore bus DALI integrato.

Policarbonato bianco RAL 9016.

Pacco batterie LiFePO4 integrato.

Perdita di potenza in stand-by molto bassa.

Modalità non permanente.

SELV.

Filo incandescente 850°.

2 anni di garanzia parte elettronica.

Batteria con garanzia di 4 anni.

Independent emergency lighting fixture with Dali interface and automatic test function. LED emergency module suitable for direct installation in ceilings.

Complete set with integrated electronics, LED module, housing, and battery.

Recessed spot emergency light with open area and corridor lens.

Integrated DALI bus power supply.

Polycarbonate white RAL 9016.

Integral LiFePO4 battery pack.

Very low stand-by power loss.

Non-maintained mode.

SELV output voltage.

850°Glow-wire.

2 years guarantee electronic.

4-year guarantee battery.

Conforme alle norme EN 60598-1, EN 60598-2-22, EN 62386.  
 In accordance with EN 60598-1, EN 60598-2-22, EN 62386 standards.



## LED Spot Emer Dali AUTOTEST

Descrizione Description	Potenza* Power W	Versione Version	Autonomia Autonomy h.	Inibizione Inhibition Via DALI	Batteria Battery LifeP04		Ricarica Recharge h.	Lumen output Lumen output		n°LED	Assorb. max Absorpt. max W	Pcs	Codice Code
					Volt	Ah		max lm	min lm				
SPOT IP20 24 SE 3H AT D	3W (18W*)	SE ***	3	SI	3,2	3	24	250	185	1	1	1	8550RELD

\*Potenza indicativa per il confronto con tubo fluorescente (a parità di lumen prodotti) / Power indicative by comparison with fluorescent tube (at the same produced lumen).

\*\*\* Si illumina in caso di mancanza di rete / Lights in case of the mains failure.

CORRIDOR LENS

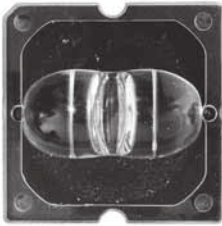

OPEN AREA LENS

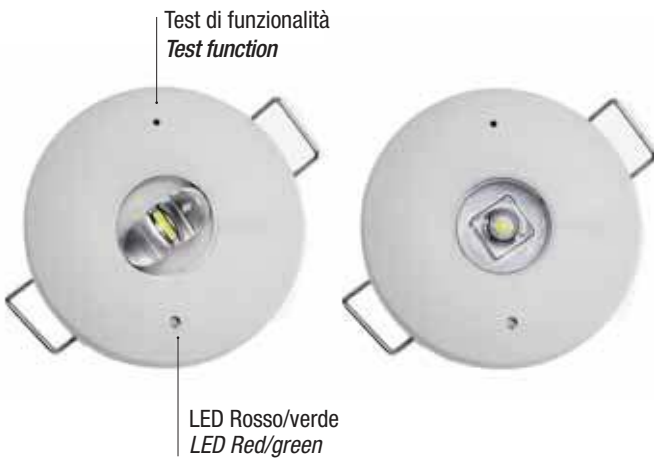

Ø min 45 - max 55

### Indicatore LED bicolore Autodiagnosi - bicoloured LED indicator Autotest

	VERDE permanente Permanent GREEN	Modalità di ricarica	Charge mode
	VERDE lampeggiante veloce (0,25s acceso - 0,25s spento) Fast flashing GREEN (0,25s on - 0,25s off)	Test di funzionalità	Function test
	VERDE lampeggiante lento (1s acceso - 1s spento) Slow flashing GREEN (1s on - 1s off)	Prova di durata	Duration test
	ROSSO permanente Permanent RED	Errore di carico	Load failure
	ROSSO lampeggiante lento (1s acceso - 1s spento) Slow flashing RED (1s on - 1s off)	Guasto della batteria	Battery failure
	ROSSO lampeggiante veloce (0,25s acceso - 0,25s spento) Fast flashing RED (0,25s on - 0,25s off)	Errore di ricarica	Charging failure
	Trasmissione binaria dell'indirizzo via VERDE/ROSSO Binary transmission of address via GREEN/RED	Indirizzamento o identificazione	Addressing or identification
	VERDE e ROSSO spenti GREEN and RED off	Modalità di emergenza	Emergency mode

### Dati della batteria - Battery Data

VOLTAGGIO VOLTAGE	CAPACITÀ CAPACITY	TIPO CELLULARE CELL TYPE	DIMENSIONE CELLA CELL SIZE (mm)	QUANTITÀ DI CELLE QTY OF CELLS	DIMENSIONI DIMENSIONS (mm)	PESO WEIGHT (g)
3.2V	3Ah (2x18650)	LiFePO4	Ø18X65mm	2	Ø18X65mm	43.3



### Dati fotometrici lente corridoio 3w - Photometry data corridor lens 3w

#### Corridor Lens

1lx

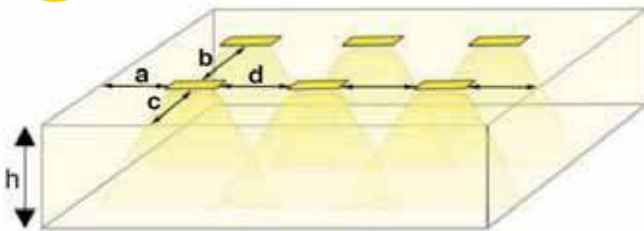

Illuminazione corridoi (per minimo 130Lm - 1 lux)  
(Lente asimmetrica)

Corridor lighting (minimum 130Lm - 1 lux)  
(Asymmetric Lens)

H (m)	a (m)	b (m)	c (m)	d (m)
2,80	8,15	2,72	7,3	20,05
3,00	8,3	2,69	7,5	20,05
4,00	8,8	2,35	7,5	22,8
5,00	8,8	1,8	7,0	24,2
6,00	5,3	1,3	6,0	24,9

### Curva di distribuzione della luce (lente corridoio) - Light distribution curve (corridor lens).

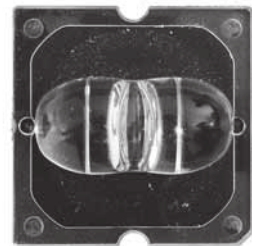
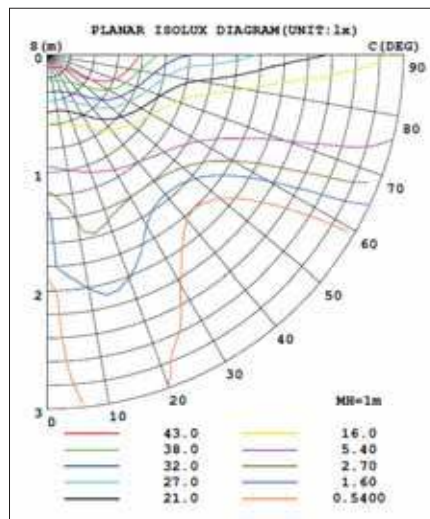
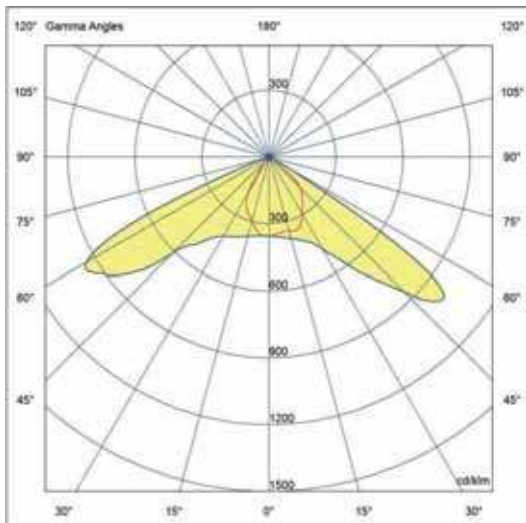

LENTE per CORRIDOIO  
LENTE ASIMMETRICA  
CORRIDOR LENS  
ASYMMETRIC LENS

Batteria di ricambio - *Replacement Battery*

BATTERIA DI RICAMBIO REPLACEMENT BATTERY		
Code	Type	Duration
RELCOBATT6.4V	3,2V 1500mAh LiFePO4	3h



Dati fotometrici lente diffondente 3w - *Photometry data open area lens 3w*

Open Area Lens

0,5lx

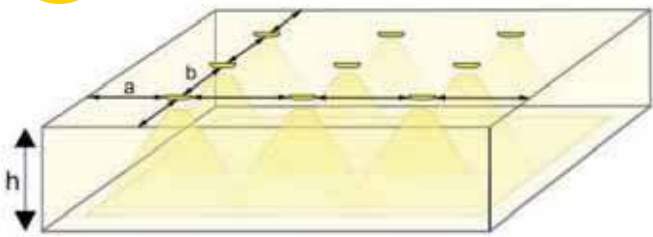

Illuminazione Area Aperta (Antipanico) (per min. 0,5 lux) (Lente simmetrica)		
Open Area (Anti-Panic) Lighting (for min. 0,5 lux) (Symmetric Lens)		
H (m)	a (m)	b(m)
2,80	6,2	15,5
3	6,3	16,1
4	6,5	17,2
5	6,6	17,7
6	6,5	18,1
7	6,3	18,2
8	5,8	18,1
9	5,1	17,8
10	3,9	17,2

Curva di distribuzione della luce (lente diffondente) - *light distribution curve (open area lens)*

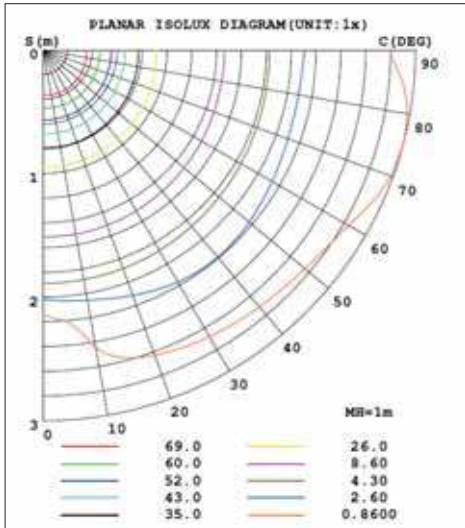
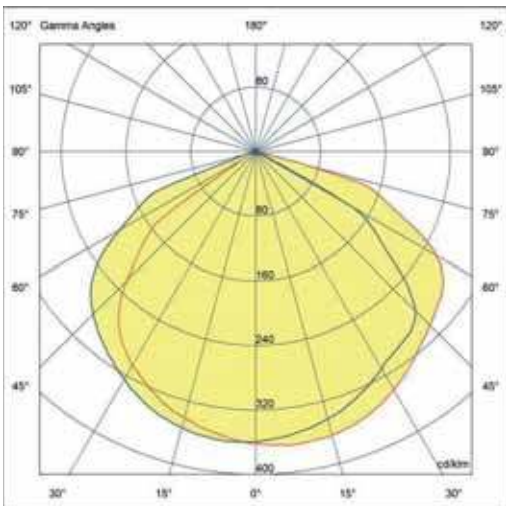

AREA APERTA  
LENTE SIMMETRICA  
OPEN AREA  
SYMMETRIC LENS



# LED Raja W-C-R Autotest

<b>Temperatura colore:</b>	6000K
<b>Alimentazione:</b>	220-240V~
<b>Funzionamento:</b>	SA (Sempre accesa) - Rest-Mode: con dispositivo opzionale (cod. R00325)
<b>Conforme alle norme:</b>	EN60598-1; EN60598-2-2; EN60598-2-22; EN62471; EN62031; EN61347-1; EN61347-2-13.
<b>Grado di protezione:</b>	IP40
<b>Inibizione:</b>	Rest mode
<b>Autonomia:</b>	3h
<b>Temperatura ambiente:</b>	-5°C ÷ +40°C.
<b>Installazioni:</b>	Soffitto, parete, parete a bandiera 90°, incasso controsoffitto.
<b>Alimentatore:</b>	driver elettronico a corrente costante.
<b>Corpo:</b>	Polycarbonato bianco RAL 9003.
<b>Sorgente:</b>	Modulo LED
<b>Ottica:</b>	Simmetrica
<b>Schermo:</b>	PMMA trasparente

<b>Kelvin temperature:</b>	6000K
<b>Current:</b>	220-240V~
<b>Functioning:</b>	M (Maintained) - Rest-Mode: with an optional device (code R00325)
<b>According to standard:</b>	EN60598-1; EN60598-2-2; EN60598-2-22; EN62471; EN62031; EN61347-1; EN61347-2-13.
<b>IP Degree:</b>	IP40
<b>Inhibition:</b>	Rest mode
<b>Autonomy:</b>	3h
<b>Operating ambient temperature:</b>	-5°C ÷ +40°C.
<b>Installation:</b>	Ceiling, wall, 90 ° flag wall, recessed false ceiling.
<b>Driver:</b>	Electronic constant current driver.
<b>Body:</b>	White polycarbonate RAL 9003.
<b>Light source:</b>	LED module
<b>Optic:</b>	Simmetrical
<b>Shield:</b>	Transparent PMMA



Raja W



Raja C

pulsante di test manuale - manual test button

Indicatore LED bicolore Autodiagnosi - bicoloured LED indicator Autotest

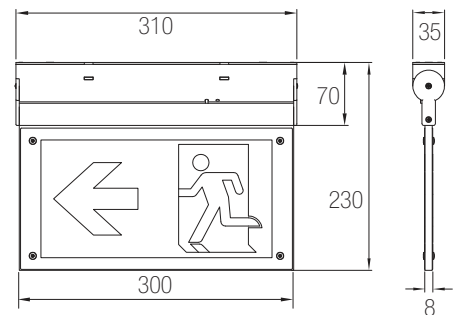

Accessori inclusi - included accessoires

DX-DESTRA - RIGHT

SX-SINISTRA - LEFT

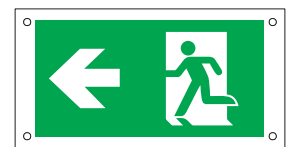
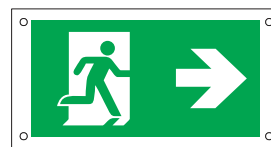

Raja R  
+ acc. cod.8500REL/I

## Accessori non inclusi - Not included accessoires

da ordinare separatamente - to be ordered separately

Codice/Code	Descrizione/Description
8500REL/U	1 Segnaletica di sicurezza bifacciale indicazione UP - Safety signs UP
8500REL/D	2 Segnaletica di sicurezza bifacciale indicazione DOWN - Safety signs DOWN
8500REL/EX	3 Segnaletica di sicurezza bifacciale indicazione EXIT - Safety signs EXIT
8500REL/I	4 Kit incasso controsoffitto - Kit recessed plasterboard
8500REL/B	5 Kit montaggio a bandiera - Side mounted Kit
8500REL/S	6 Kit montaggio sospensione - Suspension mounted Kit

### Installazione ad incasso Recessed installation



8500REL/D

### Installazione a bandiera 90° 90° flag installation



8500REL/U



8500REL/B

### Installazione a sospensione suspension installation



EXIT



8500REL/S

Segnaletica di sicurezza  
Safety signs

1 UP 8500REL/U

2 DOWN 8500REL/D

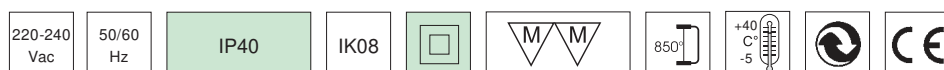
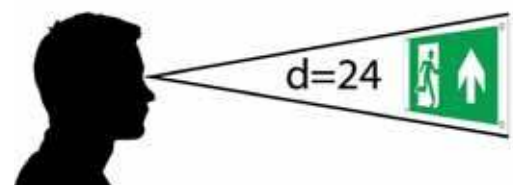

## LED Raja AUTOTEST

Descrizione Description	Potenza* Power W	Versione Version	Autonomia Autonomy h.	Batteria Battery Ni-Cd Volt Ah		Ricarica Recharge h.	Flusso medio Average flow SA lm	n°LED	Assorb. max Absorpt. max SA W	Pcs	Codice Code
RAJA IP40 11 SA 3H AT	-	SA	3	3,6	0,9	24	25	16	3	10	8500REL

## Indicatore LED bicolore Autodiagnosi - bicoloured LED indicator Autotest

	☀ Fisso - Fixed light	☀ Lampeggiante lento Slow flashed light	☀ Lampeggiante veloce fast flashed light
Verde - Green	Stato tutto ok/alimentazione presente Everything ok / power present	Test funzionale 2 min. 2 minutes functional test	Test di autonomia Autonomy test

	☀ 1 Lampeggio	☀☀ 2 Lampeggi	☀☀☀ 3 Lampeggi
Rosso - Red	Batteria guasta Battery fail	LED guasti Faulty LEDs	Durata insufficiente Insufficient autonomy



# LED Orione

<b>Potenza*:</b>	1W (6W*), 2W (11W*), 3W (18W*)	<b>Power*:</b>	1W (6W*), 2W (11W*), 3W (18W*)
<b>Temperatura colore:</b>	6000K	<b>Kelvin temperature:</b>	6000K
<b>Alimentazione:</b>	220-240V~	<b>Current:</b>	220-240V~
<b>Funzionamento:</b>	SA (Sempre accesa) - SE (Solo Emergenza)	<b>Functioning:</b>	M (Maintained) - N/M (Non-Maintained)
<b>Conforme alle norme:</b>	EN60598-1; EN60598-2-22; EN62471; EN62031; EN61347-1; EN61347-2-13.	<b>According to standard:</b>	EN60598-1; EN60598-2-2; EN60598-2-22; EN62471; EN62031; EN61347-1; EN61347-2-13.
<b>Grado di protezione:</b>	IP42	<b>IP Degree:</b>	IP42
<b>Inibizione:</b>	vedi tabella	<b>Inibition:</b>	See table
<b>Autonomia:</b>	1h, 1,5h, 2h, 3h, 5h	<b>Autonomy:</b>	1h, 1,5h, 2h, 3h, 5h
<b>Temperatura ambiente:</b>	-20 °C ÷ +40 °C.	<b>Operating ambient temperature:</b>	-20 °C ÷ +40 °C.
<b>Installazioni:</b>	Soffitto, parete.	<b>Installation:</b>	Ceiling, wall.
<b>Alimentatore:</b>	driver elettronico a corrente costante.	<b>Driver:</b>	Electronic constant current driver.
<b>Corpo:</b>	Polycarbonato bianco RAL 9003.	<b>Body:</b>	White polycarbonate RAL 9003.
<b>Sorgente:</b>	Modulo LED	<b>Light source:</b>	LED module
<b>Ottica:</b>	Simmetrica	<b>Optic:</b>	Simmetrical
<b>Schermo:</b>	Polycarbonato trasparente	<b>Shield:</b>	Transparent polycarbonate

\* Potenza indicativa per il confronto con tubo fluorescente (a parità di lumen prodotti).

\* Power indicative by comparison with fluorescent tube (at the same produced lumen)

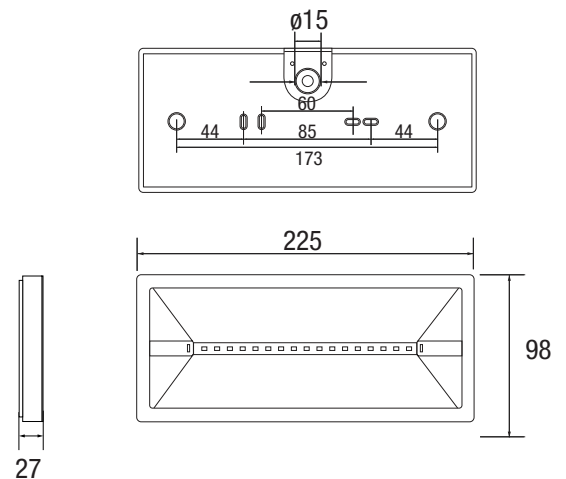
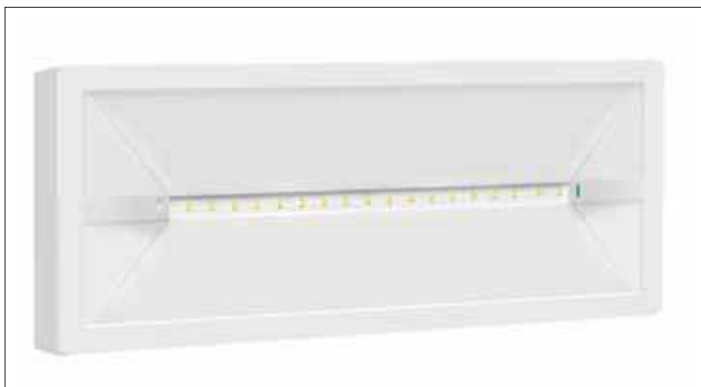

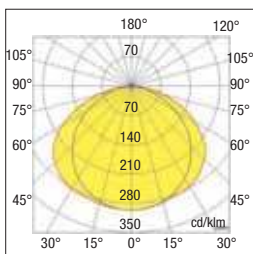

## Dati fotometrici Photometric data



## Accessori non inclusi - Not included accessories

da ordinare separatamente - to be ordered separately

	<b>Codice batteria di ricambio Code Spare battery</b>	<b>Descrizione Description</b>	<b>Riferimento modello lampada Lamp model reference</b>
	<b>00PB1500N</b>	LiFePO <sub>4</sub> 3,2V 1,5 A	1945 1947 1948 1949
	<b>00PB060</b>	LiFePO <sub>4</sub> 3,2V 0,6 A	1946

Fissaggio a soffitto  
Ceiling fixing

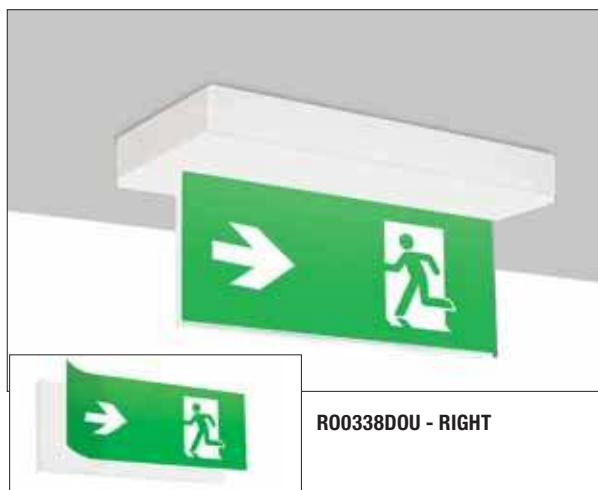

R00338DOU - RIGHT



Fissaggio a parete  
Wall fixing



R00338SIG - LEFT



LED Orione ECO

Descrizione Description	Potenza* Power W	Versione Version	Autonomia Autonomy h.	Inibizione Inhibition switch	Batteria Life P04 Battery Life P04		Ricarica Recharge h.	Flusso medio Average flow SE lm	n° LED	Assorb. max Absorpt. max SE W		Pcs	Codice Code
					Volt	Ah				SE W	SE W		
ORIONE IP42 6 SE 5H V X	1W (6W*)	SE	5	NO	3,2	1,5	12	100	8	1,6		24	1945

LED Orione

Descrizione Description	Potenza* Power W	Versione Version	Autonomia** Autonomy h.	Inibizione Inhibition switch	Batteria Life P04 Battery Life P04		Ricarica Recharge h.	Flusso medio Average flow SE lm	n° LED	Assorb. max Absorpt. max SE W		Pcs	Codice Code
					Volt	Ah				SE W	SE W		
ORIONE IP42 6 SE 1H V X	1W (6W*)	SE	1 (1,5)	NO	3,2	0,6	12	150 (100)	12	1,6		24	1946
ORIONE IP42 11 SE 2H V X	2W (11W*)	SE	2 (3)	NO	3,2	1,5	24	200 (140)	12	1,6		24	1947
ORIONE IP42 18 SE 1H V X	3W (18W*)	SE	1 (2)	NO	3,2	1,5	24	320 (200)	12	1,6		24	1948

LED Orione INHIBIT (RAPID CHARGE\*\*\*)

Descrizione Description	Potenza* Power W	Versione Version		Autonomia** Autonomy h.	Inibizione Inhibition switch	Batteria Battery Ni-Cd		Ricarica*** Recharge h.	Flusso medio Average flow		n°LED	Assorb. max Absorpt. max		Pcs	Codice Code
		SE	SA			Volt	Ah		SE lm	SA lm		SE W	SA W		
ORIONE IP42 18 SA-SE 1H V I	3W (18W*)	SE	SA	1 (3)	SI	3,2	1,5	6	400 (130)	180	18	3	4	24	1949

\*Potenza indicativa per il confronto con tubo fuorescente (a parità di lumen prodotti) - Power indicative by comparison with fluorescent tube (at the same produced lumen).

\*\*Rimuovendo il Jumper interno aumenta l'autonomia e si riduce il flusso luminoso - Removing the internal Jumper increases autonomy and reduces the light flow.

\*\*\*La carica completa avviene in sole 6 ore - Six hours complete recharge.



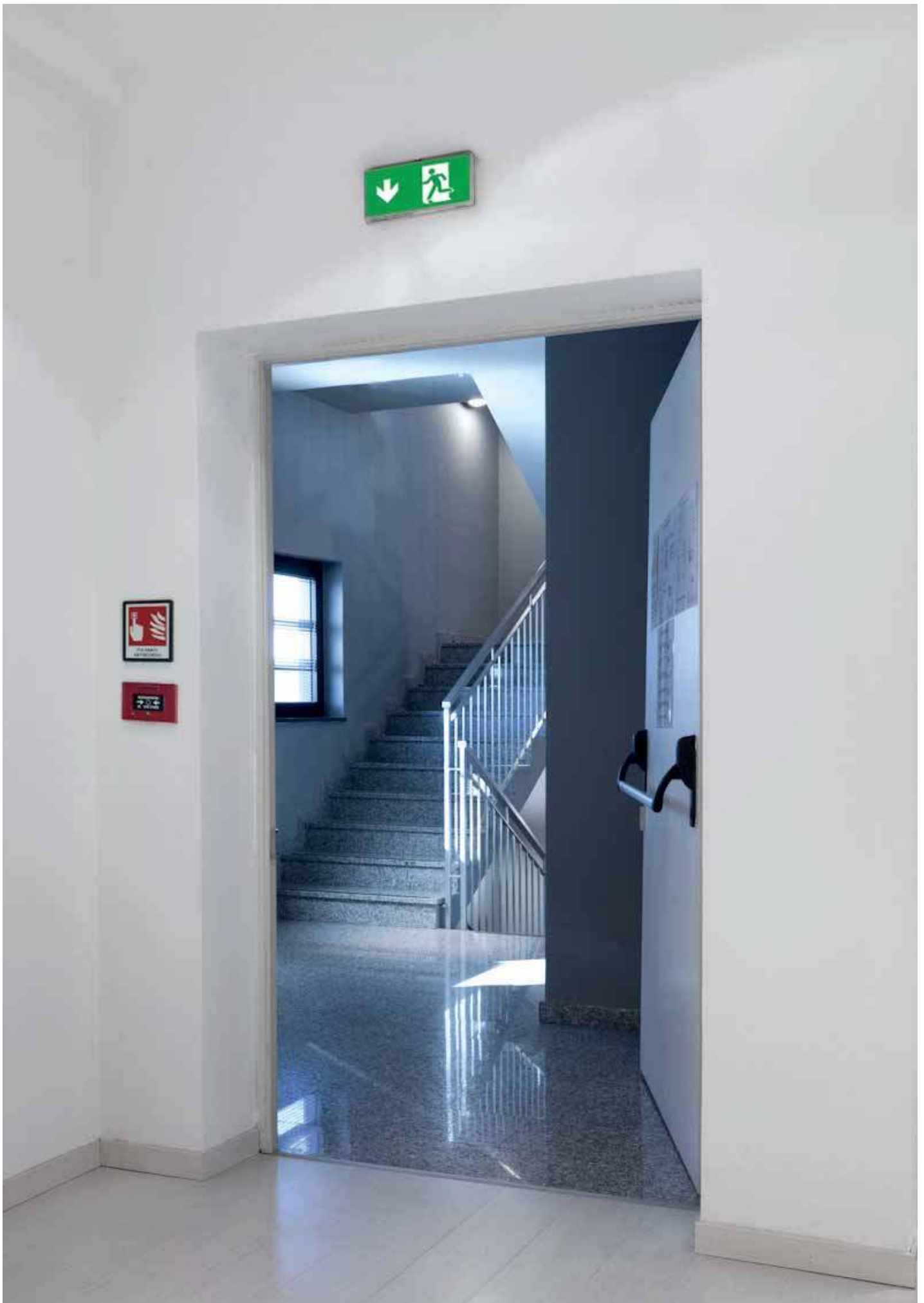

# Accessori non inclusi - Not included accessoires

Codice/Code	Descrizione/Description
R00365	1 Griglia di protezione antivandalo - <i>Anti-vandalism protection grid.</i>
R00338SIG	2 5 segnali di sicurezza (adesivi) - <i>5 safety signs (adhesives).</i>
R00338DOU	3 Kit segnaletica di sicurezza bifacciale (PC 10mm + 5 adesivi) - <i>Kit Double sided diffuser with safety signs (PC 10mm+ 5 adhesives).</i>

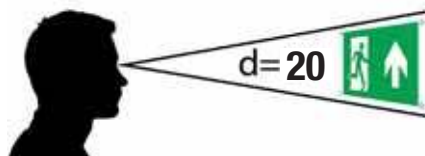
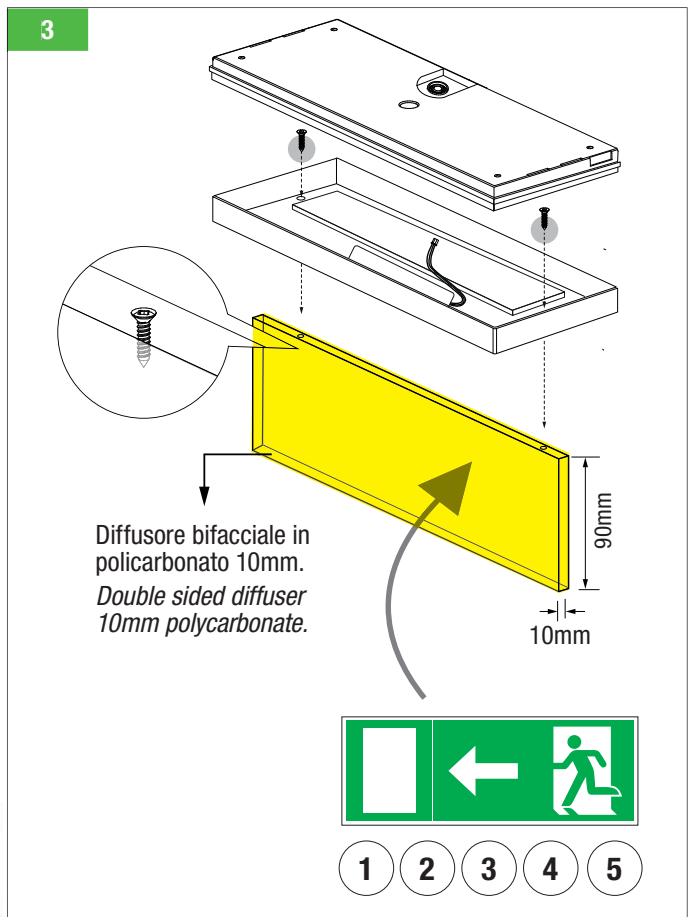
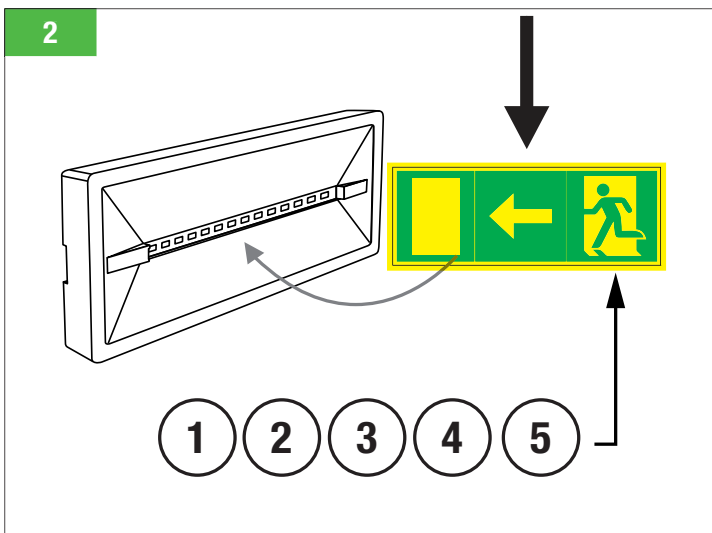
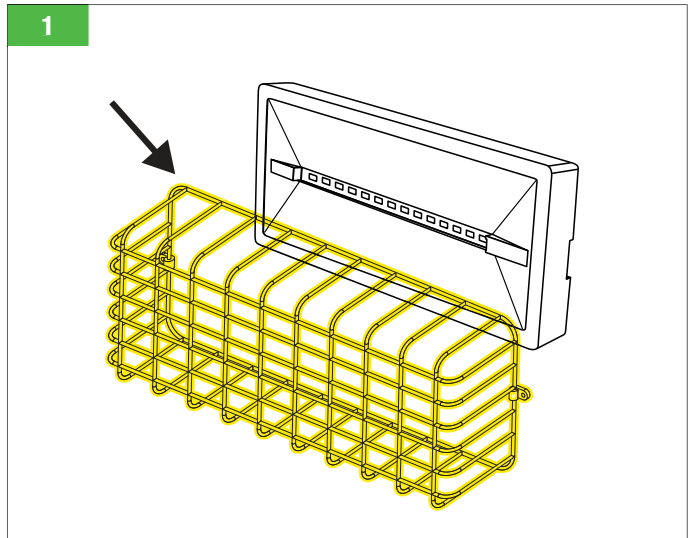

# LED Sirio

<b>Potenza*:</b>	2W (11W*) , 3W (18W*)	<b>Power*:</b>	2W (11W*) , 3W (18W*)
<b>Temperatura colore:</b>	6000K	<b>Kelvin temperature:</b>	6000K
<b>Alimentazione:</b>	220-240V~, 110V~ a richiesta.	<b>Current:</b>	220-240V~, 110V~ on request.
<b>Funzionamento:</b>	SA (Sempre accesa) - SE (Solo Emergenza) Rest-Mode: con dispositivo opzionale (cod. R00325).	<b>Functioning:</b>	M (Maintained) - N/M (Non-Maintained) Rest-Mode: with an optional device (code R00325).
<b>Conforme alle norme:</b>	EN60598-1; EN60598-2-2; EN60598-2-22; EN62471; EN62031; EN61347-1; EN61347-2-13.	<b>According to standard:</b>	EN60598-1; EN60598-2-2; EN60598-2-22; EN62471; EN62031; EN61347-1; EN61347-2-13.
<b>Grado di protezione:</b>	IP42 (IP65 con accessorio cod.R00310)	<b>IP Degree:</b>	IP42 (IP65 with accessory cod.R00310)
<b>Inibizione:</b>	vedi tabella	<b>Inibition:</b>	See table
<b>Autonomia:</b>	1h, 2h, 3h	<b>Autonomy:</b>	1h, 2h, 3h
<b>Temperatura ambiente:</b>	-20 °C ÷ +40 °C.	<b>Operating ambient temperature:</b>	-20 °C ÷ +40 °C.
<b>Installazioni:</b>	Soffitto, parete, parete a bandiera 90°, binario trifase, sospensione con tiges e cavi, incasso controsoffitto.	<b>Installation:</b>	Ceiling, wall, 90° flag wall, three-phase track, suspension with tiges and cables, recessed false ceiling.
<b>Alimentatore:</b>	driver elettronico a corrente costante.	<b>Driver:</b>	Electronic constant current driver.
<b>Corpo:</b>	Polycarbonato bianco RAL 9003.	<b>Body:</b>	White polycarbonate RAL 9003.
<b>Sorgente:</b>	Modulo LED	<b>Light source:</b>	LED module
<b>Ottica:</b>	Simmetrica	<b>Optic:</b>	Simmetrical
<b>Schermo:</b>	Polycarbonato trasparente	<b>Shield:</b>	Transparent polycarbonate

\* Potenza indicativa per il confronto con tubo fluorescente (a parità di lumen prodotti).

\* Power indicative by comparison with fluorescent tube (at the same produced lumen)

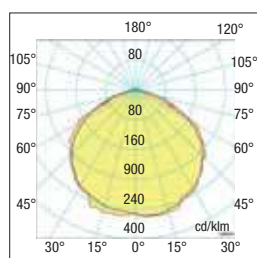
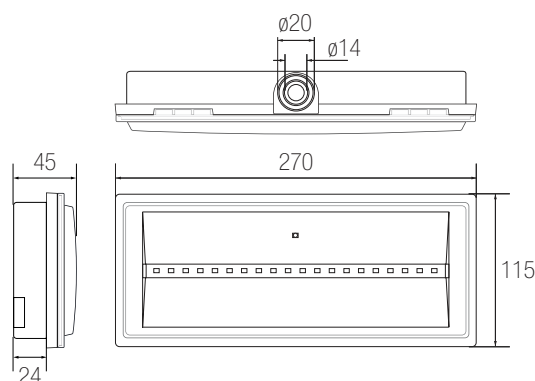

**Dati fotometrici**  
**Photometric data**

## Accessori non inclusi - *Not included accessoires*

da ordinare separatamente - *to be ordered separately*

Codice/Code	Descrizione/Description	Pag.
R00301	1 Kit Binario trifase - <i>Threephase track kit</i>	502
R00310	2 Kit IP 65	502
R00315	3 Kit controsoffitto molle e staffa - <i>Kit recessed springs and brackets</i>	502
8450S	4 Kit sospensione per bandiera - <i>Suspension kit for double sided diffuser.</i>	502
R00330	5 Scatola da incasso - <i>Built-in mounting box</i>	502
R00331	6 Cornice per incasso - <i>Flush mounting frame.</i>	502
R00365	7 Griglia di protezione antivandalo - <i>Anti-vandalism protection grid.</i>	502
R00325	8 Comando centralizzato per l'inibizione dell'emergenza - <i>Controller Rest-mode.</i>	502
R00320	9 5 segnali di sicurezza (adesivi) - <i>5 safety signs (adhesives).</i>	503
R00335	10 Kit segnaletica di sicurezza bifacciale (PMMA 10mm + 5 adesivi) - <i>Kit Double sided diffuser with safety signs (PMMA 10mm+ 5 adhesives).</i>	503
R00335SXDX	11 Segnaletica di sicurezza bifacciale indicazione sinistra/destra - <i>double sided indicator left/right safety signs</i>	503
R00335DIR	11 Segnaletica di sicurezza bifacciale indicazione diritto - <i>double sided indicator straight safety signs</i>	503
R00335EX	11 Segnaletica di sicurezza bifacciale indicazione (exit) - <i>double sided safety signs indicator (exit).</i>	503

Fissaggio a soffitto  
Ceiling fixing



Fissaggio a parete  
Wall fixing



8 Rest-mode

vedi pag. see page  
**504**

SOLO PER VERSIONI AUTOTEST  
ONLY FOR AUTOTEST VERSION

Installazione su binario trifase  
three-phase track Installation



Installazione a sospensione  
Suspension installation



Installazione ad incasso con cornice  
Recessed installation with frame



220-240 Vac    110 a richiesta on demand Vac    50/60 Hz    IP42 / IP65    IK08    M/M    850°    +40°C -20°C    CE

LED Sirio ECO														
Descrizione Description	Potenza* Power W	Versione Version	Autonomia** Autonomy h.	Inibizione Inhibition switch	Batteria Battery Ni-Cd		Ricarica Recharge h.	Flusso medio Average flow		n° LED	Assorb. max Absorpt. max		Pcs	Codice Code
					Volt	Ah		SE lm	SA lm		SE W	SA W		
SIRIO IP42 11 SE 1H V X	2W (11W*)	SE	1 (3)	NO	2,4	0,8	12	120	-	5	1,2	-	12	1956LSREL
SIRIO IP42 11 SA-SE 1H V X	2W (11W*)	SE SA	1 (3)	NO	2,4	0,8	12	100	50	9	1,2	1,7	12	1956LSAREL

LED Sirio														
Descrizione Description	Potenza* Power W	Versione Version	Autonomia** Autonomy h.	Inibizione Inhibition switch	Batteria Battery		Ricarica Recharge h.	Flusso medio Average flow		n° LED	Assorb. max Absorpt. max		Pcs	Codice Code
					Volt	Ah		SE lm	SA lm		SE W	SA W		
SIRIO IP42 11 SE 1H V I	2W (11W*)	SE	1 (3)	SI	3,6	0,8	12	150	-	20	2,7	-	12	1956L20REL
SIRIO IP42 11 SE 3H V I	2W (11W*)	SE	3 (9)	SI	3,6	1,6	24	150	-	20	2,9	-	12	1992L20REL
SIRIO IP42 18 SE 1H V I	3W (18W*)	SE	1 (3)	SI	3,2	1,5	12	400	-	20	3,5	-	12	2046LREL

LED Sirio AUTOTEST														
Descrizione Description	Potenza* Power W	Versione Version	Autonomia** Autonomy h.	Inibizione Inhibition switch + rest mode	Batteria Battery Ni-Cd		Ricarica Recharge h.	Flusso medio Average flow		n° LED	Assorb. max Absorpt. max		Pcs	Codice Code
					Volt	Ah		SE lm	SA lm		SE W	SA W		
SIRIO IP42 11 SE 1H AT C	2W (11W*)	SE	1 (3)	SI	3,6	1,6	12	160	-	20	1,6	-	12	1956L20AREL
Ⓝ SIRIO IP42 11 SA-SE 3H AT C	2W (11W*)	SE SA	1 (3)	SI	3,6	1,6	12	160	160	20	1,6	3,5	12	1992L20ASAREL

Ⓝ NEMKO - Certificato di sicurezza e compatibilità elettromagnetica - Safety and electromagnetic compatibility certificate.  
 \*Potenza indicativa per il confronto con tubo fluorescente (a parità di lumen prodotti) - Power indicative by comparison with fluorescent tube (at the same produced lumen).  
 \*\*Rimuovendo il Jumper interno si triplica l'autonomia e si riduce ad 1/3 il flusso luminoso - Removing the internal Jumper triples autonomy and reduces the light flow to 1/3

Indicatori LED Autodiagnosi - LED indicator Autotest

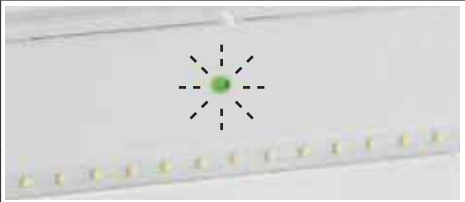
	☀ Fisso - Fixed light	☀ Lampeggiante - Flashed light	
Verde - Green	Batteria carica Battery charged	Batteria in carica Battery in charge	
Rosso - Red	Lampada guasta Lamp fail	Batteria guasta e / o e autonomia insufficiente Battery fail and/or insufficient autonomy	
Arancio - Orange	Lampada inibita in assenza di rete Lamp inhibited in no mains condition	Inibizione test funzionale e di autonomia Functional and autonomy tests inhibited	

# LED Venere

<b>Potenza*:</b>	3W (24W*) 5W (36W*)
<b>Temperatura colore:</b>	6000K
<b>Alimentazione:</b>	220-240V~, 110V~ a richiesta.
<b>Funzionamento:</b>	SA (Sempre accesa) - SE (Solo Emergenza) Rest-Mode: con dispositivo opzionale (cod. R00325).
<b>Conforme alle norme:</b>	EN60598-1; EN60598-2-2; EN60598-2-22; EN62471; EN62031; EN61347-1; EN61347-2-13.
<b>Grado di protezione:</b>	IP42 (IP65 con accessorio cod.R00310)
<b>Inibizione:</b>	vedi tabella
<b>Autonomia:</b>	1h, 2h, 3h
<b>Temperatura ambiente:</b>	-20 °C ÷ +40 °C.
<b>Installazioni:</b>	Soffitto, parete, parete a bandiera 90°, binario trifase, sospensione con tiges e cavi, incasso controsoffitto.
<b>Alimentatore:</b>	driver elettronico a corrente costante.
<b>Corpo:</b>	Polycarbonato bianco RAL 9003.
<b>Sorgente:</b>	Modulo LED
<b>Ottica:</b>	Simmetrica
<b>Schermo:</b>	Polycarbonato trasparente

<b>Power*:</b>	3W (24W*) 5W (36W*)
<b>Kelvin temperature:</b>	6000K
<b>Current:</b>	220-240V~, 110V~ on request.
<b>Functioning:</b>	M (Maintained) - N/M (Non-Maintained) Rest-Mode: with an optional device (code R00325).
<b>According to standard:</b>	EN60598-1; EN60598-2-2; EN60598-2-22; EN62471; EN62031; EN61347-1; EN61347-2-13.
<b>IP Degree:</b>	IP42 (IP65 with accessory cod.R00310)
<b>Inibition:</b>	See table
<b>Autonomy:</b>	1h, 2h, 3h
<b>Operating ambient temperature:</b>	-20 °C ÷ +40 °C.
<b>Installation:</b>	Ceiling, wall, 90° flag wall, three-phase track, suspension with tiges and cables, recessed false ceiling.
<b>Driver:</b>	Electronic constant current driver.
<b>Body:</b>	White polycarbonate RAL 9003.
<b>Light source:</b>	LED module
<b>Optic:</b>	Simmetrical
<b>Shield:</b>	Transparent polycarbonate

\* Potenza indicativa per il confronto con tubo fluorescente (a parità di lumen prodotti).

\* Power indicative by comparison with fluorescent tube (at the same produced lumen)

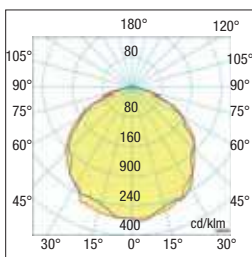
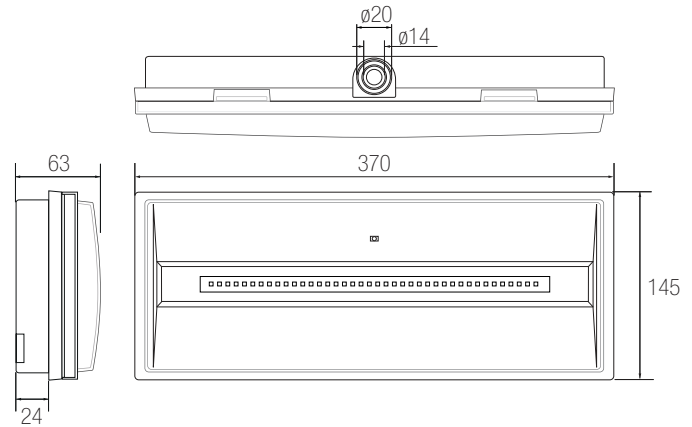
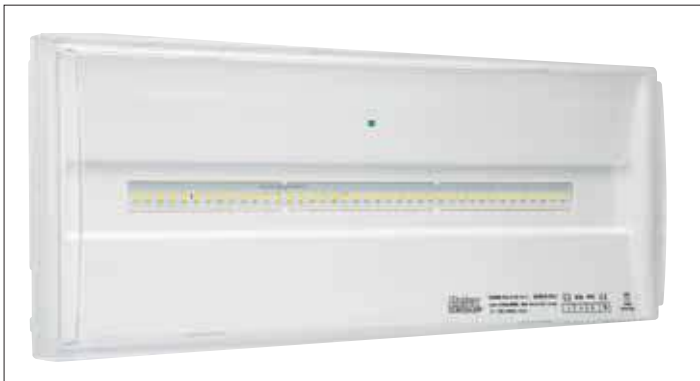

**Dati fotometrici**  
**Photometric data**

## Accessori non inclusi - *Not included accessoires*

da ordinare separatamente - *to be ordered separately*

Codice/Code	Descrizione/Description	Pag.
R00301	1 Kit Binario trifase - <i>Threephase track kit</i>	502
R00312	2 Kit IP 65	502
R00315	3 Kit controsoffitto molle e staffa - <i>Kit recessed springs and brackets</i>	502
8450S	4 Kit sospensione per bandiera ( <b>ordinare 2 pezzi</b> ) - <i>Suspension kit for double sided diffuser (order 2 pieces)</i> .	502
R00334	5 Scatola da incasso - <i>Built-in mounting box</i>	502
R00332	6 Cornice per incasso - <i>Flush mounting frame</i> .	502
R00365	7 Griglia di protezione antivandalo - <i>Anti-vandalism protection grid</i> .	502
R00325	8 Comando centralizzato per l'inibizione dell'emergenza - <i>Controller Rest-mode</i> .	502
R00322	9 5 segnali di sicurezza (adesivi) - <i>5 safety signs (adhesives)</i> .	503
R00337	10 Kit segnaletica di sicurezza bifacciale (PMMA 10mm + 5 adesivi) - <i>Kit Double sided diffuser with safety signs (PMMA 10mm+ 5 adhesives)</i> .	503
R00337SXD	11 Segnaletica di sicurezza bifacciale indicazione sinistra/destra - <i>double sided indicator left/right safety signs</i>	503
R00337DIR	11 Segnaletica di sicurezza bifacciale indicazione diritto - <i>double sided indicator straight safety signs</i>	503
R00337EX	11 Segnaletica di sicurezza bifacciale indicazione (exit) - <i>double sided safety signs indicator (exit)</i> .	503

Fissaggio a soffitto  
Ceiling fixing



Fissaggio a parete  
Wall fixing



8 Rest-mode

vedi pag. see page  
**504**

**SOLO PER VERSIONI AUTOTEST ONLY FOR AUTOTEST VERSION**

Installazione su binario trifase  
three-phase track Installation



Installazione a sospensione  
Suspension installation



Installazione ad incasso con cornice  
Recessed installation with frame



220-240 Vac    110 Vac a richiesta on demand    50/60 Hz    IP42 / IP65    IK08    M/M    850°    +40 C° -20 C°    CE

**LED Venere**

Descrizione Description	Potenza* Power W	Versione Version	Autonomia** Autonomy h.	Inibizione Inhibition switch	Batteria Battery LiFePO4		Ricarica Recharge h.	Flusso medio Average flow SE lm		n°LED	Assorb. max Absorpt. max SE W		Pcs	Codice Code
					Volt	Ah		SE lm	SA lm		SE W	SA W		
VENERE IP42 24 SE 1H V I 110	3W (24W*)	SE	1 (3)	SI	3,2	1,6	12	320		40	2,9		10	12104L40RE110
VENERE IP42 24 SE 1H V I	3W (24W*)	SE	1 (3)	SI	3,2	1,6	12	320		40	2,9		10	12104L40REL
VENERE IP42 24 SE 1H V I H	3W (24W*)	SE	1	SI	3,2	3,0	12	700		40	3,2		10	12104H40REL
VENERE IP42 24 SE-SA 1H V I H	3W (24W*)	SE   SA	1	SI	3,2	3,0	12	750		40	3,2		10	12104H40REL/SA
VENERE IP42 36 SE 1H V I H	5W (36W*)	SE	1 (2)	SI	3,2	6,0	12	1000		40	3,2		10	12104SH40REL

110V

**LED Venere AUTOTEST**

Descrizione Description	Potenza* Power W	Versione Version	Autonomia** Autonomy h.	Inibizione Inhibition switch + rest mode	Batteria Battery Ni-Cd		Ricarica Recharge h.	Flusso medio Average flow		n°LED	Assorb. max Absorpt. max		Pcs	Codice Code
					Volt	Ah		SE lm	SA lm		SE W	SA W		
VENERE IP42 24 SE 1H AT C	3W (24W*)	SE	1 (3)	SI	3,6	1,6	12	320	-	40	1,6	-	10	12104L40AREL
VENERE IP42 24 SA-SE 1H AT C	3W (24W*)	SE   SA	1 (3)	SI	3,6	1,6	12	320	320	40	1,6	6,0	10	12104L40ASA
VENERE IP42 24 SE 1H AT C	3W (24W*)	SE	1	SI	3,6	4	24	700		36	1,6		10	12104H40AREL

Ⓝ **NEMKO** - Certificato di sicurezza e compatibilità elettromagnetica - *Safety and electromagnetic compatibility certificate.*  
 \*Potenza indicativa per il confronto con tubo fluorescente (a parità di lumen prodotti) - *Power indicative by comparison with fluorescent tube (at the same produced lumen).*  
 \*\*Rimuovendo il Jumper interno si triplica l'autonomia e si riduce ad 1/3 il flusso luminoso - *Removing the internal Jumper triples autonomy and reduces the light flow to 1/3*

Indicatori LED Autodiagnosi - *LED indicator Autotest*

	☀ Fisso - <i>Fixed light</i>	☀ Lampeggiante - <i>Flashed light</i>	
Verde - <i>Green</i>	Batteria carica <i>Battery charged</i>	Batteria in carica <i>Battery in charge</i>	
Rosso - <i>Red</i>	Lampada guasta <i>Lamp fail</i>	Batteria guasta e / o e autonomia insufficiente <i>Battery fail and/or insufficient autonomy</i>	
Arancio - <i>Orange</i>	Lampada inibita in assenza di rete <i>Lamp inhibited in no mains condition</i>	Inibizione test funzionale e di autonomia <i>Functional and autonomy tests inhibited</i>	

LED Safety Lighting

# Accessori non inclusi LED Sirio- LED Venere

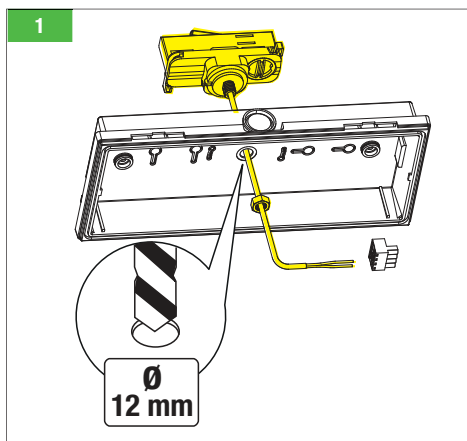

Rif.	Codice Code	Descrizione Description
SIRIO	R00301	Kit Binario trifase
VENERE		Three phase track kit

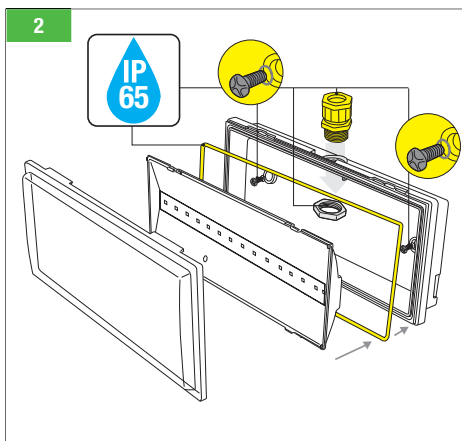

Rif.	Codice Code	Descrizione Description
SIRIO	R00310	Kit IP 65
VENERE	R00312	Kit IP 65

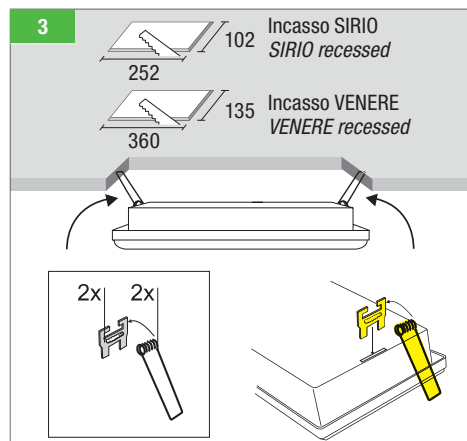

Rif.	Codice Code	Descrizione Description
SIRIO	R00315	Kit controsoffitto molle e staffa
VENERE		Kit recessed springs and brackets

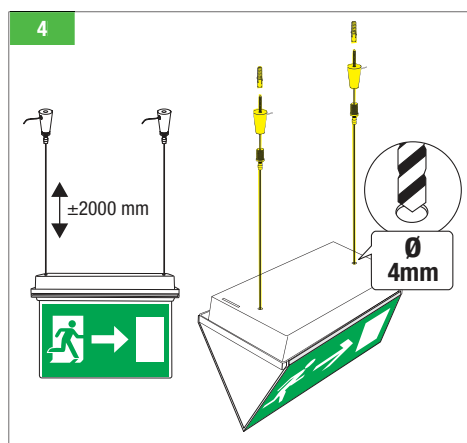

Rif.	Codice Code	Descrizione Description
SIRIO	8450S	Kit sospensione per bandiera
VENERE	(2X) 8450S	Suspension kit for double sided diffuser.

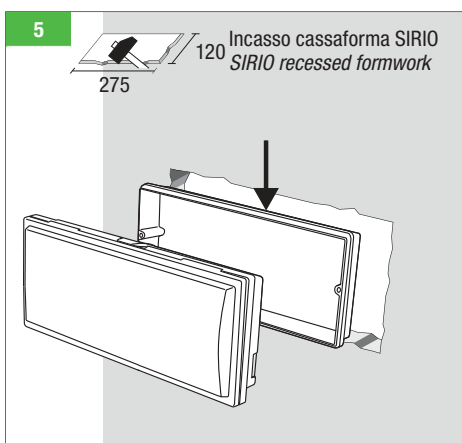

Rif.	Codice Code	Descrizione Description
SIRIO	R00330	Scatola da incasso Built-in mounting box

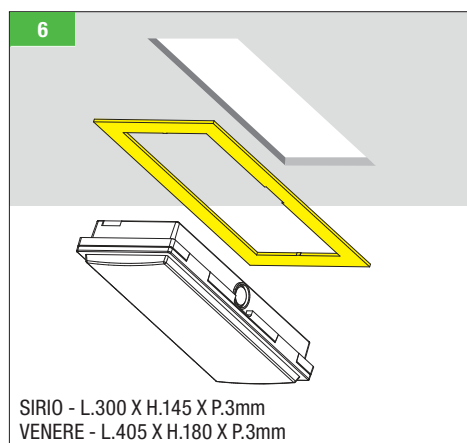

Rif.	Codice Code	Descrizione Description
SIRIO	R00331	Cornice per incasso Flush mounting frame
VENERE	R00332	Cornice per incasso Flush mounting frame

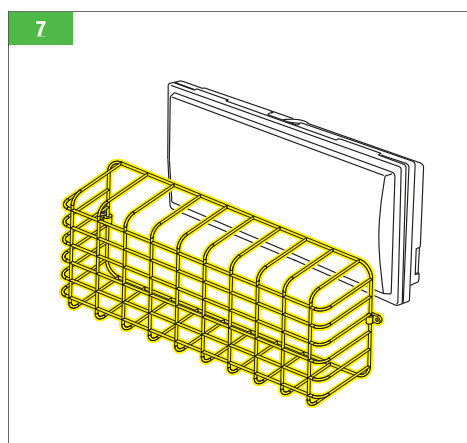

Rif.	Codice Code	Descrizione Description
SIRIO	R00365	Griglia di protezione anti-vandalo
VENERE		Anti-vandalism protection grid



Rif.	Codice Code	Descrizione Description
SIRIO	R00325	Comando centralizzato per l'inibizione dell'emergenza
VENERE		Centralized command for emergency inhibition (Controller Rest-mode)

LED Safety Lighting

# LED Sirio- LED Venere not included accessoires

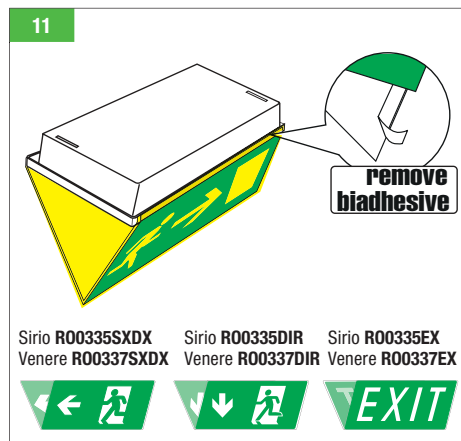
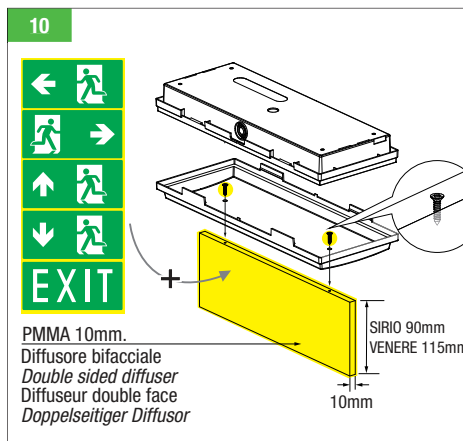
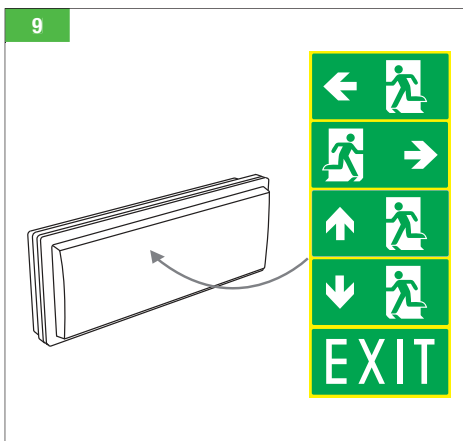

Rif.	Codice Code	Descrizione Description	DV* (m)
SIRIO	R00320	5 segnali di sicurezza adesivi	18
VENERE	R00322	5 safety signs adhesives	22

Rif.	Codice Code	Descrizione Description	DV* (m)
SIRIO	R00335	Kit Supporto PMMA e 10 segnali (adesivi)	9
VENERE	R00337	Kit PMMA support and 10 signs adhesives	11

Rif.	Codice Code	Descrizione Description	DV* (m)
SIRIO	R00335SXDX	SX - DX	32
	R00335DIR	diritto- straight	
	R00335EX	exit	
VENERE	R00337SXDX	SX - DX	40
	R00337DIR	diritto- straight	
	R00337EX	exit	

\*DV=Distanza di visibilità in metri - Visibility distance in meter

\*DV=Distanza di visibilità in metri - Visibility distance in meter

\*DV=Distanza di visibilità in metri - Visibility distance in meter



Segnali di sicurezza in policarbonato opalino 0,5mm. con adesivo sul retro per facilitarne l'installazione  
Opal polycarbonate safety signs 0,5mm. with adhesive on the back to facilitate installation

vedì See **9**    vedì See **10**

Adesivo segnale SX  
Adhesive sign SX

Adesivo segnale DX  
Adhesive sign DX

Adesivo segnale BASSO  
Adhesive sign BOTTOM

Adesivo segnale EXIT  
Adhesive sign EXIT

Adesivo segnale NEUTRO  
Adhesive sign NEUTRAL

Istruzioni di montaggio adesivo segnale di sicurezza  
Assembly instructions adhesive safety sign

vedì See **11**

Segnali di sicurezza in policarbonato opalino 1mm.  
Polycarbonate safety signs 1mm.

Segnale bifacciale sinistra/destra  
Double sided left/right safety signs

Segnale bifacciale diritto  
Double sided straight safety signs

Segnale bifacciale EXIT  
Double sided EXIT safety signs

LED Sirio batteria di ricambio - Spare battery			
batteria di ricambio spare battery	per Codici for Code		
00PB1400	1943LREL	1956LSREL	1956LSAREL
00PB1600	1956L2SAREL		
00PB1000	1956L20REL	1956L20AREL	1956L20ASAREL
00PB1100	1992L20REL	1956L20AREL	1992L20ASAREL

LED Venere batteria di ricambio-Spare battery			
batteria di ricambio spare battery	per Codici for Code		
00PB1100	12104L40REL		
00PB100JST	12104/3L40ASA	12104H40REL	12104L40ASAH
00PB0400	12104L40REL		
00PB0500	12104/3L40REL		



# AT Autotest

Comando centralizzato per l' inibizione dell'emergenza.  
*Centralised control to inhibit the emergency light.*

## ● CARATTERISTICHE TECNICHE

Accessorio a richiesta per inibire le lampade (solo per versioni AUTOTEST) in fase di manutenzione e verifica del corretto funzionamento dell'impianto, inoltre garantisce le operazioni di controllo che devono essere effettuate dal Responsabile della sicurezza secondo il D.Lgs 81/08 del testo unico sulla sicurezza nei luoghi di lavoro.

Il test di autonomia comprende il controllo di tutte le funzioni della lampada in un arco di tempo pari all'autonomia richiesta dalle singole normative ed è effettuato ogni 26 settimane, inoltre è previsto un test di funzionamento ogni 28 giorni, relativo a lampada, batteria e circuito.

Il risultato dei test è visualizzato da led multicolore posizionato sugli apparecchi. Questo garantisce sempre il perfetto controllo del funzionamento e consente un risparmio economico sui costi del personale altrimenti addetto alla manutenzione.

**RICARICA A CONTROLLO ELETTRONICO PER RISPARMIARE ENERGIA E RADDOPPIARE LA VITA DELLA BATTERIA**

Per ovviare allo spreco di energia causato dalla continua ricarica degli apparecchi di emergenza, Relco ha realizzato un sistema di ricarica che dopo 12 ore (ciclo completo) passa automaticamente ad una fase di autonomia per mantenere la carica contenendo l'assorbimento a meno di un Watt.

Questo sistema riduce lo spreco di energia, limita gli accumuli termici e lo stress della batteria che avrà una durata utile di circa il doppio di quanto si otterrebbe con un circuito convenzionale.

## ● TECHNICAL FEATURES

Optional accessory to inhibit lamps (only for AUTOTEST version) during maintenance and when inspecting correct operation of the system. It also guarantees the control operations which must be carried out by the Safety manager according to Leg. Decree 81/08 of the consolidated act on safety at the work place.

The autonomy test includes controlling all functions of the light within a time span equal to the autonomy required by the individual standards and is carried out every 26 weeks. An operating tests of the light, battery and circuit is also envisioned every 28 days.

The result of the test is displayed by the multi-colour LED installed on the appliances. This always ensures perfect control of operation and saves on expenses which would otherwise be required for maintenance personnel.

**ELECTRONICALLY CONTROLLED RECHARGE TO SAVE ENERGY AND TO DOUBLE THE LIFE TIME OF THE BATTERY**

To address the problem of wasting energy due to continually recharging the emergency devices, Relco has devised a recharge system which after 12 hours (complete cycle) automatically switches to the autonomy phase to hold the charge while reducing absorption to less than one Watt.

This system reduces the waste of energy, limits thermal storage and stress on the battery, approximately doubling its service life respect to that of a conventional circuit.

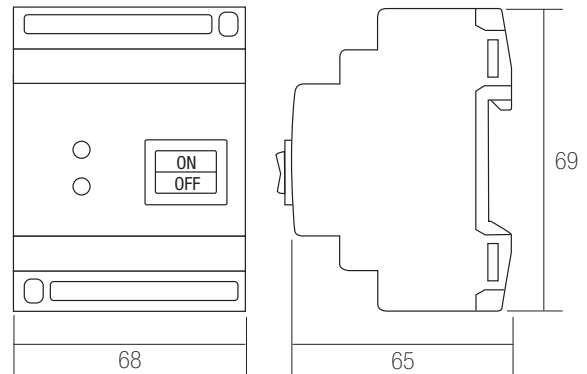

## Controller REST-MODE

Descrizione Description	Dispositivi gestibili Manageable devices	Batteria Battery	Installazione Installation	Peso weight	Imballo Pcs	Code Code
KRM SV - 4moduli DIN	100	NiMH 3,6V 0,3Ah	Guida DIN 3,5X7,5	230 g.	10	RO0325

## Indicatori LED - LED indicator

Verde - Green	Indica la presenza di rete Showing the network presence
Rosso - Red	Indica lo stato della lampada se inibita Showing the state of the lamp if inhibited

Apparecchio autonomo d'emergenza  
Autonomous emergency device

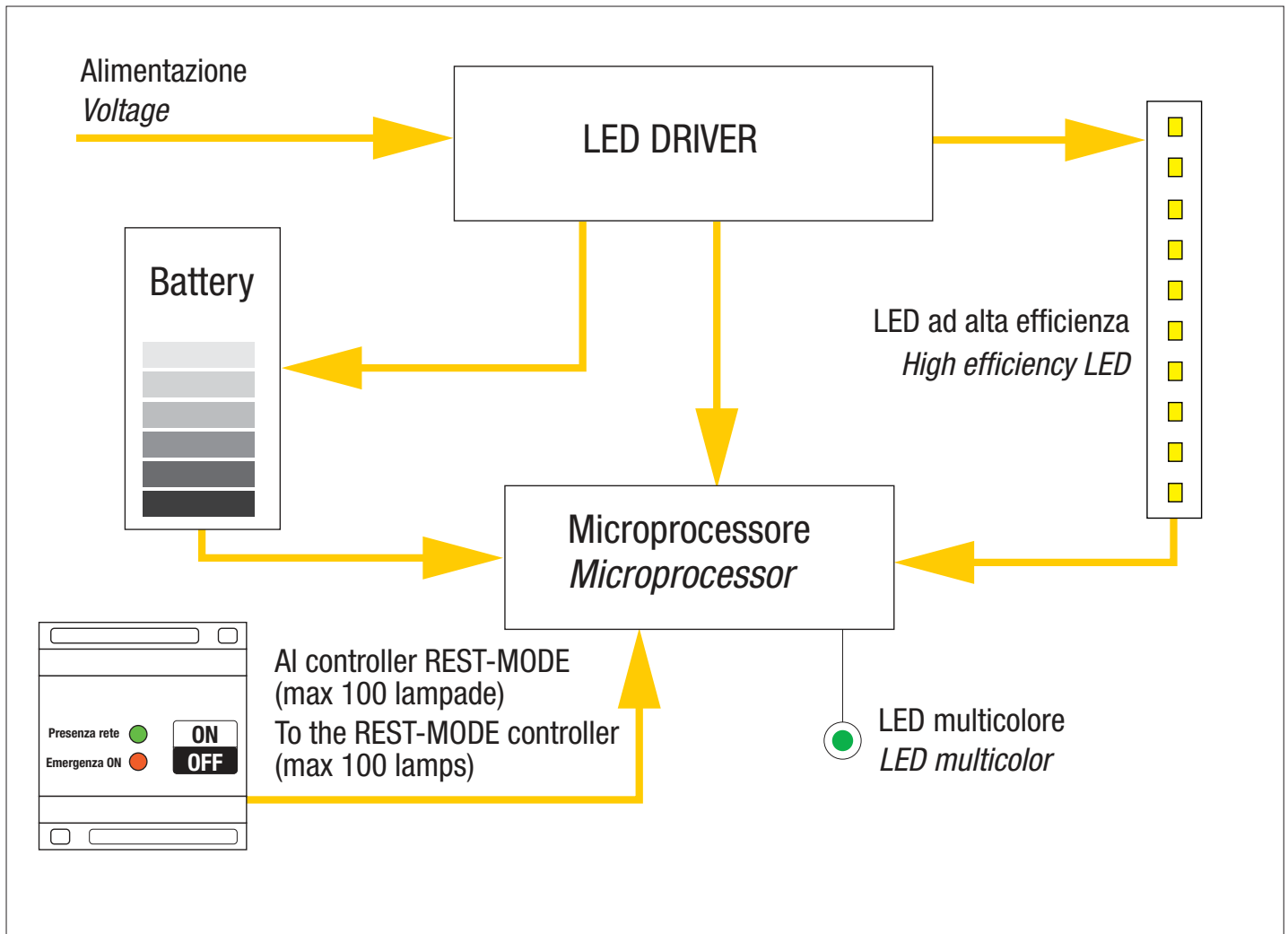

Simboli e omologazioni  
Symbols and approval

<b>W</b>	Potenza <i>Power</i>
<b>Lm</b>	Lumen
<b>Lm/h</b>	Lumen/Ora <i>Lumen/Hours</i>
<b>Battery</b>	Tipo di batteria utilizzata <i>Type of battery used</i>
<b>pcs</b>	Quantità minima ordinabile <i>Minimum quantity to be ordered</i>
<b>IP..</b>	Grado di protezione IP <i>IP protection degree</i>
<b>IK..</b>	Grado di protezione IK <i>IK protection degree</i>
	Temperatura ambiente di funzionamento <i>Operating ambient temperature</i>
<b>SE</b>	<b>SE (solo emergenza) o non permanente</b> La lampada si accende solo quando c'è una interruzione dell'energia elettrica che la alimenta.
<b>N/M</b>	<b>N/M (Non-Maintained)</b> The light is switch on only if there is the power supply to the light is disrupted.

<b>SA</b>	<b>SA (sempre accesa) o permanente</b> La lampada rimane costantemente accesa sia in presenza che in assenza di rete. Questo tipo di funzionamento è adatto ad illuminare un pittogramma per segnalare la via di esodo.
<b>M</b>	<b>M (Maintained)</b> The light remains on constantly if the power grid is operational or not. This type of operation is suitable for illuminating a pictogram to indicate the escape route.
	Apparecchio che resiste alla prova del filo incandescente a 850° <i>The device passes the glow wire test at 850°.</i>
	Apparecchio idoneo all'installazione sui mobili. <i>The device passes the glow wire test</i>
	Apparecchio in classe II, senza morsetto o terminale di terra. <i>Class II device without terminal block or earth terminal</i>
	Apparecchio per uso indipendente <i>Independent use driver</i>
	Apparecchio con corpo costruito con materiali riciclabili <i>The body of this device is made of recyclable material</i>
<b>CE</b>	Tutti i prodotti sono costruiti nel rispetto delle Normative Europee <i>All products are manufactured in compliance with European Standards</i>
	Sicurezza + compatibilità elettromagnetica <i>Safety + electromagnetic compatibility</i>



# LED SPOT EMER SE 3H AUTO TEST

<b>Potenza*:</b>	3W	<b>Power*:</b>	3W
<b>Alimentazione:</b>	220-240V~.	<b>Current:</b>	220-240V~.
<b>Funzionamento:</b>	SE (Solo Emergenza)	<b>Functioning:</b>	N/M (Non-Maintained).
<b>Conforme alle norme:</b>	EN60598-1; EN60598-2-1; EN60598-2-2; EN60598-2-22; EN62493; EN62471; EN62031; EN61347-1; EN61347-2-7; EN61347-2-13; EN55015; EN61000-3-2; EN61000-3-3; EN61547-EN1838	<b>According to standard:</b>	EN60598-1; EN60598-2-1; EN60598-2-2; EN60598-2-22; EN62493; EN62471; EN62031; EN61347-1; EN61347-2-7; EN61347-2-13; EN55015; EN61000-3-2; EN61000-3-3; EN61547-EN1838
<b>Grado di protezione:</b>	IP42	<b>IP Degree:</b>	IP42
<b>Inibizione:</b>	vedi tabella	<b>Inhibition:</b>	See table
<b>Temperatura ambiente:</b>	0-35°C	<b>Operating ambient temperature:</b>	0-35°C
<b>Installazioni:</b>	Incasso.	<b>Installation:</b>	Flush mounting.
<b>Corpo:</b>	Policarbonato bianco.	<b>Body:</b>	White polycarbonate.
<b>2 Ottiche:</b>	Simmetrica - Corridoio.	<b>2 Optics:</b>	Symmetric - Corridor
<b>Schermo:</b>	Policarbonato trasparente.	<b>Shield:</b>	Transparent polycarbonate.



Apparecchiatura di sicurezza LED per l'illuminazione di vie di fuga conforme alle norme EN1838.

**LED SPOT EMER** è composto da:

- Faretto con led.
- Alimentatore per ricarica batteria.
- Batteria Life P04 3,2V 1500mAh.
- Due ottiche intercambiabili.

*LED safety equipment for lighting escape routes compliant with EN1838 standards.*

**SPOT EMER LED** is made up of:

- Spotlight with LED.
- Power supply unit to recharge the battery.
- Battery Life P04 3.2V 1500mAh.
- Two interchangeable optics.



Faretto diametro 60mm da incasso in policarbonato bianco completo di inverter per emergenza con autotest e batteria. **LED SPOT EMER** viene fornito con ottica simmetrica già montata e ottica con lente asimmetrica (corridoio). Funzionamento in SE – Non permanente: il faretto (spento normalmente), in caso di blackout si accende per 3 ore.

*Flush mounting spotlight diameter 60mm in white polycarbonate complete with emergency inverter with autotest and battery. SPOT EMER LED is supplied with pre-mounted symmetrical optics and asymmetrical lens optics (corridor). Operation in SE – Not permanent: the spotlight (normally switched off), in the event of a blackout, turns on for 3 hours.*

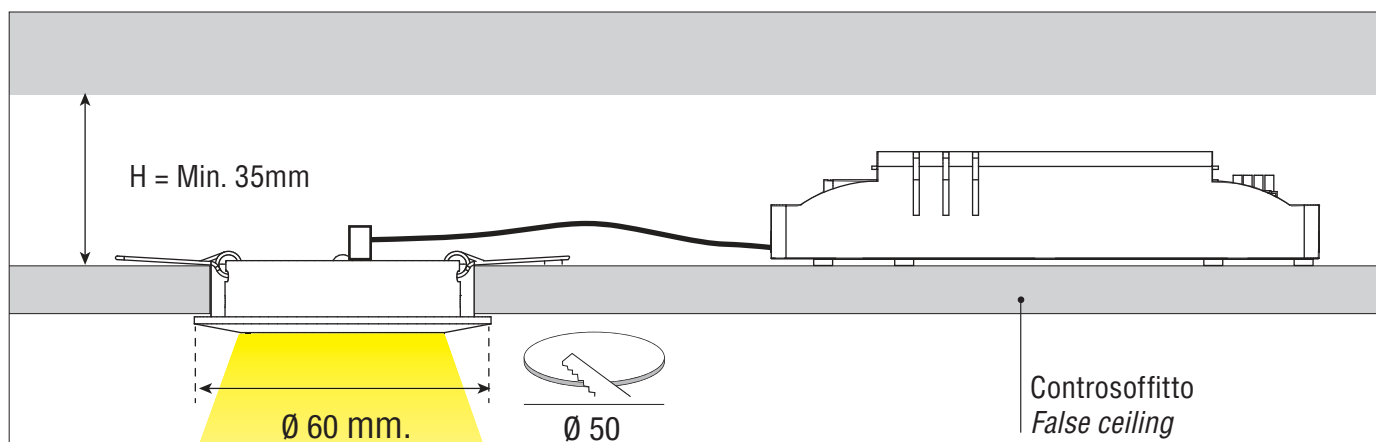



**LED SPOT EMER** con due ottiche a corredo "ottica simmetrica" e "ottica corridoi" che permette l'illuminazione ottimale delle vie di esodo.

*LED SPOT EMER with two optics supplied with "symmetrical optic" and "corridor optic" which allows optimal lighting of escape routes.*

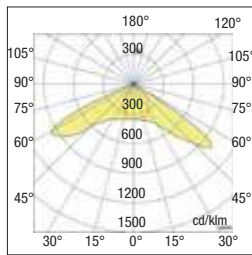
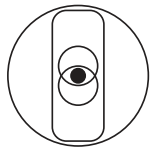

Ottica corridoi  
Corridor optic

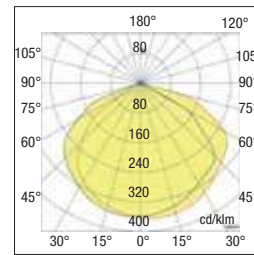
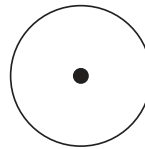

Ottica simmetrica  
Symmetric optic

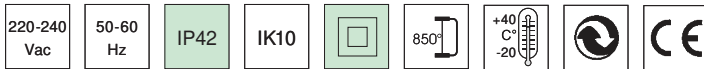
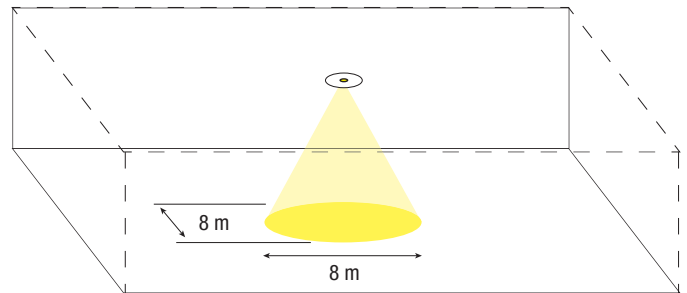
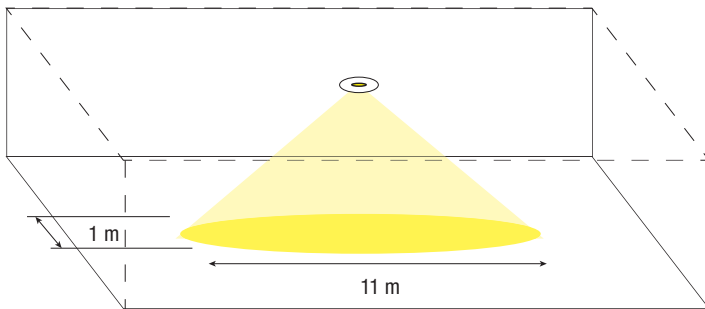

**LED SPOT EMER AUTOTEST**

Descrizione Description	Potenza Power W	Versione Version	Autonomia Autonomy h.	Inibizione Inhibition switch	Batteria Life P04 Battery Life P04 Volt	Ricarica Recharge h.	Flusso medio Average flow SE lm	n° LED	Pcs	Codice Code	
SPOTEMER IP42 SE 3H AT X	3	SE	3	NO	3,2	1500	12	200	1	1	8550REL

**Indicatori LED Autodiagnosi - LED indicator Autotest**

	☀ Fisso - Fixed light	☀ 1 Lampeggio 1 Flashed light	☀ 2 Lampeggi 2 Flashed light	☀ 3 Lampeggi 3 Flashed light	LED
Verde - Green	Condizione normale / Batteria carica Normal condition / Battery full	-	-	-	LED (Green)
Rosso - Red		Batteria guasta Faulty battery	Faretto guasto Faulty spotlight	autonomia insufficiente insufficient autonomy	LED (Red)

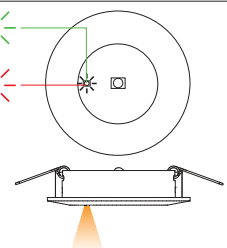

# LED Cuculo - Lampada di emergenza

<b>Potenza*:</b>	1,5W (11W*)
<b>Alimentazione:</b>	220-240V~, 110V~ a richiesta.
<b>Funzionamento:</b>	SA (Sempre accesa) - SE (Solo Emergenza)
<b>Conforme alle norme:</b>	EN60598-1; EN60598-2-2; EN60598-2-22; EN62471; EN62031; EN61347-1; EN61347-2-13.
<b>Grado di protezione:</b>	IP54
<b>Inibizione:</b>	vedi tabella
<b>Autonomia:</b>	1h, 2h
<b>Temperatura ambiente:</b>	-20 °C ÷ +40 °C.
<b>Installazioni:</b>	Soffitto, parete, binario trifase, incasso controsoffitto.
<b>Alimentatore:</b>	driver elettronico a corrente costante.
<b>Corpo:</b>	Polycarbonato bianco RAL 9003.
<b>Sorgente:</b>	Modulo LED
<b>Ottica:</b>	Simmetrica
<b>Schermo:</b>	Polycarbonato opale schermo alluminio antivandalo 503-54

<b>Power*:</b>	1,5W (11W*)
<b>Current:</b>	220-240V~, 110V~ on request.
<b>Functioning:</b>	M (Maintained) - N/M (Non-Maintained) .
<b>According to standard:</b>	EN60598-1; EN60598-2-2; EN60598-2-22; EN62471; EN62031; EN61347-1; EN61347-2-13.
<b>IP Degree:</b>	IP54
<b>Inhibition:</b>	See table
<b>Autonomy:</b>	1h, 2h
<b>Operating ambient temperature:</b>	-20 °C ÷ +40 °C.
<b>Installation:</b>	Ceiling, wall, three-phase track, recessed false ceiling.
<b>Driver:</b>	Electronic constant current driver.
<b>Body:</b>	White polycarbonate RAL 9003.
<b>Light source:</b>	LED module
<b>Optic:</b>	Simmetrical
<b>Shield:</b>	Opal polycarbonate Aluminium anti-vandalism protection shield 503-54

\* Potenza indicativa per il confronto con lampada di emergenza con tubo fluorescente (a parità di lumen prodotti).

\* Power indicative by comparison with emergency lamps with fluorescent tube (at the same produced lumen).

## Accessori non inclusi - *Not included accessoires*

da ordinare separatamente - *to be ordered separately*

Fig.	Descrizione/Description	Codice/Code
1	Scatola sporgente per 503 - <i>Protuding box for 503</i>	503BOX
2	Kit 5 segnali di sicurezza adesivi - <i>Kit 5 safety signs adhesives</i>	R00323

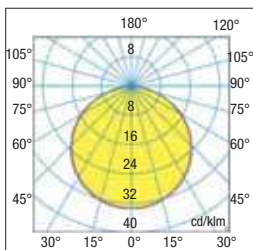
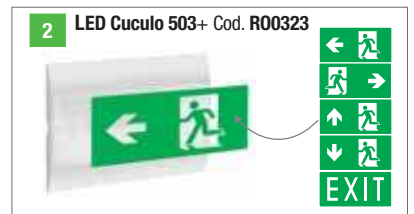
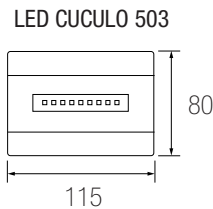
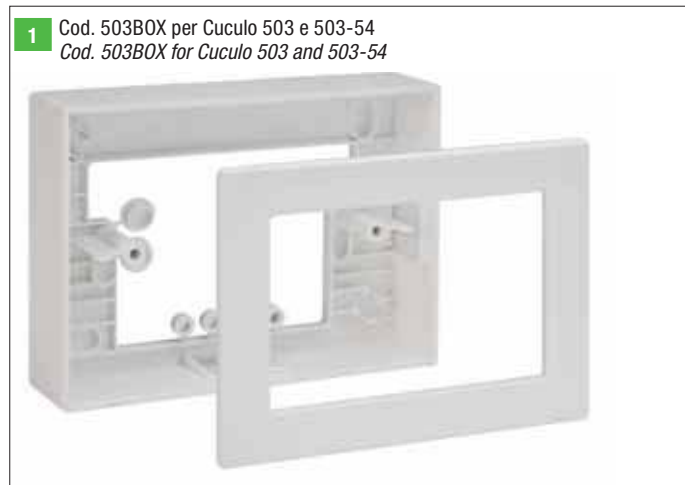

**Dati fotometrici**  
*Photometric data*

## Batteria di ricambio- *Replacement battery*

Fig.	Descrizione/Description	Code
4)	Batteria - Battery 2,4V - 800mAh - SE / SA	00PB1800
5)	Batteria - Battery 2,4V - 1600mAh - HSE	00PB1600



# LED Cuculo - Safety lighting



Lampada di emergenza a LED da incasso ha lo scopo di rendere l'ambiente sicuro e confortevole. L'apparecchio utilizza 3 LED ad alta luminosità e a basso consumo energetico, con elevata durata di funzionamento rispetto alle lampade tradizionali.

Alimentata da un pacco batteria ricaricabile e sostituibile è utilizzata in caso di blackout della rete elettrica, per illuminare il percorso di un Vostro ambiente; è dotata di ingresso per comando remoto di Test e modo di riposo tramite apparecchio opzionale di controllo (S-TE).

Risponde alla normativa italiana CEI 64-8 che ne prevede l'installazione in ogni abitazione e alla norma EN60598-2-22 che definisce le caratteristiche dei prodotti per l'illuminazione di emergenza.

Progettata per l'installazione ad incasso fissa, non estraibile, per scatola 503.

*Recessed LED emergency lamp has the purpose of making the environment safe and comfortable. The luminaire uses 3 high brightness and low energy consumption LEDs, with a long operating life compared to traditional lamps.*

*Powered by a rechargeable and replaceable battery pack, it is used in the event of a blackout in the electricity grid, to illuminate the path of your environment; it is equipped with an input for remote control of Test and rest mode via an optional control device (S-TE). It complies with the Italian CEI 64-8 standard which provides for its installation in every home and with the EN60598-2-22 standard which defines the characteristics of emergency lighting products.*

*Designed for fixed, non-extractable recessed installation for 503 box.*

Incasso  
Recessed

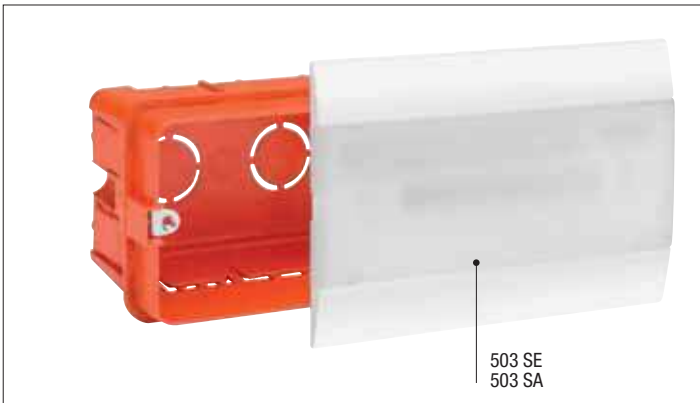

Incasso cartongesso  
Recessed plasterboard

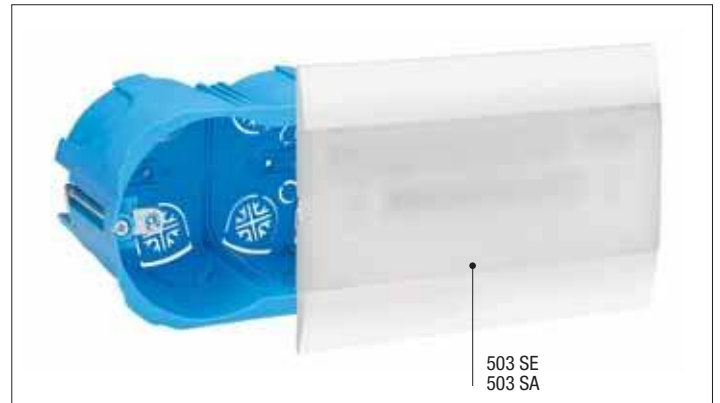

## LED Cuculo 503

Descrizione Description	Potenza* Power W	Versione Version	Autonomia** Autonomy h.	Inibizione Inhibition switch	Batteria Battery Ni-Cd		Ricarica Recharge h.	Flusso medio Average flow		n° LED	Assorb. max W		Pcs	Codice Code
					Volt	Ah		SE lm	SA lm		SE	SA		
CUCULO IP40 11 SE 1H V X	1,5W (11W*)	SE	1(3)	NO	2,4	0,8	12	-	-	5	-	-	10	503SE
CUCULO IP40 11 SA-SE 1H V X	1,5W (11W*)	SA	1(3)	NO	2,4	0,8	12	50	9		2,2		10	503SA

\*Potenza indicativa per il confronto con tubo fluorescente (a parità di lumen prodotti) - Power indicative by comparison with fluorescent tube (at the same produced lumen).

\*\*Rimuovendo il Jumper interno si triplica l'autonomia e si riduce ad 1/3 il flusso luminoso - Removing the internal Jumper triples autonomy and reduces the light flow to 1/3

# LED KEYEMER Emergenza 1 modulo per scatola 503 con attacco Keystone

*Emergency 1 module for box 503 with Keystone connection*

<b>Potenza*:</b>	0,5W
<b>Alimentazione:</b>	100/220-240V~.
<b>Funzionamento:</b>	SA (Sempre accesa) - SE (Solo Emergenza)
<b>Conforme alle norme:</b>	EN60598-1; EN60598-2-2; EN60598-2-22; EN62471; EN62031.
<b>Grado di protezione:</b>	IP20
<b>Inibizione:</b>	vedi tabella
<b>Autonomia:</b>	2h
<b>Temperatura ambiente:</b>	-20°C ÷ +40°C.
<b>Installazioni:</b>	Incasso da scatola 503 con aggancio "KEYSTONE".
<b>Alimentatore:</b>	driver elettronico.
<b>Corpo:</b>	Policarbonato trasparente.
<b>Sorgente:</b>	LED
<b>Ottica:</b>	Simmetrica.
<b>Schermo:</b>	Policarbonato trasparente.

<b>Power*:</b>	0,5W
<b>Current:</b>	100/220-240V~.
<b>Functioning:</b>	M (Maintained) - N/M (Non-Maintained) .
<b>According to standard:</b>	EN60598-1; EN60598-2-2; EN60598-2-22; EN62471; EN62031
<b>IP Degree:</b>	IP20
<b>Inhibition:</b>	See table
<b>Autonomy:</b>	2h
<b>Operating ambient temperature:</b>	-20°C ÷ +40°C.
<b>Installation:</b>	Flush mounting from box 503 with "KEYSTONE" coupling.
<b>Driver:</b>	Electronic driver.
<b>Body:</b>	Transparent polycarbonate.
<b>Light source:</b>	LED
<b>Optic:</b>	Symmetric.
<b>Shield:</b>	Transparent polycarbonate.

**Punti di forza:**

- Compatibile con le principali serie civili mediante adattatori (inclusi).
- Prodotto da incasso con aggancio "KEYSTONE".
- Ingombro da un solo modulo.
- Funzione 2 in 1 SA (Sempre accesa) - SE (Solo Emergenza).
- Consumo <1W.

**Strengths;**

- Compatible with the main civil range using adapters (included).
- Flush mounting product with "KEYSTONE" coupling.
- Single module footprint.
- Function 2 in 1 M (Maintained) - N/M (Non-Maintained).
- Consumption <1W.

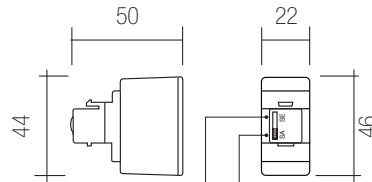

**SA** = Lampada accesa: SA (sempre accesa) in caso di black-out la luce rimane accesa.  
**M** = Lamp on: M (Maintained) in case of black-out, the light remains on.

**SE** = LED verde acceso: SE (solo emergenza) funzione lampada in emergenza, si accende solo in caso di black-out.

**N/M** = LED green on: N/M (Non-Maintained), emergency luminaire function, it turns on only in case of power failure.

Dispositivo di Emergenza a LED da incasso con ingombro a un modulo, ideale per applicazioni residenziali. Installazione in serie civili Biticino o Vimar con funzione in modalità sempre accesa (segnapasso) o solo emergenza.

*LED flush mounting emergency device with one module footprint, ideal for residential applications. Installation in a Biticino or Vimar civil range functioning in always on mode (stair light) or emergency only.*

**Accessori non inclusi - Not included accessoires**

da ordinare separatamente - *to be ordered separately*

Codice/Code	Adattatore Keyemer compatibile con serie civile - Keyemer adapter compatible with civil range
FRT05	1 BTICINO MAGIC AVORIO
FRT35	2 BTICINO LIVING NERO
FRT290	3 BTICINO AXOLUTE BIANCO
FRT200	4 BTICINO AXOLUTE HS DARK
FRT20	5 VIMAR IDEA NERO
FRT310	6 VIMAR ARKE' BIANCO



Adattatore Keyemer inclusi nella confezione  
*Keyemer adapter included in the package*

Compatibile con serie civile - Compatible with civil range

7	BTICINO LIVING LIGHT BIANCO
8	BTICINO LIVING LIGHT INTERNATIONAL NERO
9	BTICINO MATIX BIANCO
10	VIMAR PLANA BIANCO
11	VIMAR ARKE' NERO

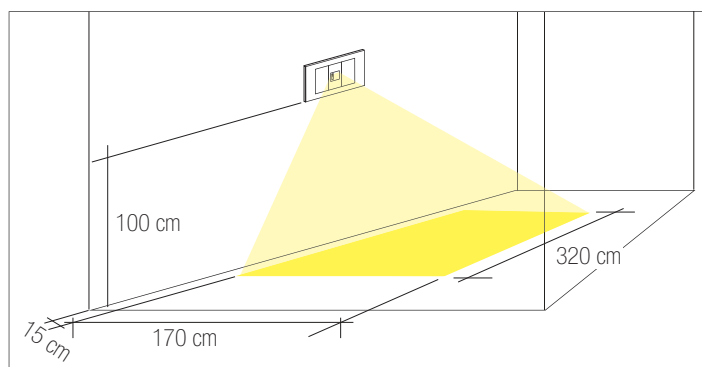
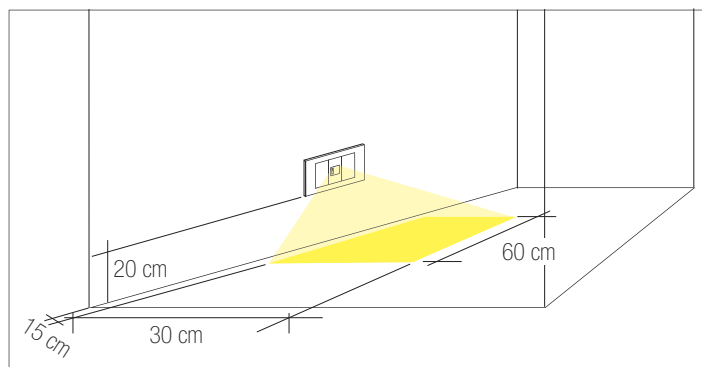

100 Vac	220-240 Vac	50-60 Hz	IP20	IK10		850°	+40 C° -20		CE
---------	-------------	----------	------	------	--	------	---------------	--	----

LED KEYEMER

Descrizione Description	Potenza Power W	Versione Version		Autonomia Autonomy h.	Inibizione Inhibition switch	Batteria Battery Ni-Mh		Ricarica Recharge h.	Flusso medio Average flow		n° LED	Pcs	Codice Code
		SE	SA			Volt	mAh		SE lm	SA lm			
KEYEMER IP20 SA-SE 2H V X	0,5	SE	SA	2	NO	3,6	80	8	30	5	1	1	KEI0001

## Testaletto LED



TRAVE TESTALETTO PER CAMERE DI DEGENZA DI STRUTTURE OSPEDALIERE O CASE DI CURA CON SERVIZI MULTIPLI INTEGRATI SU CANALE E VANO GAS MEDICALI. CONFORME ALLA DIRETTIVA 93/42/CE "DISPOSITIVI MEDICI"

BEDHEAD LIGHT FOR HOSPITAL OR CLINIC APPLICATION WITH INTEGRATED ELECTRICAL DEVICES AND MEDICAL GAS ARRANGEMENT IN COMPLIANCE WITH 93/42/CEE MEDICAL DEVICE DIRECTIVE

### STRUTTURA

Corpo in alluminio estruso ed anodizzato in colore naturale o verniciato in colore RAL a richiesta (spessore medio di 2,5 mm) con spigoli arrotondati. Disponibile anche in ossidazione legno naturale. Testine di chiusura in ABS grigio perla con bordi arrotondati (personalizzabili a richiesta) e fissate con una sola vite per rendere semplice la sola vite per rendere semplice la sostituzione delle lampade o qualsiasi altro intervento di manutenzione straordinaria. Completo di base fissaggio rapido a parete in acciaio zincato. Disponibile in diverse lunghezze a seconda del numero di letti presenti.

### OTTICA

Vano ottico superiore per illuminazione generale indiretta e vano ottico inferiore per luce di lettura e visita. Entrambi i vani montano lastre piane in materiale acrilico trasparente con prismi longitudinali, lisci all'esterno per una facile pulizia e passati con depolarizzante per evitare il deposito di polvere. I prismi sono inoltre orientati in modo da dare la più idonea distribuzione asimmetrica del fascio luminoso verso i piedi dell'ammalato. Riflettore interno in lamiera di acciaio verniciata in bianco.

### CABLAGGIO LED

Moduli LED ad alta efficienza 130 lm/W con IRC>90. Standard di alimentazione 230V-50Hz con driver dedicati. Cablaggio con alimentatori elettronici per lampade fluorescenti T8/T5 a richiesta. All'interno della trave vi sono due diverse canalizzazioni per 230V e per le bassissime tensioni con morsettiere situate in prossimità dell'ingresso cavi. Tutti i cablaggi fanno capo ad una o più morsettiere del tipo presa/spina.

### GAS MEDICALI

Ogni trave è dotata di uno scomparto posteriore, completamente separato dallo scomparto per i conduttori elettrici, che può contenere fino a quattro tubi per gas medicali (non inclusi).

### CONFIGURAZIONI

I servizi elettrici, i sistemi di chiamata e i vari tipi di illuminazione vengono selezionati in base alle esigenze applicative del cliente.

\* Le misure riportate sono puramente indicative. I seguenti articoli sono infatti personalizzabili a seconda delle esigenze tecniche ed estetiche del cliente.

Richiedere un preventivo.

### STRUCTURE

The body is made of steel sheet painted in RAL colour upon request (average thickness of 2,5 mm) with rounded edges. Also available in natural wood oxidation. Closing heads in pearl gray ABS with rounded edges and fixed with a single screw for an easy maintenance. Wall fixing with quick fastening steel plate. Available in different lengths according to the number of the hospital beds.

### OPTICS

Superior optical compartment for indirect lighting and lower optical compartment designed to contain light for reading and patient control. Both compartments have a PMMA diffusor with longitudinal prisms, smooth on the outside for easy cleaning and depolarized to avoid the deposit of dust. The prisms are also oriented in order to give the most appropriate asymmetric beam towards the feet of the patient. The internal reflector is made of white painted steel sheet.

### POWER LED

High efficiency LED modules 130 lm/W CRI>90. Standard 230V/50Hz with dedicated driver. Electronic ballast for fluorescent T8/T5 lamps on request. The profile has two different ducts for 230V and for very low voltages with terminal blocks located near the cable entry. All wirings are part of one or more terminals with fast connectors.

### MEDICAL GAS

Each profile is provided with a rear compartment which is completely separated from the electrical one and contain up to four medical gases tubes.

### LAYOUT

The electrical devices, call systems and various types of lighting are selected according to the customer needs.

\*The data are not binding. These products, in fact, are completely customizable according to the technical and stylist needs.

Required a quotation.

### Testaletto 4501 LED

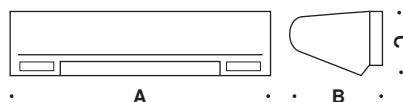

230V 50/60Hz



IK07 IP40

CRI>90



DRIVER INCLUDED

colour	Vac	lm/W	A mm	B mm.	C mm.	CELL
B	230	130	660	185	120	4501.066
B	230	130	960	185	120	4501.096
B	230	130	1300	185	120	4501.130
B	230	130	1600	185	120	4501.160

230V 50/60Hz



IK07

IP40

## Testaletto 4502 LED

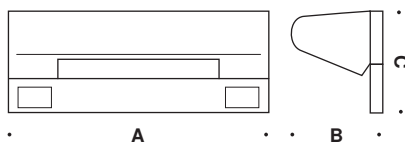

CRI>90



DRIVER INCLUDED

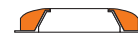

colour	Vac	lm/W	A mm	B mm.	C mm.	CELL
B	230	130	660	185	200	4502.066
B	230	130	960	185	200	4502.096
B	230	130	1300	185	200	4502.130
B	230	130	1600	185	200	4502.160

## Testaletto 4503 LED



CRI>90



DRIVER INCLUDED



colour	Vac	lm/W	A mm	B mm.	C mm.	CELL
B	230	130	1600	242	300	4503.160
B	230	130	1900	242	300	4503.190
B	230	130	3500	242	300	4503.350
B	230	130	5100	242	300	4503.510

## Testaletto 4504 LED

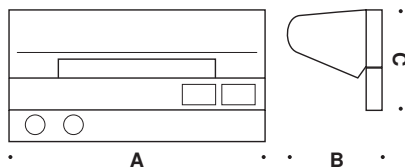

CRI>90



DRIVER INCLUDED

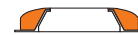

colour	Vac	lm/W	A mm	B mm.	C mm.	CELL
B	230	130	1600	242	300	4504.160
B	230	130	1900	242	300	4504.190
B	230	130	3500	242	300	4504.350
B	230	130	5100	242	300	4504.510

## Clean LED

### STRUTTURA

Corpo in lamiera di acciaio spessore 0,6 mm. Cornice porta schermo con guarnizione stagna in lamiera di acciaio fissata con viti in acciaio INOX. Verniciatura a polveri epossidiche bianco RAL 9003 con trattamento anti-invecchiamento e anti-ingiallimento.

Serie 4109 adatta per l'installazione in controsoffitti con orditura a vista.

Serie 4139 adatta per l'installazione in controsoffitti con orditura nascosta.

Serie 4108 adatta per l'installazione a plafone.

Versioni da incasso equipaggiate con staffe laterali regolabili con asola per eventuale pendinatura. Versioni per controsoffitti speciali disponibili a richiesta.

### OTTICA

Diffusore in policarbonato con microprismi conici a luminanza controllata.

Luminanza media < 3.000 cd/m<sup>2</sup> per angoli >65° radiali, UGR<19.

Ottica con flusso controllato conforme alla normativa UNI EN 12464-1 e al D.Lgs. 81/2008.

Rischio fotobiologico esente (RG0).

### CABLAGGIO

Moduli LED ad alta efficienza dedicati, fattore di potenza >0,95.

Durata utile L85/B10/C0: 90.000 ore (Tp 25°C).

Temperatura colore 4.000°K, IRC (indice di resa cromatica)

>90, MacAdam SDCM 2. Versioni 3.000°K o 5.000°K disponibili a richiesta.

Standard di alimentazione 230V/50Hz con driver dedicato incluso.

### ACCESSORI

Kit Emergenza 1h (cod. 2)

Kit Emergenza 3h (cod. 3)

Kit dimmerabile 1-10V (cod. 4)

Kit dimmerabile DALI (cod. 5)

\* Le misure riportate sono puramente indicative. I seguenti articoli sono infatti personalizzabili a seconda delle esigenze tecniche ed estetiche del cliente.

**Richiedere un preventivo.**

### STRUCTURE

The body is made of steel sheet thickness 0,6mm. Steel diffuser frame with stainless screws. White powder coating RAL 9003. Waterproof gasket. Series 4109 for false ceiling with visible structure.

Series 4139 for false ceiling with hidden structure.

Series 4108 for ceiling installation.

All the recessed version are equipped with adjustable brackets with suspension hole.

Special false ceiling version available on request.

### OPTICS

Diffusor in polycarbonate with conical microprism.

Luminance with <3.000 cd/m<sup>2</sup> radial >65°, UGR<19.

Compliant to the UNI EN 12464-1 and D.Lgs. 81/2008 rules.

Photobiological safety risk exempt (RG0).

### POWER

High efficiency LED modules, power factor >0,95.

Lifetime L85/B10/C0: 90.000 ore (Tp 25°C).

Colour 4.000°K, CRI (color rendering index) >90, initial tolerance MacAdam SDCM 2.

3.000°K or 5.000°K version available on request. Power supply 230V/50Hz. LED driver included.

### ACCESSORIES

Emergency kit 1h (code 2)

Emergency kit 3h (code 3)

Dimmable 1-10V kit (code 4)

Dimmable DALI kit (code 5)

\*The data are not binding. These products, in fact, are completely customizable according to the technical and stylist needs.

**Required a quotation.**

230V 50/60Hz



IK07

IP55

### Clean LED Recessed

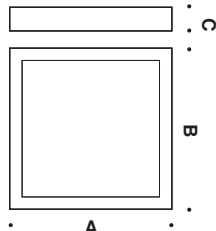

CRI>90

DRIVER INCLUDED



colour	W max	Vac	lm TC=25°C	lm output	K	A mm.	B mm.	C mm.	Kg	CELL
[B]	20	230	3.200	2.620	4000	295	595	90	3	4109.204
[B]	40	230	6.400	5.360	4000	595	595	90	3,50	4109.404
[B]	60	230	9.600	6.604	4000	595	595	90	3,50	4109.604
[B]	50	230	8.000	5.445	4000	295	1.195	90	3,90	4109.504
[B]	100	230	15.000	12.889	4000	595	1.195	90	5,00	4109.104
[B]	40	230	6.400	5.360	4000	598	598	90	3,50	4139.404
[B]	60	230	9.600	6.604	4000	598	598	90	3,50	4139.604
[B]	50	230	8.000	5.445	4000	298	1.198	90	3,90	4139.504
[B]	100	230	15.000	12.889	4000	598	1.198	90	5,00	4139.104

### Clean LED Plafone



colour	W max	Vac	lm TC=25°C	lm output	K	A mm.	B mm.	C mm.	Kg	CELL
[B]	20	230	3.200	2.620	4000	300	600	80	3,50	4108.204
[B]	40	230	6.400	5.360	4000	600	600	80	4	4108.404
[B]	60	230	9.600	6.604	4000	600	600	80	4	4108.604
[B]	50	230	8.000	5.445	4000	300	1.200	80	4,30	4108.504
[B]	100	230	15.000	12.889	4000	600	1.200	80	5,50	4108.104



## Aseptic LED

### STRUTTURA

Corpo in lamiera di acciaio spessore 0,6 mm. Cornice porta schermo con guarnizione stagna in lamiera di acciaio fissata con viti in acciaio INOX. Verniciatura a polveri epossidiche bianco RAL 9003 con trattamento anti-invecchiamento e anti-ingiallimento.

Serie 4111 adatta per l'installazione in controsoffitti con orditura a vista.

Serie 4131 adatta per l'installazione in controsoffitti con orditura nascosta.

Serie 4110 adatta per l'installazione a plafone.

Versioni da incasso equipaggiate con staffe laterali regolabili con asola per eventuale pendinatura. Versioni per controsoffitti speciali disponibili a richiesta.

### OTTICA

Diffusore in policarbonato con microprismi conici a luminanza controllata.

Luminanza media < 3.000 cd/m<sup>2</sup> per angoli >65° radiali, UGR<19.

Ottica con flusso controllato conforme alla normativa UNI EN 12464-1 e al D.Lgs. 81/2008.

Rischio fotobiologico esente (RG0).

### CABLAGGIO

Moduli LED ad alta efficienza dedicati, fattore di potenza >0,95.

Durata utile L85/B10/CO: 90.000 ore (Tp 25°C).

Temperatura colore 4.000°K, IRC (indice di resa cromatica)

>90, MacAdam SDCM 2. Versioni 3.000°K o 5.000°K disponibili a richiesta.

Standard di alimentazione 230V/50Hz con driver dedicato incluso.

### ACCESSORI

Kit Emergenza 1h (cod. 2)

Kit Emergenza 3h (cod. 3)

Kit dimmerabile 1-10V (cod. 4)

Kit dimmerabile DALI (cod. 5)

\* Le misure riportate sono puramente indicative. I seguenti articoli sono infatti personalizzabili a seconda delle esigenze tecniche ed estetiche del cliente.

Richiedere un preventivo.

### STRUCTURE

The body is made of steel sheet thickness 0,6mm. Steel diffusor frame with stainless screws. White powder coating RAL 9003. Waterproof gasket. Series 4109 for false ceiling with visible structure.

Series 4111 suitable for installation in false ceilings with exposed warping.

Series 4131 suitable for installation in false ceilings with hidden warping.

Series 4110 suitable for ceiling installation.

All the recessed version are equipped with adjustable brackets with suspension hole.

Special false ceiling version available on request.

### OPTICS

Diffusor in polycarbonate with conical microprism.

Luminance with <3.000 cd/m<sup>2</sup> radial >65°, UGR<19.

Compliant to the UNI EN 12464-1 and D.Lgs. 81/2008 rules.

Photobiological safety risk exempt (RG0).

### POWER

High efficiency LED modules, power factor >0,95.

Lifetime L85/B10/CO: 90.000 ore (Tp 25°C).

Colour 4.000°K, CRI (color rendering index) >90, initial tolerance MacAdam SDCM 2.

3.000°K or 5.000°K version available on request. Power supply 230V/50Hz. LED driver included.

### ACCESSORIES

Emergency kit 1h (code 2)

Emergency kit 3h (code 3)

Dimmable 1-10V kit (code 4)

Dimmable DALI kit (code 5)

\*The data are not binding. These products, in fact, are completely customizable according to the technical and stylist needs.

Required a quotation.

230V 50/60Hz



IK07

IP66

### Aseptic LED Recessed

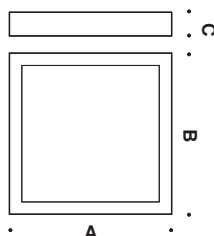

CRI>90

DRIVER INCLUDED



colour	W max	Vac	lm TC=25°C	lm output	K	A mm.	B mm.	C mm.	Kg	CELL
[B]	20	230	3.200	2.620	4000	295	595	90	3	4111.204
[B]	40	230	6.400	5.360	4000	595	595	90	3,50	4111.404
[B]	60	230	9.600	6.604	4000	595	595	90	3,50	4111.604
[B]	50	230	8.000	5.445	4000	295	1.195	90	3,90	4111.504
[B]	100	230	15.000	12.889	4000	595	1.195	90	5,00	4111.104
[B]	40	230	6.400	5.360	4000	598	598	90	3,50	4131.404
[B]	60	230	9.600	6.604	4000	598	598	90	3,50	4131.604
[B]	50	230	8.000	5.445	4000	298	1.198	90	3,90	4131.504
[B]	100	230	15.000	12.889	4000	598	1.198	90	5,00	4131.104

### Clean LED Plafone



colour	W max	Vac	lm TC=25°C	lm output	K	A mm.	B mm.	C mm.	Kg	CELL
[B]	20	230	3.200	2.620	4000	300	600	80	3,50	4110.204
[B]	40	230	6.400	5.360	4000	600	600	80	4	4110.404
[B]	60	230	9.600	6.604	4000	600	600	80	4	4110.604
[B]	50	230	8.000	5.445	4000	300	1.200	80	4,30	4110.504
[B]	100	230	15.000	12.889	4000	600	1.200	80	5,50	4110.104

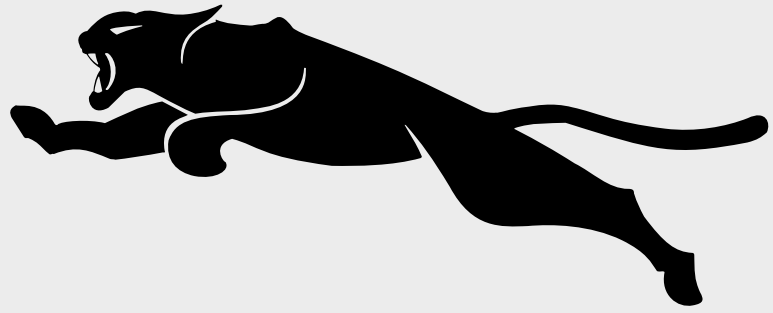

Nasce nel 1967 dalla passione e dall'ingegno di Giuseppe Pisati e oggi dai suoi nipoti Joseph, Julius e Jodie.

Il solido know-how nel campo della componentistica ha permesso a **Relco** di andare oltre, sviluppando una propria linea di apparecchi di illuminazione con più di 200 prodotti (2500 referenze), da utilizzare sia in outdoor che indoor. Molti dei nostri progetti sono consultabili nel sito:

[www.relcogroup.com](http://www.relcogroup.com)

It was born in 1967 from the passion and ingenuity of Giuseppe Pisati and today from his grandchildren Joseph, Julius and Jodie.

The solid know-how in the field of components has allowed Relco to go further, developing its own line of lighting fixtures with more than 200 products (2500 references), to be used both indoors and outdoors. Many of our projects can be consulted on the site:

[www.relcogroup.com](http://www.relcogroup.com)



## SERVIZIO AL CLIENTE - SERVICE FOR THE CUSTOMERS



### Consulta il nostro sito ottimizzato per tablet e smartphone

Dovunque tu sia potrai avere informazioni dettagliate su: prodotti, punti vendita, informazioni tecniche e commerciali, e potrai effettuare il download di cataloghi, schede tecniche e listini aggiornati in tempo reale.

### Check out our website designed for tablets and smartphones

Wherever you are, you will be able to access detailed information on: products, outlets, technical and marketing information, and you will be able to download catalogues and price lists updated in real time.



### Progettazione

La certificazione fotometrica dei nostri apparecchi viene sempre effettuata da un laboratorio fotometrico esterno. Efficienza luminosa e "lm Output" sono quindi il risultato di un ente terzo in alcun modo vincolato a Relco S.r.l. I progetti illuminotecnici sviluppati da Relco mettono a disposizione dei clienti le soluzioni più efficaci per esigenze spesso molto complesse. La definizione di ogni progetto determina un'autentica partnership tra le parti. La nostra realtà è a completa disposizione di progettisti che realizzano lavori con un alto profilo tecnologico: [projects@relcogroup.com](mailto:projects@relcogroup.com)

### Project

The lumen output performance of our lighting fixtures is always tested by third party accredited laboratories. The fixture efficiency and lm output are the results attested by a third party laboratory which is not bonded to Relco S.r.l. The lighting projects developed by Relco make the most efficient solutions to very complex issues available to customers. Defining each project results in an authentic partnership between the parties. Our company is at the full service of designers working on highly technological projects: [projects@relcogroup.com](mailto:projects@relcogroup.com)

## Confort visivo - Visual confort



### Controllo dell'abbagliamento

L'illuminazione degli spazi operativi in un'ottica smart, deve essere in grado di migliorare il senso di benessere di chi lavora seguendo le necessità degli utenti finali.

I sistemi di regolazione di **RELCO** consentono di trovare il giusto equilibrio tra luce artificiale e luce naturale proveniente dall'esterno.

Ciò consente di dare sostegno al bioritmo umano e creare le migliori condizioni visive per ogni attività.

Un ambiente confortevole sotto il profilo illuminotecnico incoraggia la creatività delle persone che lo abitano.

Relco offre soluzioni illuminotecniche globali, in grado di offrire valore aggiunto all'unione tra luce e architettura.

Ampia scelta di apparecchi LED e sistemi di comando per le applicazioni più svariate dell'illuminazione professionale di: uffici e istituti didattici, negozi, hotel e wellness, salute e cura, arte e cultura, industria e tecnica.

Relco sa trovare il giusto equilibrio fra qualità della luce ed efficienza energetica sviluppando soluzioni illuminotecniche su misura.

**Veniamo incontro alle vostre esigenze specifiche e alle necessità degli utenti, senza mai perdere di vista l'obiettivo di trovare la luce migliore per l'uomo e per l'ambiente.**

### Glare control

*The lighting of the work areas from a smart perspective must be able to improve the well-being of those who work according to the needs of end users.*

*The RELCO regulation systems allow the right balance to be found between artificial light and natural light coming from outside.*

*This allows us to support human biorhythm and create the best visual conditions for any activity.*

*A comfortable environment in terms of lighting encourages the creativity of the people who live in it.*

*Relco offers global lighting solutions, able to offer added value to the combination of light and architecture.*

*A wide selection of LED fixtures and control systems for various professional lighting applications: offices and educational institutions, shops, hotels and wellness, health and care, art and culture, industry and engineering.*

*Relco knows how to find the right balance between quality of light and energy efficiency by developing customised lighting solutions.*

***We meet your specific needs and users' needs, without ever taking our eyes off the goal of finding the best light for humans and the environment.***

### ▶ UGR<... Classificazione valori UGR in funzione delle applicazioni. UGR value classification based on application.

▶ UGR≤16	<b>Applicazioni molto impegnative</b> (disegni tecnici, lavoro a videoterminale). <b>Highly demanding applications</b> (technical drawings, working with video display terminals).
▶ UGR≤19	<b>Uffici e scuole</b> (lettura, scrittura, riunioni). <b>Offices and schools</b> (reading, writing, meetings).
▶ UGR≤22	Applicazioni industriali, artigianato. <b>Industrial, artisanal applications.</b>
▶ UGR>28	Abbagliamento elevato. <b>High glare.</b>

#### Fattore di abbagliamento UGR<19

Valore contemplato secondo la norma  
(coefficiente di riflessione: soffitto 0,7 - pareti 0,5).

#### Factor glare UGR<19

Value calculated according to the standard  
(reflection coefficient: ceiling 0.7 - walls 0.5)

L'UGR è l'indicatore dell'abbagliamento diretto derivante dall'impianto di illuminazione.

La norma Europea per l'illuminazione dei posti di lavoro in interni **UNI-EN12464-1** richiede un valore UGR specifico per ogni applicazione, compreso tra 10 e 30. Più è basso il valore, minore è l'abbagliamento.

Il valore esatto di tale indice è da calcolare su progetto in quanto dipende dalla disposizione degli apparecchi illuminanti, dalle caratteristiche dell'ambiente (dimensioni, riflessioni) e dal punto di osservazione.

*UGR is the indicator to assess the direct glare coming from a lighting system.*

*The UNI-EN12464-1 European standard for lighting indoor workplaces requires a specific UGR value for every application, ranging between 10 and 30. The lower the value, the lower the glare.*

*The exact value of this rating must be calculated in the design, as it depends on how the lighting fixtures are arranged, the features of the space (dimensions, reflections), and the viewpoint.*

# Prestazioni di alto livello - High level performances

## Aspettativa di vita del LED e suo decadimento LED service life expectancy and deterioration

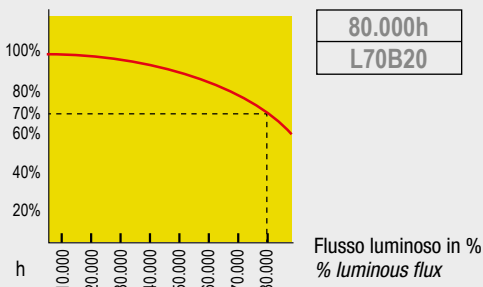

I LED diminuiscono gradualmente il loro flusso luminoso iniziale fino ad esaurirsi completamente in un periodo molto lungo. La durata di vita utile, indica la percentuale di decadimento del flusso luminoso (parametro "L") riferita ad un numero di ore utili di funzionamento. Il parametro "B" seguito da un valore normalmente compreso tra 10 e 50, indica la percentuale di componenti che, raggiunte le ore utili di funzionamento, non mantengono le caratteristiche di flusso luminoso dichiarate; ad esempio 80000h L70B20 vuol dire che l'80% dei moduli LED fornisce il 70% del flusso luminoso iniziale dopo 80000h di funzionamento.

The drop in LED flux is represented by acronym L70, which means flux at 70%. Value (B) followed by a value between 10 and 50 indicates the quality of the component being used, defining the percentage of LED that maintain the declared characteristics when the 80,000 hours have elapsed. Declared LED (L70B20) indicates that when 80,000 hours have elapsed, 80% (B20) of the LEDs have 70% of the flux they had at the beginning of their service life.

## Pittogramma Low Flicker Low Flicker pictogram



Apparecchio con flicker molto basso  
Product with a very low flicker

Flicker indica lo sfarfallio visibile a occhio nudo. Può verificarsi a frequenze inferiori a 60hz e dipende da diversi fattori tra cui il ripple di uscita degli alimentatori. E' importante definire "low" non vuol dire esente, ma ridotto.

Flicker is a common issue with LED lamps. It can occur at frequencies below 60 Hz and depends on several factors, such as the ripple emitted by drivers. Furthermore, "flicker-free" does not mean "without" but rather "very low".

## RIPPLE FREE

Il **RIPPLE FREE** è un esempio dello sviluppo e ricerca sui prodotti Relco Lighting & Components. I driver LED Relco Lighting & Components sono forniti di un circuito multistadio per alimentare i LED con una corrente perfetta. Con il termine RIPPLE si fa riferimento alla dimensione della forma d'onda della corrente d'uscita del driver LED. Dove il ripple è presente la forma d'onda si deforma con conseguente surriscaldamento del LED che ne riduce la vita media. Inoltre il ripple, causa oscillazioni della luce provocando disturbi durante le riprese video. Sullo schermo verranno visualizzate una serie di righe scure in movimento verso il basso che renderanno l'immagine illeggibile. Quando si alimentano i LED con LED Driver RIPPLE FREE è possibile raggiungere le massime prestazioni ed efficienza luminosa, con la minima dissipazione di calore.

The **RIPPLE FREE** is an example of R&D on the Relco Lighting & Components products. The Relco Lighting & Components LED drivers are provided with multistage circuit to feed the LEDs with a perfect current. The term RIPPLE refers to the dimension of the wave form of the LED driver output current, when present this deforms the same wave form with consequent overheating of the LED with reduced average life. Also this phenomenon, cause of light oscillations, results in effects while shooting videos, where the images appear to be cut with several black lines making shooting impossible. When you feed the LEDs with Led driver RIPPLE FREE you can achieve maximum performance and light efficiency, with minimal heat dissipation.

## Norme Europee di certificazione elettrica European norms electrical certification



Tutti i prodotti sono costruiti nel rispetto delle Normative Europee (2014/35/UE, 2006/95/CE, 2014/30/UE, 2004/108/CE, 2009/125/CE) come riportato nella dichiarazione di conformità UE.

All products are manufactured in compliance with European Directives (2014/35/UE, 2006/95/CE, 2014/30/UE, 2004/108/CE, 2009/125/CE) as reported in the UE conformity declaration.

## Sicurezza fotobiologica Photobiological safety



La sicurezza fotobiologica è determinata dalla quantità di radiazioni emesse dalle sorgenti luminose con lunghezza d'onda compresa tra 200nm e 3000nm.

Un'esposizione eccessiva alle radiazioni, può essere causa di danni per l'uomo. La norma EN62471 definisce una classificazione delle sorgenti in gruppi di rischio. RG0 Ethr: apparecchi che non presentano rischio fotobio-logico ai fini della Norma EN62471. Richiedere in sede la distanza dal punto di osservazione, se necessaria.

RG0: assenza di rischi fotobiologici ai fini della norma EN62471.

RG1 (gruppo di rischio basso): la sorgente non provoca rischi dovuti a normali limitazioni di funzionamento sull'e-sposizione.

RG2 (gruppo di rischio moderato): la sorgente non pro-voca un rischio in seguito ad una reazione istintiva guar-dando fonti molto luminose o in seguito ad una sensazio-ne di disagio termico.

We often read about photo-biological safety in lighting design. This very important factor is determined by the amount of radiations emitted by all the sources with a wave length ranging between 200 nm and 3000 nm. Excessi-ve radiation exposure can be harmful for human health. The EN62471 standard classifies light sources into risk groups. Risk Group 0 (RG0 Ethr): luminaires are exempt from photobiological risks in compliance with standard EN 62471. If necessary, contact our customer service for the observation distance.

RG0 (exempt risk group): the lighting source is exempt from risks in compliance with EN 62471 Standard.

RG1 (low risk group): no risk deriving from a limited emission of radiation.

RG2 (moderate risk): the lighting source does not pose hazards because of our aversion response to very bright light sources, or due to the fact that we would experien-ce thermal discomfort.



ENEC è un Marchio Europeo di Certificazione di prestazione, è stato istituito in sede CENELEC (Comitato europeo di normazione elettrotecnica) dagli organismi di certificazione elettrica che hanno aderito ad un accordo denominato "LUM AGREEMENT" per il mutuo riconoscimento di un unico marchio "ENEC" equivalente ai singoli marchi degli organismi aderenti. ENEC è un marchio ad alto valore tecnico basato su severi criteri di certificazione che offre garanzie oltre che sulla sicurezza elettrica anche sulle prestazioni dell'apparecchio elettrico. A fianco del marchio ENEC viene posto un numero che identifica l'organismo che ha rilasciato la certificazione.

ENEC is a European Certification mark for performance established at CENELEC (European Committee for Electrotechnical Standardization) by electrical certification institutions. These bodies have entered an agreement called "LUM AGREEMENT" for the mutual recognition of a sole mark, "ENEC", equivalent to the single marks of the adhering institutions. ENEC is a high value technical mark based on strict certification criteria which offers a guarantee not only on electrical safety but also on the performance of the electrical apparatus.

## Certificazioni ISO 9001 ISO 9001 certification



# Protezione - Protection

## Cos'è la sovratensione? What is a surge?

È un rapido innalzamento del valore di tensione tra parti di diverse polarità e tra queste e la terra.

Alcune sovratensioni possono superare la soglia d'isolamento o di immunità dei componenti elettronici provocandone il disservizio.

*A surge is a rapid increase in voltage on a power line between parts of opposite polarities and/or the ground. Some power surges may exceed the isolation or immunity threshold of electronic components causing it to fail.*

## Dispositivi di protezione Surge protector

Per fare fronte ai danni causati da sovracorrenti o sovratensioni viene utilizzato un dispositivo di protezione conforme alla norma EN 61547 contro i fenomeni impulsivi atto a proteggere il modulo LED e il relativo alimentatore.

*To protect lighting installations from surge, i.e. the rapid increase in voltage between parts of opposite polarities and/or the ground, Relco Components & Lighting has equipped its luminaires with an EN 61547 compliant surge protector, capable of protecting the LED module and their related driver from voltage spikes, damages caused by lightning and overcurrents.*

## Modalità di protezione Protection modes

**Modo differenziale:** Surge tra i conduttori di alimentazione, tra il conduttore di sovratensione verso quello di neutro. Sostanzialmente, tra fase (L) e neutro (N) non si presentano sovratensioni molto elevate perché i picchi di tensione vengono soppressi da altre apparecchiature collegate alla rete elettrica; di conseguenza è sufficiente una protezione più bassa da sovratensione. A seconda della famiglia di prodotto, Relco Lighting & Components integra quindi una protezione fino a 6 kV.

**Modo comune:** Surge tra i conduttori di alimentazione, L/N, verso la terra o il corpo dell'apparecchio se quest'ultimo è in classe II (se questo è installato su palo metallico). Le sovratensioni di modo comune sono ad esempio generate dai fulmini, e possono raggiungere valori molto elevati. A seconda della famiglia di prodotto, Relco Components & Lighting integra una protezione fino a 8 kV (a richiesta 10kV).

**Differential mode:** Surge between power conductors, between the phase conductor to the neutral conductor. Substantially, between phase (L) and neutral (N) no substantial surges are present because voltage peaks are suppressed by other equipment connected to the power line; as a consequence a lower surge protector is sufficient. Depending on the type of product, Relco Lighting & Components provides a protection from surges of up to 6kV

**Common mode:** Surge between power conductors, L/N, to the ground or the body of the luminaire if it is classified in class II (i.e. it is installed on a metal pole). Overvoltage in the common mode are generated by lightning strikes and may reach very high levels. Depending on the type of product, Relco Lighting & Components provides a protection from surges of up to 8 kV (10kV upon request).

## Gli effetti delle sovratensioni The effects of surges

Sovratensioni di ridotta entità non comportano necessariamente l'immediato guasto di moduli LED o driver (se pur con protezione 4kV), se però si verificano ripetutamente possono provocare il deterioramento precoce dei LED e, di conseguenza, una durata ridotta. Sovratensioni elevate (caduta dei fulmini) si traducono invece nel guasto immediato dei moduli LED o dei driver. Nei moduli LED e nei driver le sovratensioni provocano correnti elevate (impulsi di energia). Questo fenomeno può provocare:

- guasto parziale o totale dei moduli LED o dei driver
- deterioramento accelerato dei moduli LED diminuendone la durata
- possibile guasto anche dell'interfaccia di comando

*Small overvoltages do not necessarily lead to the immediate failure of LED modules or drivers (albeit with 4kV protection), but if they occur repeatedly they can cause premature deterioration of the LEDs and, consequently, a shortened life span. High overvoltages (lightning strikes), on the other hand, result in immediate failure of the LED modules or drivers. In LED modules and drivers, overvoltages cause high currents (energy pulses). This phenomenon can cause:*

- partial or total failure of the LED modules or drivers
- accelerated deterioration of the LED modules reducing their duration
- possible failure of the command interface as well



## Riprese televisive con illuminazione a LED TV footage with LED lighting

Durante una trasmissione televisiva, si può notare un fastidioso sfarfallio delle immagini a rallentatore. Il fenomeno di "flicker", affatica la vista e distrae lo spettatore. Le cause dello sfarfallio possono essere: frequenza della modulazione, fluttuazione di tensione e numero di fotogrammi al secondo. Generalmente uno sfarfallio inferiore al 5% non da alcun fastidio durante le riprese fino a 150 fotogrammi al secondo. Un sistema di illuminazione con un fattore di sfarfallio (FF) inferiore a 5% è in grado di eliminare il disturbo percepito.

*During a broadcast it is not uncommon to perceive an annoying flicker especially during slow motion. This flicker is distracting and should be eliminated where possible. The circumstances that produce the flicker vary upon the frequency modulation, voltage and camera frame rate.*

*The table below provides a general rule of flicker factor values produced by various lighting systems. A flicker factor of less than 5% will generally not cause problems for slow motion replays at up to 150 frames per second. A lighting system with a flicker factor of less than 5% will eliminate the perceived flicker at most frame rates per second used within the sports television industry.*

*The acceptable level of flicker factor (FF) is indicated in the Illuminance Category Tables.*

Tabella dei valori Flicker Factor (FF)	
Tipo di illuminazione	Valore FF (indicativo)
Luce naturale	0%
Apparecchi LED. La % di sfarfallio dipende dal tipo di LED e alimentatore utilizzati	< 3%
Lampade a scarica con alimentatori ad alta intensità	< 4%
Lampade a scarica con alimentatori magnetici trifase in grado di emettere luce uniforme	8 - 20%
Lampade a scarica con alimentatori elettromagnetici monofase	30 - 50%

Flicker Factor reference table (FF)	
Lighting type	FF value (indicative)
Daylight	0%
LED Luminaires % of flicker depend upon the type of LED power supply	< 3%
Discharge lamps with high frequency ballasts	< 4%
Discharge lamps with 3-phase magnetic ballasts for uniform light	8 - 20%
Discharge lamps with single-phase magnetic ballasts	30 - 50%

# Protezione IP - IP Protection

Schema relativo alle cifre che compongono il grado IP	
<b>Significato relativo alla prima cifra del grado di protezione</b>	
1	Protezione da oggetti solidi maggiori di 50mm
2	Protezione da oggetti solidi maggiori di 12mm
3	Protezione da oggetti solidi maggiori di 2,5mm
4	Protezione da oggetti solidi maggiori di 1mm
5	Protezione da polveri
6	Protezione forte da polveri
<b>Significato relativo alla seconda cifra del grado di protezione</b>	
1	Protezione da gocce d'acqua
2	Protezione da gocce d'acqua deviate fino a 15°
3	Protezione da vapori d'acqua
4	Protezione da spruzzi d'acqua
5	Protezione da getti d'acqua
6	Protezione da getti d'acqua forti o mareggiate
7	Protezione contro l'immersione
8	Protezione contro l'immersione continua
Questo semplice schema ci suggerisce quindi che qualsiasi prodotto di illuminazione dovrà essere scelto in base al suo grado di protezione IP. Tale grado sarà il risultato della valutazione delle caratteristiche del luogo di installazione del medesimo prodotto e del suo impiego.	

Diagram of the numbers that make up the IP rating	
<b>Meaning of the first numbers of the protection rating</b>	
1	Protection from solid objects larger than 50 mm
2	Protection from solid objects larger than 12 mm
3	Protection from solid objects larger than 2.5 mm
4	Protection from solid objects larger than 1 mm
5	Protection from dust
6	Strong protection from dust
<b>Meaning of the second numbers of the protection rating</b>	
1	Protection from dripping water
2	Protection from dripping water when tilted up to 15°
3	Protection from spraying water
4	Protection from splashing water
5	Protection from water jets
6	Protection from powerful water jets or sea storms
7	Protection from immersion
8	Protection from continuous immersion
This simple diagram suggests that any lighting fixture must be chosen based on its IP rating. This rating will be the result of an assessment of the characteristics of the place of installation of the product itself and of its use.	

Esempi di IP presenti su alcuni apparecchi per interni ed esterni	
<b>IP44</b>	Il grado IP 44 garantisce la protezione contro la penetrazione di corpi solidi maggiori di 1 mm. Permette la protezione contro la penetrazione di liquidi da gocce, vapori o spruzzi in qualsiasi direzione
<b>IP54</b>	Il grado IP54 garantisce la protezione totale alla penetrazione di corpi solidi, di liquidi da gocce, vapori o spruzzi in qualsiasi direzione. Questo grado di isolamento non permette la penetrazione di polveri e liquidi non deve danneggiare l'apparecchiatura
<b>IP55</b>	Il grado IP55 garantisce la protezione totale alla penetrazione di corpi solidi, la penetrazione di liquidi da gocce, vapori, spruzzi e getti d'acqua in qualsiasi direzione. Inoltre non deve permettere la penetrazione di polveri e liquidi non deve danneggiare l'apparecchiatura.
<b>IP65</b>	Il grado IP65 garantisce la protezione totale alla penetrazione di corpi solidi, la penetrazione di liquidi da gocce, vapori, spruzzi e getti d'acqua in qualsiasi direzione. In questo grado di protezione, la penetrazione liquidi non deve danneggiare l'apparecchiatura
<b>IP66</b>	Il grado IP66 è garanzia di protezione totale alla penetrazione di corpi solidi e polveri, di penetrazione di liquidi da spruzzi, mareggiate e forti getti d'acqua in qualsiasi direzione. Anche in questo caso la penetrazione liquidi non deve danneggiare l'apparecchiatura
<b>IP67</b>	Il grado IP67 garantisce la protezione totale alla penetrazione di corpi solidi e polveri, la protezione contro l'immersione in acqua momentanea per 30 minuti a 1 metro di profondità.
<b>IP68</b>	Il grado IP68 permette una protezione totale alla penetrazione di corpi solidi e polveri, contro l'immersione in acqua permanente a 1 metro di profondità.
<b>IP68-xx</b>	Il grado IP68-XX permette una protezione totale alla penetrazione di corpi solidi e polveri, contro l'immersione in acqua permanente a xx metri di profondità

Examples of IPs present on some indoor or outdoor lamp	
<b>IP44</b>	The IP 44 rating ensures protection from penetrating solid bodies greater than 1 mm. It also ensures protection from dripping, spraying and splashing water in any direction
<b>IP54</b>	The IP 54 rating ensures complete protection from penetrating solid bodies as well as dripping, spraying and splashing water in any direction. This insulation rating ensures protection from dust ingress and penetrating liquids which must not damage the equipment.
<b>IP55</b>	The IP 55 rating ensures complete protection from penetrating solid bodies as well as from dripping, spraying, splashing water and water jets in any direction. Moreover, it must protect from dust ingress and penetrating liquids which must not damage the equipment
<b>IP65</b>	The IP 65 rating ensures complete protection from penetrating solid bodies as well as dripping, spraying, splashing water and water jets in any direction. With this insulation rating, penetrating liquids must not damage the equipment.
<b>IP66</b>	The IP 66 rating ensures complete protection from penetrating solid bodies and dust ingress, as well as from dripping, spraying, splashing water, sea storms and strong water jets in any direction. In this case as well, penetrating liquids must not damage the equipment
<b>IP67</b>	The IP67 rating ensures complete protection from penetrating solid bodies and dust ingress, and from temporary immersion in water for 30 minutes at a depth of 1 metre
<b>IP68</b>	The IP68 rating ensures complete protection from penetrating solid bodies and dust ingress, from permanent immersion in water at a depth of 1 metre
<b>IP68-xx</b>	The IP68-xx rating ensures complete protection from penetrating solid bodies and dust ingress, from permanent immersion in water at a depth of xx metres

## Sistemi di controllo Control systems

1-10Vdc

Controllo dell'illuminazione in modo facile, elegante ed energeticamente efficiente con un dimming continuo. Permette una riduzione dei costi dell'illuminazione e del consumo di energia. Per tutti i componenti necessari vi consigliamo di fare riferimento al catalogo Relco Components scaricabile dal sito.

*Easy access mode for controlling the illumination, elegant and energy-efficient through a continuous dimming. It permits a sensible cost-reduction of the illumination energy-consume. For all required components, please refer to the Relco Components catalogue which can be downloaded from the website.*



### Digital Address Lighting Interface

La regolazione mediante l'interfaccia digitale DALI (Digital Addressable Lighting Interface) rappresenta l'evoluzione della regolazione analogica. Questa interfaccia è stata sviluppata comunemente dai più importanti produttori di alimentatori elettronici per realizzare uno standard di regolazione comune all'industria mondiale illuminotecnica.

#### Caratteristiche principali della REGOLAZIONE DALI

- Memorizzazione di scenari luminosi;
- Messaggi per lampada guasta o a fine vita;
- Nessun problema con le fasi della rete;
- Nessuna necessità di rispettare la polarità dei cavi di regolazione;
- Possibilità di assegnare un indirizzo univoco ad ogni dispositivo connesso.

*Regulation by means of DALI (Digital Addressable Lighting Interface) digital interface represents an evolution in analogical regulation. This interface has been jointly developed by the most important producers of electronic drivers to create a standard regulation for the lighting engineering industry all over the world.*

#### Main features of the DALI REGULATION

- Memory function of light scenes;
- Messages for breakdown or end of life of the lamp;
- No problem with the phases of the supply mains;
- No need to observe the polarity of the regulation cables;
- Possibility to assign a unique address to each connected device.



Sistema di controllo con l'utilizzo di pulsanti standard per la gestione della tensione di rete al fine di regolare il flusso luminoso. Con una breve pressione si potranno accendere, spegnere e regolare i driver collegati. Il funzionamento può essere effettuato da più punti. Soluzione integrabile con sensore di luce.

*Control system with the use of standard buttons for managing the mains voltage in order to adjust the luminous flux. With a short press the connected drivers can be switched on, off and adjusted. Operation can be carried out from several points. Solution that can be integrated with light sensor.*

Wireless



Sistema di controllo puntuale dell'impianto mediante tecnologia senza la necessità dell'installazione di cavi elettrici.

La gestione è possibile mediante telecomando e/o smartphone.

*Thorough installation control system via technology not requiring electrical cables to be laid.*

*Management is possible via remote control and/or smartphone.*



DMX

Protocollo per illuminazione dinamica.

Il tempo di reazione è immediato e il numero di apparecchi che si può controllare è praticamente illimitato. DMX può essere utilizzato anche per la dimmerazione delle luci di impianti sportivi.

DMX consente un'intera gamma di effetti scenici; il monitoraggio di ogni apparecchio di illuminazione e una configurazione facile da eseguire attraverso le funzioni DMX autoindirizzanti.

*Dynamic lighting protocol.*

*The reaction time is immediate and the number of devices that can be controlled is practically unlimited. DMX can also be used for dimming the lights of sports facilities.*

*DMX allows a whole range of scenic effects; the monitoring of each luminaire and an easy configuration through the self-addressing DMX functions.*



#### Sensori di luminosità/presenza

Consentono un utilizzo intelligente della luce di spazi altrimenti difficilmente gestibili, ottenendo così importanti risparmi di energia.













L'uso dei sensori è consigliato in ambienti in cui vi sia un'occupazione saltuaria o dove è necessario un livello di illuminamento costante.













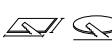



#### Brightness/presence sensor

*They do permit a very flexible utilization of the light in difficulties spaces, handled by a stable concept of illumination.*

*In addition, they do permit the easy handling and control of the in line with the different needs, obtaining important energy saving.*

# Legenda simboli - Symbols legend

<b>colour</b>	Colore apparecchio - <i>Surface finish</i>
<b>W</b>	Watt
<b>pcs</b>	Quantità minima ordinabile - <i>Minimum quantity to be ordered</i>
<b>Kg</b>	Peso netto in Kg del prodotto - <i>Net product weight in Kg</i>
<b>time/flux</b>	Autonomia/fluxo - <i>Duration/flux</i>
<b>A</b>	Ampere
<b>Hz</b>	Frequenza - <i>Frequency</i>
<b>V</b>	Volt
<b>colour</b>	Colore apparecchio - <i>Lamp colour</i>
<b>time/flux</b>	Autonomia/fluxo - <i>Duration/flux</i>
<b>Hz</b>	Frequenza - <i>Frequency</i>
<b>LED</b>	Tipo di LED - <i>LED type</i>
<b>S</b>	Corpo apparecchio - <i>Body</i>
<b>S + L</b>	Corpo apparecchio + lampada - <i>Body + bulb</i>
<b>CELL</b>	Corpo apparecchio + alimentazione elettronica + scheda LED <i>Body + driver + circuit LED</i>
<b>CELL-E</b>	Corpo apparecchio + alimentazione elettronica + lampada + emergenza <i>Body + driver + Bulb + emergency kit</i>
<b>Art. S</b>	Installazione a sospensione <i>Suspended installation</i>
<b>Art. R</b>	Installazione ad incasso <i>Recessed installation</i>
<b>Art. C</b>	Installazione a plafone <i>Ceiling installation</i>
	Rotazione dell'apparecchio sull'asse verticale e orizzontale <i>Rotation of the device on the vertical and horizontal axis</i>
	Dotato di vetro di protezione temperato <i>Equipped with tempered protection glass</i>
	Apparecchio costruito con materiali riciclabili <i>This device is made of recyclable materials</i>
	Apparecchio che resiste alla prova del filo incandescente <i>The device passes the glow wire test</i>
	Con isolamento funzionale in ogni parte e terminale o morsetto di terra se fisso <i>With functional isolation in each part and terminal or ground clamp if fixed</i>
	Con doppio isolamento, senza dispositivi per la messa a terra <i>With double insulation, without ground devices</i>
	Apparecchio in bassa tensione di sicurezza. <i>Safety low voltage device.</i>
	Temperatura ambiente di funzionamento - <i>Operating ambient temperature</i>
	Indice di Resa Cromatica <i>Color Rendering Index</i>
	Apparecchi calpestanti e/o carrabili con bassa emissione di calore sul diffusore. <i>Walkover or/and drive over fitting with low heat emission on the diffuser</i>
	HIGH EFFICIENCY
	Prodotto dotato di kit d'emergenza <i>Article with emergency kit</i>

















<b>Lm/W</b>	Efficienza lm/W apparecchio - <i>Efficiency lm/W unit</i>
<b>nominal lm tc = 25°C</b>	Efficienza della sorgente luminosa - <i>Efficiency of the light source</i>
<b>lm output *</b>	Efficienza luminosa effettiva dell'apparecchio <i>Effective luminous efficiency of the fixture</i>
	Prodotto con certificazione CB <i>Product with CB certificate</i>
	Prodotto conforme alle direttive D.M. 11 Ottobre 2017 <i>In compliance with the directives D.M. 11 Ottobre 2017</i>
	Dimensioni foro incasso <i>Hole for fitting dimensions</i>
	Resistenza dell'apparecchio alla penetrazione di liquidi o solidi <i>Devices resistance to the penetration of liquids or solids</i>
	Grado di resistenza agli urti <i>Impact resistance degree</i>
	LED COB full color
	LED SMD singol color
	Resistenza dell'apparecchio alla penetrazione di liquidi o solidi <i>Devices resistance to the penetration of liquids or solids</i>
	LED COB FULL COLOR
<b>K</b>	Temperatura di colore in Kelvin <i>Kelvin colour temperature</i>
<b>3000K</b>	Temperatura di colore in Kelvin - luce calda <i>Kelvin color temperature - warm white</i>
<b>4000K</b>	Temperatura di colore in Kelvin - luce neutra <i>Kelvin color temperature - day lights</i>
<b>6000K</b>	Temperatura di colore in Kelvin - luce fredda <i>Kelvin color temperature - cool lights</i>
	A richiesta 4000K <i>On request 4000K</i>
	A richiesta 6000K - <i>On request 6000K</i>
<b>1-10Vdc</b>	Controllo dell'illuminazione in modo facile, con un dimming continuo. <i>Easy access mode for controlling the illumination, a continuous dimming.</i>
	Sistema di controllo della luminosità attraverso pulsanti NA  <i>Brightness control system through NO buttons </i>
	Driver incluso nel prodotto <i>Driver included in the product</i>
	Driver non incluso, da ordinare a parte <i>Not included driver, to be ordered separately</i>
	<b>Tutti gli apparecchi di illuminazione di questo catalogo utilizzano un Driver LED "MULTIPOWER". A richiesta, per quantità, è possibile cambiare in fabbrica la taratura della corrente e, di conseguenza potenza (W) e Lumen (Lm)</b> <b>All the luminaires in this catalog use a "MULTIPOWER" LED Driver. On request, for quantity, it is possible to change the current calibration in the factory and, consequently, power (W) and Lumen (Lm)</b>

\* Lm Output

La certificazione fotometrica dei nostri apparecchi viene sempre effettuata da un laboratorio fotometrico esterno. Efficienza luminosa e Lumen Output sono quindi il risultato di un ente terzo, in alcun modo vincolato a Relco S.r.l. Il Flusso luminoso output riportato indica il flusso uscente dell'apparecchio di illuminazione con una tolleranza  $\pm 10\%$  rispetto al valore indicato.  
*The photometric certification of our appliances is always carried out by an external photometric laboratory. Luminous efficiency and Lumen Output are therefore the result of a third party, in no way bound to Relco S.r.l. The reported output luminous flux indicates the output flux of the lighting fixture with a tolerance of  $\pm 10\%$  compared to the indicated value.*

# Legenda simboli - Symbols legend

Applicazione apparecchi - <i>Appliance application</i>	
	Adatto per installazione in luoghi di culto. <i>Suitable for installation in places of worship.</i>
	Adatto per installazione in Hotel, Alberghi e luoghi di soggiorno. <i>Suitable for installation in hotels and places to stay.</i>
	Adatto per installazione in aule scolastiche. <i>Suitable for installation in classrooms.</i>
	Adatto per installazione in uffici con stazionamento di addetti a videoterminale. <i>Suitable for installation in offices with employees working at video terminals.</i>
	Adatto per installazione in uffici, corridoi, sale riunioni. <i>Suitable for installation in offices, corridors, meeting rooms.</i>
	Adatto per installazione in palestre, centri sportivi. <i>Suitable for installation in gyms, sports centres.</i>
	Adatto per illuminazione di opere d'arte, quadri. <i>Suitable for lighting works of art, paintings.</i>
	Adatto per installazione in Ospedale. <i>Suitable for installation in hospitals.</i>
	Adatto per installazione in Ipermercati, Supermercati. <i>Suitable for installation in hypermarkets, supermarkets.</i>
	Adatto per installazione in negozi in genere. <i>Suitable for installation in shops in general.</i>
	Adatto per installazione in parcheggi. <i>Suitable for installation in car parks.</i>
	Adatto per installazione all'aperto, terrazzi anche scoperti. <i>Suitable for installation outdoors, even open terraces.</i>
	Adatto per installazione in bagni. <i>Suitable for installation in bathrooms.</i>
	Adatto per installazione in zone umide. <i>Suitable for installation in wet areas.</i>

Colore corpo apparecchi - <i>Luminaire body color</i>	
	Bianco - <i>White</i>
	Nero - <i>Black</i>
	Grigio - <i>Grey</i>
	Argento sabbato - <i>Sanded silver</i>
	Argento - <i>Silver</i>
	Alluminio lucido - <i>Polished aluminum</i>
	Trasparente - <i>Transparent</i>
	Cromo - <i>Chrome</i>
	Oro - <i>Gold</i>
	Argento lucido - <i>Polished Silver</i>
	Trasparente - <i>Transparent</i>
	Specchio - <i>Mirror</i>
	Vetro satinato - <i>Frosted glass</i>
	Vetro fumè - <i>Fumè glass</i>
	Cromo - <i>Chrome</i>
	Rame - <i>Copper</i>

## Apparecchi in emergenza - *Emergency wired luminaires*

### Apparecchi di illuminazione cablati in emergenza

Relco nella politica di offrire un servizio migliore alla clientela, ha deciso di utilizzare nei suoi apparecchi di illuminazione dotati di emergenza, solo **INVERTER PER EMERGENZA CON AUTOTEST.**

Le norme europee EN 1838, EN 60598-2-22, relative ai sistemi di illuminazione di emergenza, impongono che periodicamente, siano effettuati dei test per verificare sia il funzionamento sia l'efficienza (durata in emergenza) degli apparecchi di illuminazione che svolgono anche la funzione di illuminazione di emergenza. Questo costringe i manutentori dell'impianto ad interrompere la linea di alimentazione ed effettuare test con cadenza settimanale (test funzionale), e con cadenza trimestrale o annuale (test di autonomia).

Con i nostri kit di emergenza con autotest (conformi alla normativa europea EN 62034) queste prove vengono svolte automaticamente con cadenza programmabile in fase di installazione. Inoltre il nostro inverter analizza i tempi di normale accensione e spegnimento dell'apparecchio ed effettua (qualora possibile) i test nelle ore di assenza delle persone.

Eventuali anomalie sono segnalate tramite un indicatore (led) rosso verde.

A partire dal colore della segnalazione è possibile stabilire in maniera univoca gli eventuali problemi di funzionamento come evidenziato nella tabella seguente.

### Emergency wired luminaires

Relco in its policy of offering a better service to customers, has decided to use only **EMERGENCY INVERTER WITH SELF-TEST** in its luminaires equipped with emergency.





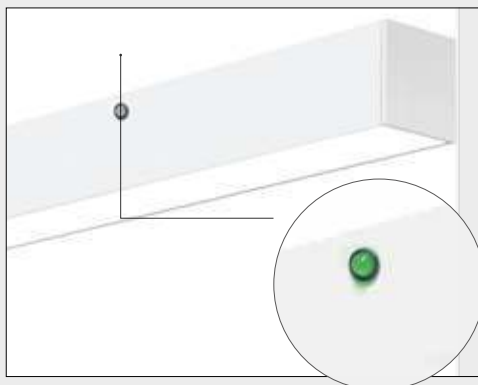

The European standards EN 1838, EN 60598-2-22, relating to emergency lighting systems, require that tests be periodically carried out to verify both the functioning and the efficiency (duration in emergency) of the lighting fixtures which also the emergency lighting function. This forces the system maintainers to interrupt the power supply line and carry out tests on a weekly basis (functional test), and on a quarterly or annual basis (autonomy test).

With our emergency kits with self-test (complying with European standard EN 62034) these tests are carried out automatically with a programmable cadence during installation.

Furthermore, our inverter analyzes the normal switching on and off times of the appliance and carries out (where possible) the tests in the hours when people are absent.

Any anomalies are signaled by a red-green indicator (led). Starting from the color of the signal, it is possible to unequivocally establish any functioning problems as shown in the following table.



Colore LED - <i>LED indication</i>	Stato - <i>Status</i>	
	Verde fisso - <i>Permanent Green</i>	Batteria carica o in carica - <i>Battery charge or charging</i>
	Verde lampeggiante - <i>Flashing Green</i>	Funzione TEST avviata - <i>TEST in progress</i>
	Verde lampeggiante lento (1s ON - 1s OFF) Slow flashing green (1s ON - 1s OFF)	TEST di autonomia avviato Autonomy TEST in progress
	Rosso fisso - <i>Permanent Red</i>	Lampada guasta - <i>Lamp failure</i>
	Rosso lampeggio veloce (0,1s ON - 0,1s OFF) Fast flashing Red (0,1s ON - 0,1s OFF)	Guasto circuito di ricarica - <i>Charging failure</i>
	Lampeggio Rosso lento (1s ON - 1s OFF) Slow flashing Red (1s ON - 1s OFF)	Batteria guasta - <i>Battery failure</i>
	Verde e Rosso OFF - <i>Green and Red OFF</i>	Emergenza ON - <i>Emergency ON</i>

# Termini e condizioni di garanzia - *Warranty terms and conditions*

## La garanzia è applicabile solo quando:

1. I prodotti sono installati, utilizzati e mantenuti in conformità alle specifiche tecniche indicate nella marcatura del prodotto (con riferimento specifico al voltaggio e alla temperatura di funzionamento), alle istruzioni fornite insieme al prodotto e alle norme vigenti.
2. L'installazione e la manutenzione sono eseguite da personale tecnico qualificato.
3. Il difetto segnalato pregiudica il funzionamento del prodotto.
4. Il prodotto non è stato in alcun modo modificato, alterato o trattato con agenti chimici o in qualsiasi altra maniera, senza previa autorizzazione scritta di Relco S.r.l.
5. Il prodotto oggetto della garanzia è messo a disposizione di Relco S.r.l. per ulteriori analisi tecniche e per il tempo necessario al suo svolgimento.
6. Il difetto deve essere denunciato per iscritto a Relco S.r.l. entro 30 (trenta) giorni dalla data del ricevimento dei prodotti (in caso di difetti apparenti) o dalla scoperta del difetto (in caso di difetti occulti).
7. La garanzia ha effetto immediato dalla data di acquisto e farà fede la data della fattura di vendita.
8. Periodi di garanzia superiori a 24 mesi potranno essere richiesti dall'acquirente e verranno accordati dopo aver valutato le condizioni di applicazione specifiche.

Nel caso in cui il difetto venga riconosciuto, Relco S.r.l. sceglierà, a sua discrezione, se riparare o sostituire il prodotto con lo stesso prodotto o con prodotti equivalenti, tenendo in considerazione l'evoluzione tecnica dei prodotti e dei loro componenti.

Qualsiasi intervento tecnico o sostituzione (parziale o completa) del prodotto effettuato in garanzia non darà comunque diritto a prolungamenti o rinnovi della stessa oltre i 5 (cinque) anni dalla data della fornitura, in quanto la relazione legale tra le parti non è rinnovata.

La riparazione o la sostituzione del Prodotto, non include costi o spese per la rimozione o reinstallazione. Relco S.r.l. non rimborserà alcuna perdita consequenziale subita a causa di un prodotto difettoso, come ad esempio costi di spedizione, costi di assemblaggio, costi di installazione in loco, perdita di profitto, costi complessivi degli acquirenti.

## Esclusioni e limitazioni

La presente garanzia non include:

- A. I costi e le spese della manodopera, costi e spese delle attrezzature magazzino e qualsiasi altro costo extra relativo e/o risultante da qualsiasi lavoro necessario per riparare il difetto (es. costi/spese del montaggio e smontaggio, trasporto degli apparecchi difettosi, da riparare e nuovi prodotti) saranno a carico del cliente.
- B. I componenti elettrici soggetti ad usura che sono assimilabili a materiale di consumo (ad esempio, batterie).
- C. I prodotti realizzati su specifica richiesta del cliente e da lui approvati.
- D. Danni al prodotto dovuti a negligenza, al trasporto o ad eventuali imprevisti e di prevedibili situazioni che non rientrino nelle normali condizioni di utilizzo di cui al punto 1 (ad esempio scariche elettriche e fulmini);

La presente garanzia speciale non si applica se l'apparecchio non è usato per lo scopo per cui è stato realizzato;

La presente garanzia non garantisce l'integrità della verniciatura quando il prodotto viene utilizzato in un ambiente salino o in presenza di agenti corrosivi. In nessun caso Relco S.r.l. sarà responsabile per danni accidentali, compensativi, consequenziali, indiretti, speciali o altri danni.

La responsabilità di Relco S.r.l. per un difetto del prodotto sarà in ogni caso limitata alla somma pagata per quel prodotto difettoso.

Il decadimento del flusso è un fenomeno previsto durante la vita del LED e è quindi non protetto da garanzia.

## Controversie Tecniche

In caso di controversia tecnica le parti sottoporranno il prodotto in contestazione a perizia di Esperto Terzo nominato di comune accordo o, in mancanza di accordo, dal Presidente del Tribunale di Milano.

La valutazione dell'esperto sarà vincolante per entrambe le Parti.

Le spese verranno sostenute dalle Parti in misura del 50% ciascuna.

## The conventional warranty applies only when:

1. The products are installed, used and maintained in accordance with the technical specifications reported on the product's marking (with specific reference to the operating voltage and temperature), with the instructions provided with the product and with current standards.
2. Installation and maintenance are carried out by qualified technical personnel.
3. The reported defect affects the operation of the products.
4. The product has not been in any way modified, altered or treated with chemicals or in any other way without the prior written consent of Relco S.r.l.
5. The product covered by the warranty is made available by Relco S.r.l. for further technical analyses and for the time required to conduct them.
6. The defect must be notified in writing to Relco S.r.l. within 30 (thirty) days from the date of receipt of the goods (in case of visible defects) or from the discovery of the defect (in case of hidden defects).
7. The warranty has immediate effect from the purchase date, the invoice date serving as proof;
8. Warranty periods exceeding 24 months may be requested by the Purchaser and will be agreed after assessing the specific application conditions.

In case of the defect is acknowledged by Relco S.r.l., the latter will choose at its discretion whether to repair or replace the product with the same product or with equivalent products, by taking into account the technical evolution of the products and of their components.

Any technical intervention or replacement (partial or complete) of the product made during the period covered by the warranty will not provide entitlement to extensions or renewals thereof beyond 5 (five) years from the date of supply, as the legal relationship between the parties has not been renewed.

The repair or replacement of the product does not include costs or expenses for removal or reinstallation. Relco S.r.l. shall not be held liable and therefore shall not refund any consequential loss suffered as a result of a defective product, such as costs and shipping, assembly costs, on-site installation costs, loss of profit, the total costs of the buyers.

## Exclusions and limitations

This commercial warranty does not include:

- A. Costs and expenses for labour, equipment/warehouse costs and expenses and any other extra cost relating to and/or resulting from any work needed to repair the defect (e.g. costs and expenses for assembly/disassembly, transportation of defective appliances to be repaired and new products will be held by the customer);
- B. Electrical components subject to wear that are considered wear material (e.g. batteries, etc.)
- C. Products manufactured based on specific customer request, and approved by him;
- D. Damage to the product due to negligence, transport, unforeseen and unforeseeable events that do not fall under the normal conditions of use of 1 (such as electric shocks and lightning).

This special warranty does not apply if the appliance is not used for the purpose it was manufactured for;

This warranty does not guarantee the paintwork will remain intact when the product is used in a saline environment or in the presence of corrosive agents. Relco S.r.l. will not, under any circumstances, be responsible for accidental, compensatory, consequential, indirect, special or other kind of damage. The responsibility for Relco S.r.l. for a product defect will be in any case limited to the amount paid for that defective product.

The depreciation of the flow is a phenomenon expected during the life of the LED and is therefore not protected by warranty.

## Technical disputes

In the event of a technical dispute, the parties will have the product examined by a third-expert appointed by mutual agreement or, if no agreement is reached, by the president of the Court of Milan.

The evaluation of the expert will be binding for both parties.

Each party will cover 50% of the expenses.

# Condizioni Generali di vendita - *General sales conditions*

Il presente listino sostituisce ed annulla tutte le precedenti edizioni.

*This price list replaces and cancels all previous editions.*

## Condizioni generali

### **Spedizione Italia:**

Per poter ottenere il portofranco è necessario effettuare un ordine di almeno Euro 1.500, diversamente il cliente avrà un addebito in fattura del 2.5%.

**Importo minimo fatturabile Euro 300.**

La merce sarà evasa nel rispetto della quantità di cubetto o relativi multipli. Per eventuali richieste di disimballo sarà applicato un sovrapprezzo del 10%.

### **Imballo cartone**

Gratis. La merce viaggia a rischio e pericolo del committente. Trascorsi 8 giorni dal ricevimento merce non si accettano contestazioni.

### **Pagamento**

Per i nuovi clienti ad avviso di merce pronta; per i clienti abituali trascorsi termini di pagamento concordati verranno addebitati gli interessi di mora.

Foro competente Milano.

### **Resi**

Prima di effettuare un reso è necessario richiedere e ottenere, a mezzo mail/fax, l'autorizzazione del nostro ufficio commerciale o del nostro agente di zona per concordarne le modalità. I resi inviati in porto assegnato e/o senza autorizzazione saranno respinti. Le riparazioni/sostituzioni vengono evase non prima di 30 giorni.

Quando il regolatore svolge funzioni vitali nell'impianto sarà necessario prevedere un'adeguata scorta o riserva fredda.

Non si effettuano sostituzioni anticipate.

Nel caso di errori di spedizione o di ordine, il prodotto deve essere reso imballato come all'origine.

### **Assicurazione RCP (responsabilità civile prodotti)**

I prodotti Relco S.r.l. sono marcati e in molti casi Omologati IMQ, VDE, ENEC ecc. per il dettaglio delle omologazioni vedi pagine interne. Tutti i prodotti Relco S.r.l. sono inoltre coperti da una speciale polizza RCP valida in tutto il mondo stipulata con una tra le più prestigiose compagnie di assicurazione.

**RELCO S.r.l.**, persegue una politica di continua ricerca e sviluppo, quindi si riserva di variare in qualsiasi momento e senza preavviso le caratteristiche dei prodotti illustrati. Le informazioni di questo catalogo svolgono un'azione esclusivamente informativa, ed essendo soggette a continue variazioni, non devono essere prese come un impegno da parte di Relco S.r.l.

Relco S.r.l. non si assume alcuna responsabilità per eventuali errori che si possono riscontrare nel presente catalogo. Nessuna parte di questo stampato può essere riprodotto, memorizzato, archiviato o trasmesso in qualsiasi forma o con qualsiasi mezzo elettronico, meccanico o altro, senza previa autorizzazione scritta di Relco S.r.l.

## General conditions

***Ex works minimum invoice charge € 2,500, otherwise the customer will be charged 2.5% on the invoice.***

***Minimum invoice charge 300 euros.***

***The goods will be processed according to cube-based amounts or relative multiples. A 10% charge will be applied on any unpacking requests.***

### **Cardboard packaging**

Free. Goods travel at the risk and peril of the client. Complaints must be submitted no later than 8 days after receipt of the goods.

### **Payment**

On being informed that the goods are ready (for new clients); after the agreed deadline for the payment default, interest will be charged (for regular clients).

Any disputes shall be settled by the court of Milan.

### **Returns**

Before returning any goods, you need to request and obtain authorisation via email/fax from our sales office or our local representative to agree on how they will be returned. Goods sent on a carriage forward basis and/or without authorisation will be rejected. Repairs/replacements will not be processed for 30 days. Provide for an adequate stock or cold reserve when the dimmer performs essential functions in the system.

We do not provide replacements in advance.

In case of shipping or order errors, the product must be returned in its original packaging.

### **RCP insurance (civil liability on products)**

Relco S.r.l. products are marked and in many cases type approved IMQ, VDE, ENEC, etc. Please see internal pages for details on type-approval. Moreover, all Relco S.r.l. products are covered by a special RCP insurance policy with one of the top insurance companies, which is valid in any country worldwide.

***RELCO S.r.l. pursues a policy of continuous research and development and therefore reserves the right to change the characteristics of the products without prior warning. The information in this catalogue is only meant for informative purposes and is subject to constant changes, which means that it must not be considered as a commitment on behalf of Relco S.r.l.***

***Relco S.r.l. shall not be liable for any errors reported in this catalogue. No part of this publication can be reproduced, saved, filed or transmitted under any form and by any electronic, mechanical or any other kind of means without the prior permission in writing of Relco S.r.l.***